



Series 440



Molded PTFE Expansion Joints

PROCOTM

SERIES

440

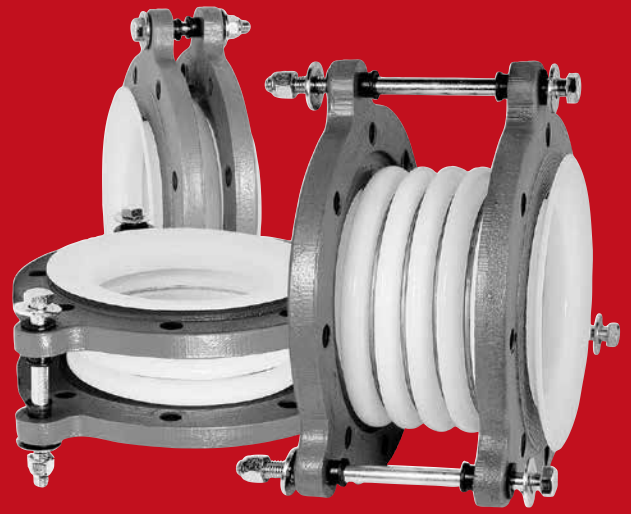

molded PTFE expansion joints

The PROCO Series 440 PTFE Molded Expansion Joints are used for corrosive applications found in: Chemical-Petrochemical, Industrial Process Piping Systems, Power Generation Plants, Pulp/Paper Plants, Water-Wastewater Sewage and Pollution Control Systems where metallic joints/lap joints or PTFE & FEP-lined rubber expansion joints may have been previously used or specified. Specify PROCO Series 440 expansion joints for installation between anchor points or next to mechanical equipment such as: Absorption Machines, Blowers, Chillers, Fans, Graphite Heat Exchangers, Glass Lined Vessels, Pumps, and Exotic Alloy/Plastic/Glass Lined Piping Systems. The Series 440 expansion joints are designed to: (1) Absorb Pipe Movements/Stress, (2) Reduce System Noise, (3) Reduce Mechanical Vibration, (4) Compensate Alignment/Offset, (5) Eliminate Electrolysis, (6) Protect against Start-up/Surge Forces. Our history in the manufacture of expansion joint products dates back to 1930. When an engineered solution is needed to solve a piping problem, call PROCO.

Engineered For Your Application. The PROCO Series 440 PTFE expansion joints are available in 2, 3, and 5 convolutions. Each convolution profile offers different overall lengths (face-to-face dimensions), movements and pressure/temperature rating to fit the required specification. Available styles include:

- **Style 442-BD:** Features two convolutions for minimal movements, higher pressure/temperature ratings and short face-to-face opening requirements. Style 442-BD sizes range from 1" to 24" diameter. (See Table 1)
- **Style 443-BD:** Features three convolutions and is designed for moderate movement and ease of system installation. Style 443-BD sizes range from 1" to 24" diameter. (See Table 2)
- **Style 445-BD:** Features five convolutions, and is designed for maximum movements, low pressure/temperature ranges, vibration reduction and greater face-to-face lengths. Style 445-BD sizes range from 1" to 20" diameter. (See Table 3)
- **Style 440-BE:** Features varying Neutral Lengths with Styles' 440-BD Limit Bolts. (See Table 4)

Absorbs Pipe-Wall and Fluid-Borne Noise. The quiet operating PROCO Series 440 PTFE expansion joints are a replacement for "sound transmitting" metallic/lap joints. Pipe Wall sound loses energy and is absorbed as the noise carried by the piping enters and exits the PTFE section. Fluid-borne noise is absorbed by the volumetric expansion (breathing of the connector). This action cushions water hammer and smoothes out pumping impulses.

Isolates Vibration and Motion. PROCO Series 440 PTFE expansion joints should be installed immediately after and ahead of equipment generating vibration in order to isolate the rotating/vibrating equipment from the rest of the piping system. For optimum performance, the PROCO Series 440 PTFE expansion joints should be installed horizontally to the shaft. Vertical and perpendicular installations are also acceptable as these expansion joints will accept axial, lateral and angular movements as well as vibration. Note: For maximum vibration transmission reduction, the pipe section beyond the PTFE expansion joints must be anchored or sufficiently rigid.

Reduces System Stress and Strain. Rigid attachment of piping to critical or mechanical equipment can produce excessive loading. Thermal or mechanically created strain-stress-shock are cushioned and absorbed with the installation of a flexible, low spring rate, PROCO Series 440 PTFE expansion joint. The PROCO Series 440 PTFE expansion joint adds a flexible component to the system that automatically self-corrects for misalignment created by structural movements caused by settling, pipe expansion or ground shifts.

Tested Force Pound and Spring Rate Tables. At PROCO we have machine tested nearly every size of the Series 440 PTFE expansion joints for Axial and Lateral Spring Rates and have provided Thrust/Force factors so designers can properly design system restraints. It should be noted that the PROCO Series 440 PTFE expansion joints are in accordance with the performance characteristics of the Fluid Sealing Association's Non-Metallic Expansion Joint Division.

Superior "Flex Life" and Strength. The PROCO Series 440 PTFE expansion joints are contour molded from extruded tubing providing superior "Flex Life" and Strength. Utilizing TEFLON® T-62 resins from DuPont, the PROCO Series 440 PTFE expansion joints provide dramatically more cycle life than that of PFA or FEP.

Flange and Limit Bolts. All PROCO Series 440 PTFE expansion joint flange configurations are coated with a rust inhibitive primer to prevent corrosion and are dimensionally tapped to ANSI 125/150# Standards. Hole drilling on center line, other drilling standards, or other flange materials, such as 316 stainless, 304 stainless, or Epoxy Coated flanges are available on special order. In addition, all PROCO Series 440 PTFE expansion joints are supplied with factory set limit bolts to prevent over-extension during operation.

Chemical Service Capability at Minimal Cost. Expensive, exotic metal, PTFE or FEP lined rubber expansion joints for severe chemical service can be replaced with the low cost PROCO Series 440 PTFE expansion joints. The PTFE bellows are van stoned to the flanges which allows all wetted surfaces to come in contact with only the PTFE material. Specify the PROCO Series 440 PTFE expansion joints where high temperatures coupled with lower pressures or lower temperatures coupled with higher pressures are proposed. The PROCO Series 440 PTFE offers the lowest cost expansion joint that is impervious to chemical attack. Use the PROCO "Chemical to Elastomer Guide" for reference on chemical compatibility.

Services and Locations. PROCO Series 440 PTFE Expansion Joints have been supplied and successfully used by a range of customers worldwide in the process industries for use in both organic and inorganic chemical processing and production, including such demanding applications as agrochemical and pharmaceutical chemical production, acid processing and food manufacture.

Information • Ordering • Pricing • Delivery. Day or night, weekends and holidays... the PROCO phones are monitored 24 hours around the clock. When you have a question, you can call us.

Toll-Free Phone	800 / 344-3246 USA/CANADA
International Calls	209 / 943-6088
Fax	209 / 943-0242
Email	sales@procoproducts.com
Website	www.procoproducts.com

Weekday office hours are 5:30 a.m. to 5:15 p.m. Pacific Time.

Protecting Piping And Equipment Systems From Stress/Motion

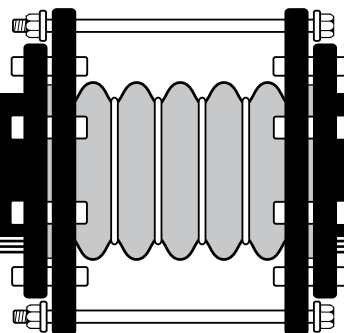

PROCO™

STYLE

440-BE



molded PTFE expansion joints

Table 4: Sizes • Movements • Spring Rates • Flange Standards • Temperatures • Vacuum • Weights

NOMINAL SIZE I.D.	NEUTRAL LENGTH INCHES	MOVEMENT CAPABILITIES ¹			SPRING RATE CAPABILITY ²			EXPANSION JOINT FLANGE DRILLING							PRESSURE AT TEMPERATURE (PSIG) @ °F								VACUUM RATING ³	WEIGHT / LBS			
		± AXIAL (Δx) MOVEMENT	LATERAL (Δy) DEFLECTION	ANGULAR DEFLECTION	COMPRESSION SPRING RATE	EXTENSION SPRING RATE	LATERAL SPRING RATE	THRUST FACTOR	# HOLES	THREADED HOLE SIZE	BOLT CIRCLE FLANGE "A"	PTFE FLARE O.D. "B"	FLANGE THICKNESS	NOMINAL FLANGE O.D.	LIMIT BOLT DIAMETER	BOLT CIRCLE LIMIT BOLT "C"	LIMIT BOLT "EAR" O.D.	70°	100°	150°	200°	250°			300°	350°	400°
		IN	IN	DEG.	LB _y /IN	LB _y /IN	LB _y /IN																				
Style 442-BE																											
1.00	1.750	0.344	.125	7	140	144	120	2.76	4	1/2-13	3.125	2.000	.438	4.250	.250	5.125	6.000	185	170	148	130	115	100	84	68	29.9° @ 425°F	2
1.50	1.813	0.344	.125	7	240	200	240	4.60	4	1/2-13	3.875	2.875	.469	5.000	.250	5.875	6.750	185	170	148	130	115	100	84	68	29.9° @ 425°F	2
2.00	1.875	0.344	.125	7	430	350	440	7.07	4	5/8-11	4.750	3.625	.484	6.000	.375	6.875	8.125	185	170	148	130	115	100	84	68	29.9° @ 425°F	7
3.00	2.188	0.406	.188	7	650	320	350	15.90	4	5/8-11	6.000	5.000	.578	7.500	.375	8.750	10.000	185	170	148	130	115	100	84	68	29.9° @ 425°F	10
4.00	2.281	0.438	.250	7	360	280	630	23.75	8	5/8-11	7.500	6.188	.578	9.000	.375	9.875	11.125	185	170	148	130	115	100	84	68	29.9° @ 400°F	18
6.00	2.531	0.469	.250	7	460	350	720	50.24	8	3/4-10	9.500	8.500	.641	11.000	.500	12.500	14.000	185	170	148	130	115	100	84	68	29.9° @ 400°F	29
8.00	2.750	0.531	.250	7	300	230	800	81.48	8	3/4-10	11.750	10.625	.688	13.500	.500	14.750	16.250	164	150	129	112	100	87	73	60	29.9° @ 250°F	47
10.00	2.969	0.563	.250	6	1280	870	1000	108.38	12	7/8-9	14.250	12.750	0.734	16.000	.500	17.500	19.000	164	150	129	112	100	87	73	60	29.9° @ 250°F	64
12.00	3.094	0.594	.250	5	380	240	1000	176.63	12	7/8-9	17.000	15.000	0.813	19.000	.625	20.500	22.000	70	59	48	40	35	30	26	22	29.9° @ 75°F	115
Style 443-BE																											
1.00	2.313	0.500	.250	14	130	130	260	2.81	4	1/2-13	3.125	2.000	.438	4.250	.250	5.125	6.000	138	126	107	90	76	64	53	45	29.9° @ 400°F	2
1.50	2.406	0.531	.250	12	80	70	110	5.09	4	1/2-13	3.875	2.875	.469	5.000	.250	5.875	6.750	138	126	107	90	76	64	53	45	29.9° @ 400°F	4
2.00	2.500	0.531	.375	12	70	80	160	9.11	4	5/8-11	4.750	3.625	.484	6.000	.375	6.875	8.125	138	126	107	90	76	64	53	45	29.9° @ 400°F	8
3.00	2.906	0.625	.500	10	140	160	190	16.91	4	5/8-11	6.000	5.000	.578	7.500	.375	8.750	10.000	138	126	107	90	76	64	53	45	29.9° @ 400°F	13
4.00	3.063	0.656	.500	10	220	160	190	25.40	8	5/8-11	7.500	6.188	.578	9.000	.375	9.875	11.125	138	126	107	90	76	64	53	45	29.9° @ 400°F	19
6.00	3.375	0.719	.563	9	350	190	540	50.24	8	3/4-10	9.500	8.500	.641	11.000	.500	12.500	14.000	138	126	107	90	76	64	53	45	29.9° @ 300°F	30
8.00	3.656	0.781	.563	9	450	170	750	81.48	8	3/4-10	11.750	10.625	.688	13.500	.500	14.750	16.250	120	110	94	80	67	57	47	38	29.9° @ 125°F	48
Style 445-BE																											
1.00	3.500	0.844	.500	20	50	110	50	2.81	4	1/2-13	3.125	2.000	.438	4.250	.250	5.125	6.000	72	61	46	40	34	29	27	24	NOT DESIGNED FOR VACUUM SERVICE	2
1.50	3.625	0.785	.500	20	75	80	50	5.09	4	1/2-13	3.875	2.875	.469	5.000	.250	5.875	6.750	72	61	46	40	34	29	27	24	NOT DESIGNED FOR VACUUM SERVICE	5
2.00	3.750	0.875	.500	15	60	50	50	9.11	4	5/8-11	4.750	3.625	.484	6.000	.375	6.875	8.125	72	61	46	40	34	29	27	24	NOT DESIGNED FOR VACUUM SERVICE	9
3.00	4.375	1.031	.500	17	55	60	170	16.91	4	5/8-11	6.000	5.000	.578	7.500	.375	8.750	10.000	72	61	46	40	34	29	27	24	NOT DESIGNED FOR VACUUM SERVICE	14
4.00	4.563	1.094	.625	15	70	60	80	25.40	8	5/8-11	7.500	6.188	.578	9.000	.375	9.875	11.125	72	61	46	40	34	29	27	24	NOT DESIGNED FOR VACUUM SERVICE	20
6.00	5.031	1.188	.625	15	190	130	195	50.24	8	3/4-10	9.500	8.500	.641	11.000	.500	12.500	14.000	72	61	46	40	34	29	27	24	NOT DESIGNED FOR VACUUM SERVICE	31

- NOTES: 1. Movements are non-concurrent and based from Neutral Length with Limit Bolts installed.
 2. Spring Rate Capability is based on 1" of movement at zero pressure conditions.
 3. Vacuum Rating is based from fully extended position. Style 445-BE is not designed for Vacuum Service.

PROCO STYLE NUMBER:	STYLE 440-BE MATERIALS OF CONSTRUCTION						
442-BE — 1" THROUGH 12"	BELLOWS	FLANGES	REINFORCING RINGS	LIMIT BOLTS	NUTS	GROMMETS	WASHERS
443-BE — 1" THROUGH 8"	PTFE T-62	DUCTILE IRON	STAINLESS STEEL	CARBON STEEL	CARBON STEEL	NEOPRENE	CARBON STEEL
445-BE — 1" THROUGH 6"							

PROCO™

STYLE

443-BD



molded PTFE expansion joints

Table 2: Sizes • Movements • Spring Rates • Flange Standards • Temperatures • Vacuum • Weights

NOMINAL SIZE I.D.	NEUTRAL LENGTH INCHES	MOVEMENT CAPABILITIES BASED ON THREE CONVOLUTION DESIGN ¹			SPRING RATE CAPABILITY ²				EXPANSION JOINT FLANGE DRILLING								PRESSURE AT TEMPERATURE (PSIG) @ °F								VACUUM RATING ³	WEIGHT / LBS	
		± AXIAL (Δx) MOVEMENT	LATERAL (Δy) DEFLECTION	ANGULAR DEFLECTION	COMPRESSION SPRING RATE	EXTENSION SPRING RATE	LATERAL SPRING RATE	THRUST FACTOR	# HOLES	THREADED HOLE SIZE	BOLT CIRCLE FLANGE "A"	PTFE FLARE O.D. "B"	FLANGE THICKNESS	NOMINAL FLANGE O.D.	LIMIT BOLT DIAMETER	BOLT CIRCLE LIMIT BOLT "C"	LIMIT BOLT "EAR" O.D.	70°	100°	150°	200°	250°	300°	350°			400°
		IN	IN	DEG.	LB _f /IN	LB _f /IN	LB _f /IN																				
1.00	1.750	0.500	.250	14	190	82	96	2.81	4	1/2-13	3.125	2.000	.313	4.250	.250	5.125	6.000	138	126	107	90	76	64	53	45	29.9" @ 400°F	2
1.25	1.810	0.500	.250	14	40	120	314	2.25	4	1/2-13	3.500	2.520	.394	4.630	.250	5.196	6.850	128	120	96	85	72	56	42	36	CF	5
1.50	2.000	0.500	.250	14	84	66	108	5.09	4	1/2-13	3.875	2.875	.344	5.000	.250	5.875	6.750	138	126	107	90	76	64	53	45	29.9" @ 400°F	4
2.00	2.750	0.750	.375	14	69	76	109	9.11	4	5/8-11	4.750	3.625	.438	6.000	.375	6.875	8.125	138	126	107	90	76	64	53	45	29.9" @ 400°F	8
2.50	3.188	0.750	.375	14	91	97	160	11.41	4	5/8-11	5.500	4.125	.500	7.000	.375	8.125	9.375	138	126	107	90	76	64	53	45	29.9" @ 400°F	11
3.00	3.625	1.000	.500	14	124	125	194	16.91	4	5/8-11	6.000	5.000	.500	7.500	.375	8.750	10.000	138	126	107	90	76	64	53	45	29.9" @ 400°F	13
4.00	3.625	1.000	.500	14	220	155	264	25.40	8	5/8-11	7.500	6.188	.625	9.000	.375	9.875	11.125	138	126	107	90	76	64	53	45	29.9" @ 400°F	19
5.00	4.000	1.000	.500	14	320	210	324	34.45	8	3/4-10	8.500	7.313	.750	10.000	.500	11.500	13.000	138	126	107	90	76	64	53	45	29.9" @ 300°F	25
6.00	4.000	1.125	.563	14	289	187	266	50.24	8	3/4-10	9.500	8.500	.750	11.000	.500	12.500	14.000	138	126	107	90	76	64	53	45	29.9" @ 300°F	30
8.00	6.000	1.125	.563	14	178	218	423	83.49	8	3/4-10	11.750	10.625	.938	13.500	.500	14.750	16.250	120	110	94	80	67	57	47	38	29.9" @ 125°F	48
10.00	7.000	1.188	.500	14	420	531	857	128.55	12	7/8-9	14.250	12.750	1.000	16.000	.500	17.500	19.000	82	70	64	52	46	39	34	30	19.0" @ 212°F	60
12.00	7.875	1.188	.625	14	743	542	857	144.72	12	7/8-9	17.000	15.000	1.000	19.000	.625	20.500	22.000	82	70	64	52	46	40	34	30	10.0" @ 212°F	77
14.00	8.500	1.250	.688	14	239	628	970	233.59	12	1-8	18.750	16.250	1.188	21.000	1.420	24.172	27.313	82	70	64	52	46	40	34	30	10.0" @ 212°F	132
16.00	9.188	1.375	.750	14	245	571	970	259.68	16	1-8	21.250	18.500	1.188	23.500	1.420	27.563	31.500	82	70	64	52	46	40	34	30	10.0" @ 212°F	165
18.00	11.063	1.188	.750	14	—	—	1085	321.90	16	1 1/8-8	22.750	21.000	1.188	25.000	1.420	29.000	32.906	60	58	48	42	36	30	28	26	9.0" @ 212°F	201
20.00	12.875	1.188	1.000	14	—	—	1142	374.57	20	1 1/8-8	25.000	23.000	1.188	27.500	1.420	31.500	35.438	60	58	48	42	36	30	28	26	6.0" @ 212°F	243
24.00	11.875	1.000	.750	14	—	—	—	538.36	20	1 1/4-7	29.500	27.250	1.344	32.000	1.420	35.906	39.844	60	58	48	42	36	30	28	26	4.0" @ 212°F	309

NOTES: 1. Movements are non-concurrent and based from Neutral Length with Limit Bolts installed.
 2. Spring Rate Capability is based on 1" of movement at zero pressure conditions.
 3. Vacuum Rating is based from fully extended position. CF = Contact Factory.

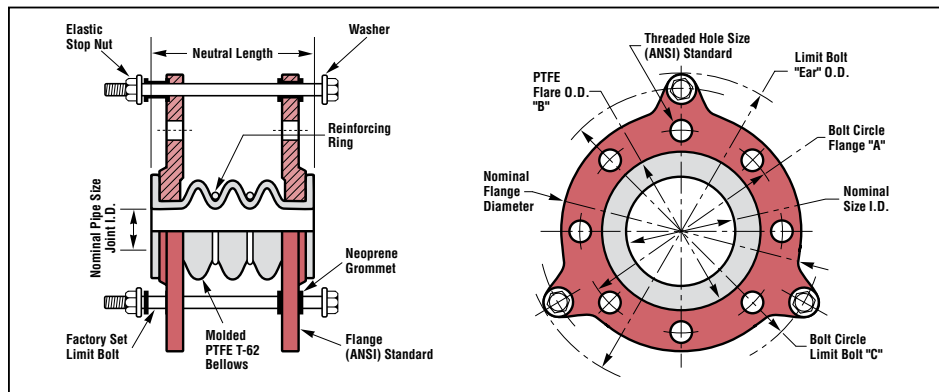

SERIES 443-BD MATERIALS OF CONSTRUCTION		
DESCRIPTION	1" THROUGH 12"	14" THROUGH 24"
BELLOWS	PTFE T-62	PTFE T-62
FLANGES	DUCTILE IRON	ZINC PLATED CARBON STEEL
REINFORCING RINGS	STAINLESS STEEL	STAINLESS STEEL
LIMIT BOLTS	CARBON STEEL	CARBON STEEL
NUTS	CARBON STEEL	CARBON STEEL
GROMMETS	NEOPRENE	NEOPRENE
WASHERS	CARBON STEEL	CARBON STEEL

PROCO™

STYLE

445-BD

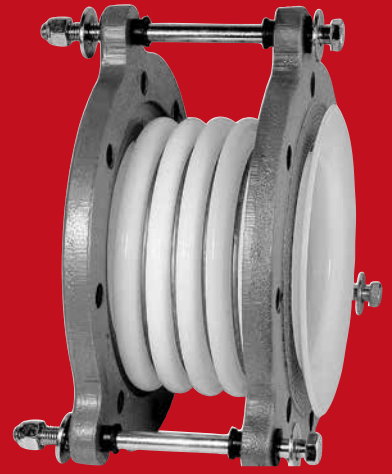

molded PTFE expansion joints

Table 3: Sizes • Movements • Spring Rates • Flange Standards • Temperatures • Vacuum • Weights

NOMINAL SIZE I.D.	NEUTRAL LENGTH INCHES	MOVEMENT CAPABILITIES BASED ON FIVE CONVOLUTION DESIGN ¹			SPRING RATE CAPABILITY ²				EXPANSION JOINT FLANGE DRILLING								PRESSURE AT TEMPERATURE (PSIG) @ °F								VACUUM RATING ³	WEIGHT / LBS		
		± AXIAL (ΔX) MOVEMENT	LATERAL (ΔY) DEFLECTION	ANGULAR DEFLECTION	COMPRESSION SPRING RATE	EXTENSION SPRING RATE	LATERAL SPRING RATE	THRUST FACTOR	# HOLES	THREADED HOLE SIZE	BOLT CIRCLE FLANGE "A"	PTFE FLARE O.D. "B"	FLANGE THICKNESS	NOMINAL FLANGE O.D.	LIMIT BOLT DIAMETER	BOLT CIRCLE LIMIT BOLT "C"	LIMIT BOLT "EAR" O.D.	70°	100°	150°	200°	250°	300°	350°			400°	Hg at Temp.
		IN	IN	DEG.	LB _f /IN	LB _f /IN	LB _f /IN																					
1.00	3.000	0.500	.500	20	30	44	22	2.81	4	1/2-13	3.125	2.000	.313	4.250	.250	5.125	6.000	72	61	46	40	34	29	27	24	NOT	2	
1.25	2.670	0.394	.470	20	36	114	171	2.25	4	1/2-13	3.500	2.520	.394	4.630	.250	5.196	6.850	62	56	42	36	30	26	22	22		5	
1.50	3.500	0.750	.500	20	75	83	46	5.09	4	1/2-13	3.875	2.875	.344	5.000	.250	5.875	6.750	72	61	46	40	34	29	27	24		5	
2.00	4.000	1.000	.500	20	60	47	50	9.11	4	5/8-11	4.750	3.625	.438	6.000	.375	6.875	8.125	72	61	46	40	34	29	27	24	DESIGNED	9	
2.50	4.600	0.980	.510	20	116	319	285	10.08	4	5/8-11	5.500	4.125	.500	7.000	.375	8.125	9.375	62	56	42	36	30	26	22	22		11	
3.00	5.000	1.000	.500	20	55	60	170	16.91	4	5/8-11	6.000	5.000	.500	7.500	.375	8.750	10.000	72	61	46	40	34	29	27	24		14	
4.00	5.250	1.250	.625	20	72	60	80	25.40	8	5/8-11	7.500	6.188	.625	9.000	.375	9.875	11.125	72	61	46	40	34	29	27	24	FOR	20	
5.00	6.000	1.250	.625	20	140	388	400	32.33	8	3/4-10	8.500	7.313	.750	10.000	.500	11.500	13.000	62	56	42	36	30	26	22	22		26	
6.00	6.000	1.250	.625	20	190	130	195	50.24	8	3/4-10	9.500	8.500	.750	11.000	.500	12.500	14.000	72	61	46	40	34	29	27	24		31	
8.00	8.000	1.250	.625	20	304	388	457	76.07	8	3/4-10	11.750	10.625	.938	13.500	.500	14.750	16.250	48	42	34	30	26	22	22	22	VACUUM	49	
10.00	8.750	1.250	.625	20	458	388	457	128.55	12	7/8-9	14.250	12.750	1.000	16.000	.500	17.500	19.000	48	42	34	30	26	22	22	22		64	
12.00	9.000	1.375	.688	20	529	445	457	144.72	12	7/8-9	17.000	15.000	1.000	19.000	.625	20.500	22.000	48	42	34	30	26	22	22	22		88	
14.00	12.790	1.375	.688	20	203	371	514	233.59	12	1-8	18.750	16.250	1.188	21.000	1.420	24.172	27.313	48	42	34	30	26	22	22	22	SERVICE	143	
16.00	13.500	1.625	1.000	20	180	383	514	259.68	16	1-8	21.250	18.500	1.188	23.500	1.420	27.563	31.500	48	42	34	30	26	22	22	22		179	
20.00	20.470	1.625	1.000	20	185	371	571	374.57	20	1 1/8-8	25.000	23.000	1.188	27.500	1.420	31.500	35.438	48	42	34	30	26	22	22	22		243	

NOTES: 1. Movements are non-concurrent and based from Neutral Length with Limit Bolts installed.
 2. Spring Rate Capability is based on 1" of movement at zero pressure conditions.
 3. Style 445-BD is not designed for Vacuum Service.

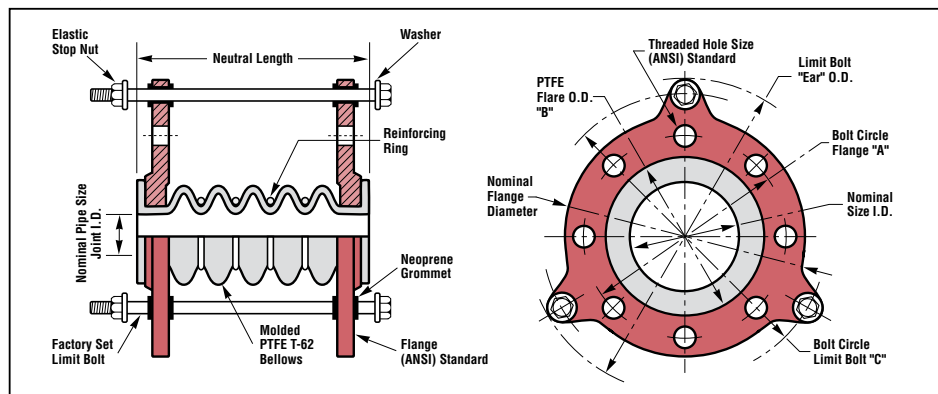

SERIES 445-BD MATERIALS OF CONSTRUCTION		
DESCRIPTION	1" THROUGH 12"	14" THROUGH 20"
BELLOWS	PTFE T-62	PTFE T-62
FLANGES	DUCTILE IRON	ZINC PLATED CARBON STEEL
REINFORCING RINGS	STAINLESS STEEL	STAINLESS STEEL
LIMIT BOLTS	CARBON STEEL	CARBON STEEL
NUTS	CARBON STEEL	CARBON STEEL
GROMMETS	NEOPRENE	NEOPRENE
WASHERS	CARBON STEEL	CARBON STEEL

Installation Instructions for Series 440 PTFE Expansion Joints

TORQUE TABLE LISTING

SIZE I.D. (IN)	1.0	1.25	1.5	2.0	2.5	3.0	4.0	5.0	6.0	8.0	10.0	12.0
TORQUE (FT/LBS)	10	16	25	52	47	82	54	80	100	135	125	155
TOLERANCE (+/-)(FT/LBS)	2	3	6	13	11	20	13	20	24	32	31	38

Notes: 1. Bolt Torque requirements may vary depending on mating flange material and installation.
2. "Over-Torque" may cause the PTFE material to creep.

1. Service Conditions: Make sure the expansion joint ratings for temperature, vacuum, spring rates and movements match the system requirements. Contact PROCO if the system requirements exceed those of the expansion joint selected.

2. Alignment: PROCO Series 440 PTFE expansion joints are not designed to make up for piping misalignment error. Pipe misalignment should be no more than 1/8" in any direction. Misalignment of an expansion joint will reduce the rated movements and can cause stress of material properties, thus causing reduced service life.

3. Limit Bolts: Limit bolts are factory set at the maximum allowable travel position to prevent over extension. Do not remove or alter nuts at any time. Damage or personal injury can result due to changes in limit bolt settings.

4. Anchoring: Solid anchoring is required whenever the pipeline changes direction. PROCO Series 440 PTFE expansion joints should be located as close as possible to these anchor points. If an anchoring system is not used, any associated pressure thrust can cause excessive movement, ultimately damaging the expansion joint. **(It should be noted that the attached limit bolts/cables are designed to limit movement and are not designed to handle pressure thrust.)**

5. Pipe Support: Piping must be supported by hangers or anchors so expansion joints do not carry any pipe weight.

6. Personnel Protection: It is strongly recommended that spray shields be used for all hazardous service to protect against serious personal injury in the event of expansion joint failure. (Contact PROCO for spray shield information.)

7. Installation:

a. Store expansion joints with wood covers in-place to protect PTFE flange surfaces from damage until ready to install.

b. Check to make sure PTFE surfaces are clean and free of foreign sediment. Remove nicks, burrs and deep scratches with a fine emery cloth. If surface irregularities cannot be completely removed, install a PTFE envelope-type gasket to obtain an adequate seal.

c. Install the PROCO Series 440 PTFE expansion joints to the prescribed neutral lengths. If expansion joints are used in high temperature processes, it is recommended that units be installed at/near the extended values. For cold process installations, expansion joints should be installed in a nearly compressed length. These settings will enable the expansion joint to realize full travel capabilities. (See appropriate Tables for Neutral Lengths.)

d. Thread installation bolts from mating flange side to prevent possible damage to PTFE elements. Extend bolts beyond the expansion joint flange by no more than 1-2 threads. Nuts are not necessary due to threaded flange holes.

e. Tighten flange bolts with a torque wrench. Tighten in an alternate crossing pattern in 20% increments until 80% of final bolt torques have been achieved. Tighten to final torque values (listed in Torque Table Listing) in a clockwise fashion around the flange to ensure bolts carry equal stress burdens.

f. Re-tighten bolts after first cycle of operation. Re-tighten as necessary after every planned maintenance shutdown. All bolts should be re-torqued to the above listed values.

8. Operations: After expansion joints are installed, it may be necessary to air blast the exterior to remove foreign debris, such as metal chips, from between the convolutions. The expansion joint should then be covered with a shield to protect from damage and foreign debris during operation. **(Note: Do not weld in immediate vicinity of expansion joint unless it is properly protected.)**

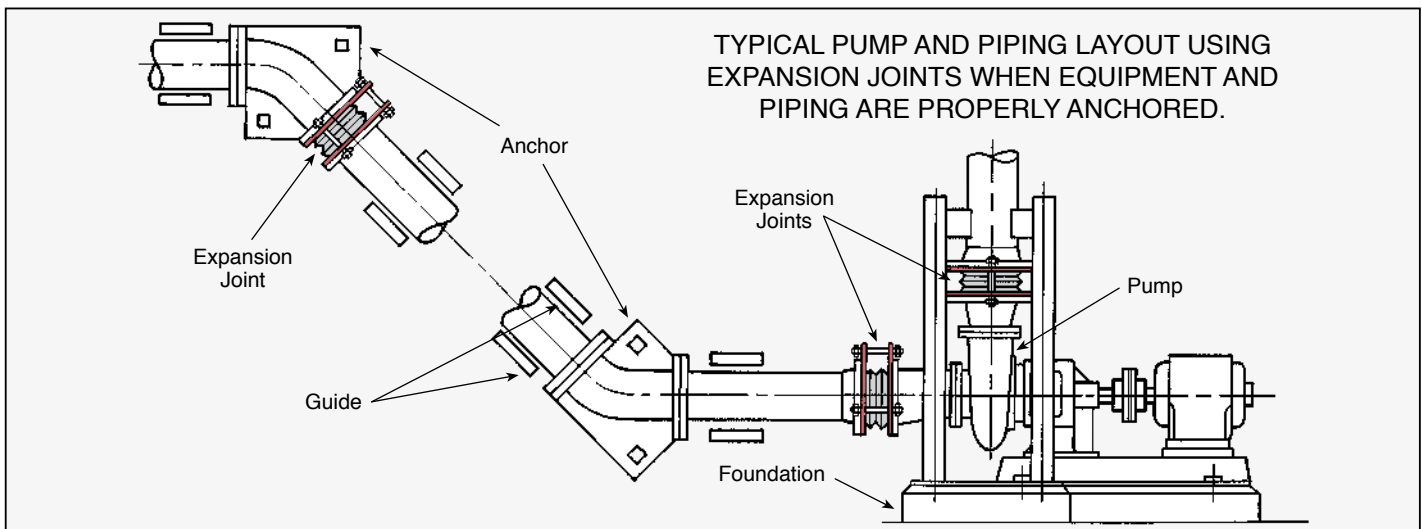

ENGINEERING DESIGN NOTES:

1. It is essential that piping system thrusts be calculated to ensure correct sizing of anchors and pipe supports, plus ensure that allowable thrust forces on adjacent mechanical and rotating equipment are not exceeded. Please use the following formulas:

$$T_p = P \cdot T_f$$

T_p is the pressure thrust (lb_f), P is the system operating pressure (Psig) and T_f is the thrust factor (or bellows effective area [in²]). The pressure thrust, T_p , will act in the axial direction and must be added to the axial spring force ($F_x \cdot \Delta x$) to give the total axial reaction force, R_x .

$$R_x = T_p + (F_x \cdot \Delta x)$$

R_x is the pipe support reaction force (lb_f), T_p is the pressure thrust (lb_f), F_x is the axial spring force of the unit and Δx is the expected or designed axial movement of the unit (See Tables 1-3).

2. It should be noted that axial spring rate values found in Tables 1 through 3 are based on an ambient temperature (70°F) and will decrease as the system temperature rises. In addition, spring rates decrease over time due to thermoplastic creep if units are operated under pressure.

We Cover The World!



PROCO PRODUCTS, INC. **The Expansion Joint People**

Demand the best — insist on PROCO!

- Knowledgeable sales staff that has an average of 20 years experience with expansion joints
- Daily UPS® pick-up
- Preselected freight carriers to minimize “interline transfer”
- Emergency service for nights, weekends, and even holidays
- Complete expansion joint product line
- Largest inventory in North America with warehouses in
Stockton, CA
Houston, TX
Atlanta, GA



DISTRIBUTED BY:

2431 North Wigwam Drive
Stockton, California 95205

Post Office Box 590
Stockton, California 95201-0590 USA

Toll Free: 800 . 344 . 3246 USA/Canada
International: 209 . 943 . 6088

Fax: 209 . 943 . 0242

E-mail: sales@procoproducts.com
Web Site: www.procoproducts.com

Warning: Expansion joints may operate in pipelines or equipment carrying fluids and/or gases at elevated temperatures and pressures. Normal precautions should be taken to make sure these parts are installed correctly and inspected regularly. Precautions should be taken to protect personnel in the event of leakage or splash. Note: Piping must be properly aligned and anchored to prevent damage to an expansion joint. Movement must not exceed specified ratings and control units are always recommended to prevent damage in the event other anchoring in the system fails. Properties applications shown throughout this data sheet are typical. This information does not constitute a warranty or representation and we assume no legal responsibility or obligation with respect thereto and the use to which such information may be put. Your specific application should not be undertaken without independent study and evaluation for suitability.