



Fabri-Valve 33 PTA / 33 PTD

Slurry Valves



ITT

ENGINEERED FOR LIFE

33 PTA / 33 PTD

ITT is a global leader with 65 years of design, manufacture and fabrication experience of engineered valves. ITT's leadership has resulted in vast experience with fluid handling, with precise expertise in specialized knife gate valves. Customers depend on ITT Engineered Valves to deliver reliable and cost effective solutions for the most demanding slurry applications.

While Keeping these applications in mind, ITT Engineered Valves developed the 33PTA and 33PTD push through knife gate valves to maximize service life and minimize downtime in the harshest slurry applications.



33 PTA
Heavy Duty Slurry



33 PTD
Light to Medium Duty Slurry

How the valves work:

The 33PTA and 33PTD slurry valves both work by axially compressing matching elastomer sleeves when the valve is open. It is the compression of the sleeves against each other that creates a pressure boundary that contains the media within the valve. When the valve is closed, the gate of the valve separates the matching sleeves and the compression of the sleeves against the gate that creates the pressure boundary that contains the media within the valve. While the gate of the valve is in a mid stroke position between open and closed, a small area of separation is created between the matching sleeves. This area of separation creates a self-flushing action that allows any solids that would interfere with sealing of the pressure boundary to be discharged away from the sleeves of the valve. The discharge media can be either discharged to the environment or captured by a splash guard to be directed to an area where it can be disposed of properly.

Open Position



Mid-stroke Position

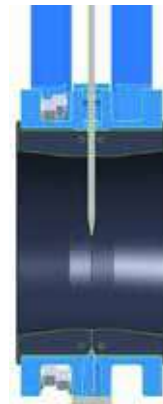

Closed Position

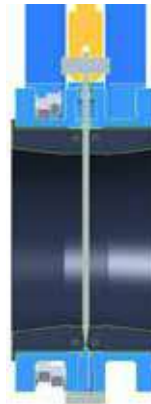

- Gate fully withdrawn from process flow
- Sleeves in contact with each other sealed by axial compression
- Pressure boundary is maintained between matching sleeves
- No obstructions or cavities for solids to collect
- Zero discharge in open position

- Gate is fully extended and separates matching sleeves
- Sleeves in contact with gate and sealed by axial compression
- Pressure boundary is maintained between gate and sleeves
- Zero discharge in closed position



33 PTA Heavy Duty Slurry Valve

- Engineered elastomer sleeves provide maximum performance throughout a wide range of abrasive and corrosive applications
- Able to be used in wet or dry applications with large particles
- Full port opening eliminates turbulence and minimizes pressure drop across valve
- Heavy duty sleeves are molded with an integral, fully encapsulated stiffener ring
- Full gate closure is assured by the lack of a cavity where solids can collect
- Integrated gate wiper extends gate and sleeve life and minimizes the possibility of discharge from the top of the valve
- No metal components are in contact with the process flow when in the open position
- Heavy duty sleeves are replaceable without valve disassembly
- 100% factory tested for 100% bi-directional bubble tight shut-off with zero downstream leakage
- No lubrication required

General Applications:

Mining	Alumina
Power	Chemical
Pulp and Paper	Cement, Sand, Aggregate

Materials of Construction:

Housing: Cast ductile iron
Gate: 316 stainless steel
Sleeves: Natural rubber (standard)
See page 5 for alternate sleeve materials

Temperature Rating:

Natural rubber sleeves = -50°F – 180°F
(-46°C – 82°C)
See page 4 for alternate sleeve materials

Pressure Ratings:

3" - 24" (DN 80-600): 100 psi (6.9 bar) CWP
26" - 36" (DN 650-900): 75 psi (5.2 bar) CWP
48" - 54" (DN 1200-1350): 50 psi (3.4 bar) CWP
60" (DN 1500): 30 psi (2.1 bar) CWP

Alternate gate materials allow higher pressure ratings. Consult factory for details.

33 PTA Features

Available Sleeve Materials:

Natural Rubber (standard):

This sleeve material has the highest resistance to abrasion and tearing, and it also has good resistance to heat. Maximum temperature 180°F (82°C).

EPDM:

This sleeve material has a wide variety of applications with superior resistance to solvents, acids, and alkalis as well as water and steam. Excellent resistance to higher temperatures. Great resistance to ozone and sunlight. Not recommended for use with oils, gasoline or other hydrocarbon based solvents or agents. Maximum temperature is 300°F (149°C).¹

NBR:

This sleeve material has excellent resistance to petroleum based oils, greases and other non oxidizing chemicals as well as hydrocarbon based agents. Poor resistance to ozone and oxygenated solvents. Maximum temperature is 250°F (121°C).¹

HNBR:

This sleeve material has excellent resistance to petroleum based oils, greases and other non oxidizing chemicals as well as hydrocarbon based agents. Poor resistance to ozone and oxygenated solvents. Maximum temperature is 280°F (138°C).¹

Chlorobutyl:

This sleeve material has good resistance to heat, oxygen, ozone and sunlight. Excellent resistance to alkalis and oxygenated solvents, water and steam. Poor resistance to hydrocarbon based agents. Maximum temperature is 230°F (110°C).¹

Neoprene:

This sleeve material is a general purpose sleeve material with resistance to mineral oils and greases. Fair resistance to abrasion. Maximum temperature is 180°F (82°C).¹

Note: All hazardous media and non-hazardous media above 180F must utilize safety precautions such as a splash guard to redirect the high temperature or hazardous discharge (see page 12 for details).

¹ Exposure to continuous elevated temperatures will result in premature aging of the elastomer.



Standard Configuration:

- Ductile iron housing
- 316SS gate
- Natural rubber sleeves
- Mild steel yoke
- Ductile iron handwheel
- Rubber coated retaining ring (8" and larger)

Options

- Alternate yoke materials
- Rod boots
- Handwheel stem covers
- Alternate actuation
 - Hand wheel
 - Bevel gear
 - Air cylinder
 - Hydraulic cylinder
 - Electric
 - Other
- Alternate wiper material
- Alternate sleeve configuration without load distribution rings (consult factory)
- Alternate sleeve material based on service conditions (media and temperature)
- Limit switches and positioners per customers' requirements

Features:

- Cast iron body housing
- Heavy duty yoke
- Lockout/tagout
- Full gate withdrawal
- Packingless design
- Heavy duty elastomer sleeves
- Unobstructed flow
- Blind flange capable
- Retainer rings to aid in installation

33 PTA Exploded View Parts List		
1	Body Housing	Ductile Iron
2	Gate	316 SS
3	Wiper Gland	Mild Steel
4	Wiper Material	Acrylic Silicone
5	Stem Assembly	304 SS
6	Yoke	Mild Steel
7	Handwheel	Ductile Iron
8	Stem Nut	Bronze
9	Sleeve Retainer Ring	Rubber/Mild Steel
10	Packing Gland Fasteners	Plated Steel
11	Gate Fasteners	304 SS
12	Yoke Fasteners	Plated Steel
13	Grease Fitting	Plated Steel
14	Body Spacer	Carbon Steel
15	Yoke Hub Fasteners	Plated Steel
16	Rod Boot	Nylon
17	Yoke Hub	Mild Steel
18	Sleeve	Rubber/Mild Steel
19	Stop Nut	Carbon Steel
20	Body Fasteners	Stainless Steel
21	Stem Cover	Mild Steel
22	Locking Pin	17-4 SS
23	Rod Boot Spacer Plate	Stainless Steel
24	Sleeve Retainer Fasteners	Plated Steel

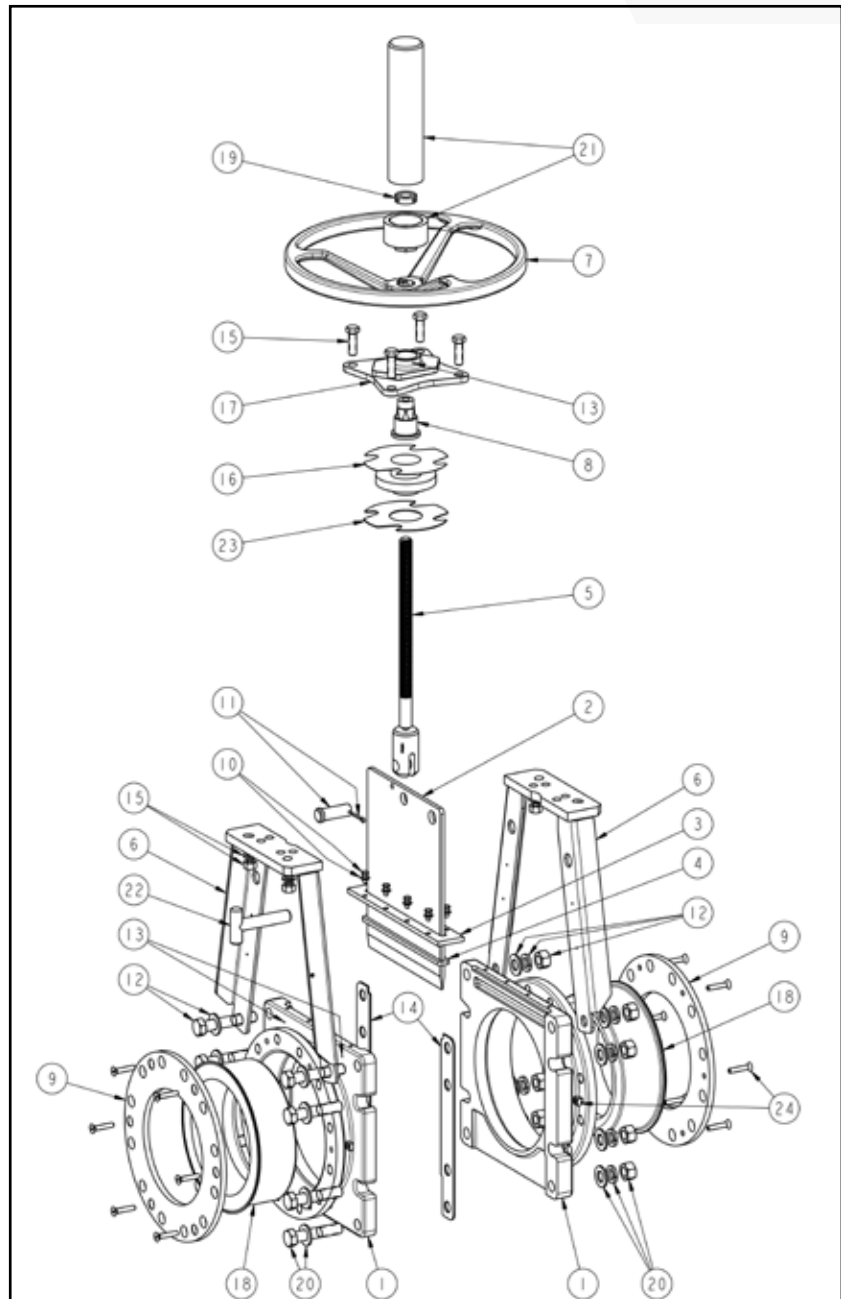

33 PTA Dimensions

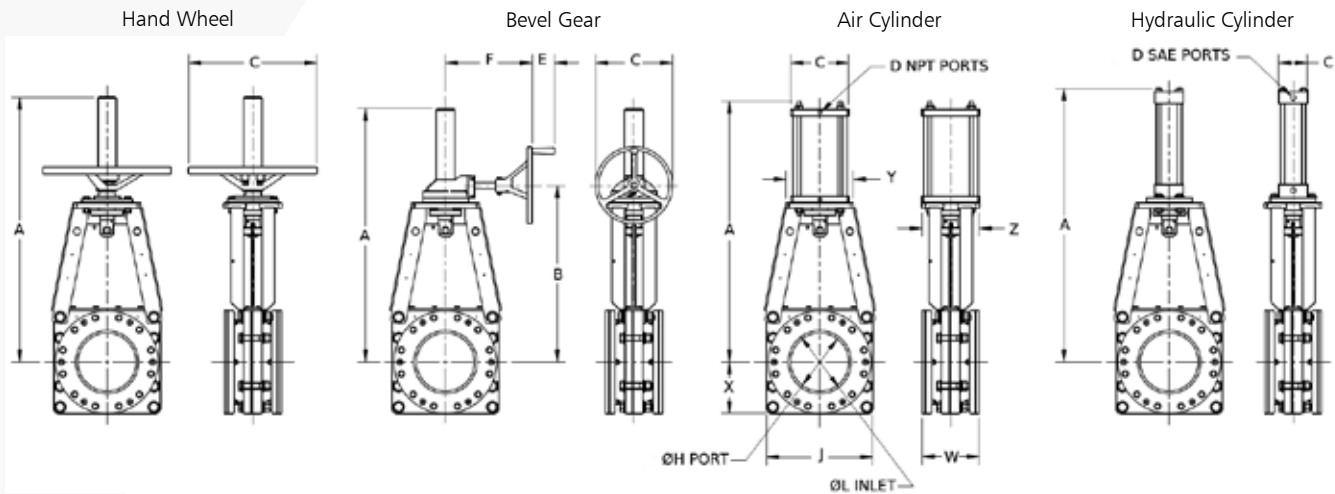

Dimensions (inches), Weight (lbs.)

Valve Size												Hand Wheel		
IN	DN	ØH	J	ØL	W*	W**	X	Y	Z	A	C	Weight		
3	75	2.41	8.88	2.81	6.88	5.88	4.44	8.00	7.62	23.28	16	83		
4	100	3.33	11.00	3.88	6.88	5.88	5.50	8.50	7.24	24.97	16	104		
6	150	5.38	13.00	5.81	7.00	6.00	6.50	8.50	8.01	28.35	16	119		
8	200	6.88	15.25	7.75	7.25	6.25	7.63	8.50	8.99	33.95	20	214		
10	250	9.06	16.56	9.81	8.88	7.88	8.28	10.50	8.99	41.26	20	293		
12	300	10.75	21.00	11.50	10.13	9.13	10.50	12.75	12.75	-	-	-		
14	350	12.50	22.75	13.25	10.13	9.13	11.38	12.75	12.72	-	-	-		
16	400	14.00	24.25	14.75	11.00	9.75	12.13	14.75	14.74	-	-	-		
18	450	14.88	26.50	16.75	12.25	10.75	13.25	14.75	14.74	-	-	-		
20	500	15.56	28.38	18.50	14.13	12.63	14.19	17.00	17.00	-	-	-		
24	600	21.19	33.80	23.00	14.63	13.13	16.90	19.00	18.99	-	-	-		
26	650	23.50	34.25	25.00	14.63	12.75	17.13	18.00	11.75	-	-	-		
30	750	26.75	38.75	29.00	15.56	13.69	19.38	23.50	14.25	-	-	-		
36	900	31.88	46.00	35.00	18.75	17.25	23.00	25.00	17.00	-	-	-		
42	1000													
48	1200													
54	1350													
60	1500													

Please Consult Factory for Details

Valve Size		Bevel Gear						Air Cylinder ¹					Hydraulic Cylinder ²					
IN	DN	A	B	C	E	F	Weight	Size	A	C	D	Weight	Size	A	C	D	Weight	
3	75	22.26	14.95	12	3.5	13.48	132	5	19.32	5.5	0.38"-18	75	2	21.07	3.0	8	77.2	
4	100	23.95	15.75	12	3.5	13.48	153	6	22.26	6.5	0.38"-18	101	2	23.50	3.0	8	98.5	
6	150	27.33	19.13	12	3.5	13.48	169	8	28.39	9.0	0.38"-18	145	2.5	29.76	3.5	8	124	
8	200	32.78	23.47	12	3.5	13.48	246	8	33.34	9.0	0.38"-18	236	2.5	34.34	3.5	8	200	
10	250	39.47	27.52	12	3.5	13.48	325	8	40.65	9.0	0.38"-18	322	3.25	42.65	4.5	12	314	
12	300	45.79	31.02	24	-	16.65	475	12	47.15	12.8	0.50"-14	502	4	48.53	5.0	12	446	
14	350	48.69	33.92	24	-	16.65	542	12	51.80	12.8	0.50"-14	571	4	53.18	5.0	12	562	
16	400	55.24	39.61	24	-	19.26	806	14	58.45	14.8	0.75"-14	1072	4	58.93	5.0	12	754	
18	450	61.98	41.73	24	-	19.26	956	14	61.88	14.8	0.75"-14	1225	5	63.14	6.5	12	972	
20	500	65.36	45.11	24	-	19.26	1187	16	67.58	17.0	0.75"-14	1463	5	68.52	6.5	12	1214	
24	600	77.95	53.32	24	-	19.26	1553	18	81.60	19.0	0.75"-14	1926	6	82.91	7.5	16	1694	
26	650	81.25	56	24	-	19	1650	-	-	-	-	-	4	86	5.0	12	1750	
30	750	94	65	24	-	19	2400	-	-	-	-	-	5	97	6.5	12	2500	
36	900	112	75	24	-	19	3800	-	-	-	-	-	6	114.25	7.5	12	3900	
42	1000																	
48	1200																	
54	1350																	
60	1500																	

Please Consult Factory for Details

1 Sized for 60 psi (4.1 bar) available air at cylinder. 2 Sized for 1500 psi (103.4 bar) available hydraulic pressure at cylinder.

33 PTA Dimensions

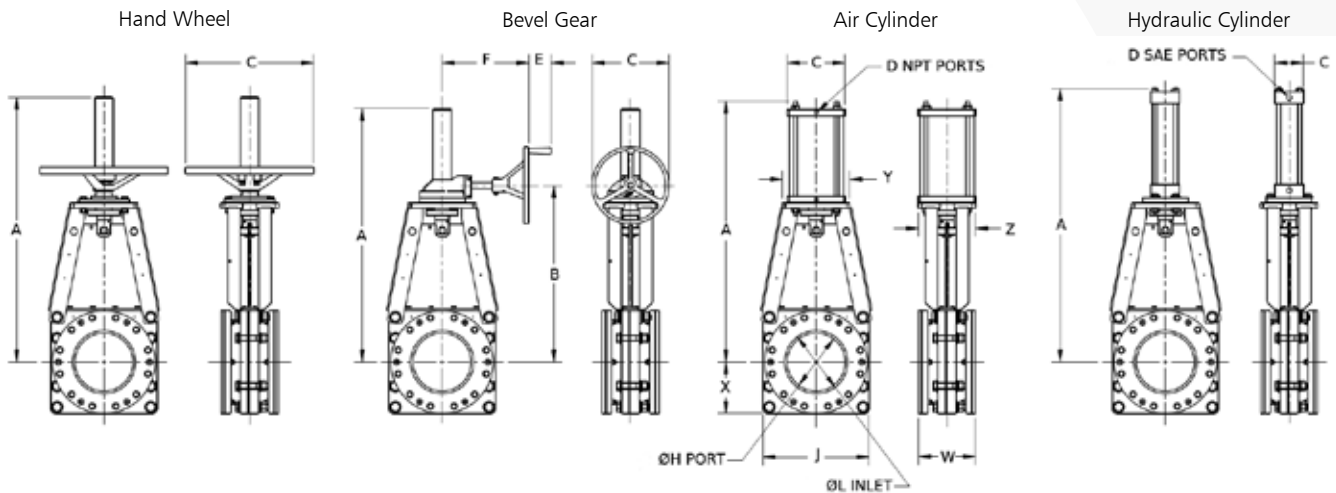

Dimensions (mm), Weight (kgs.)

Valve Size		Hand Wheel										Weight
DN	IN	ØH	J	ØL	W*	W**	X	Y	Z	A	C	
75	3	61	226	71	175	149	113	203	193	591	406	37.6
100	4	85	279	99	175	149	140	216	184	634	406	47.2
150	6	137	330	148	178	152	165	216	203	720	406	54.0
200	8	175	387	197	184	159	194	216	228	862	508	97.1
250	10	230	421	249	226	200	210	267	228	1048	508	133
300	12	273	533	292	257	232	267	324	324	-	-	-
350	14	318	578	337	257	232	289	324	323	-	-	-
400	16	356	616	375	279	248	308	375	374	-	-	-
450	18	378	673	425	311	273	337	375	374	-	-	-
500	20	395	721	470	359	321	360	432	432	-	-	-
600	24	538	859	584	372	334	429	483	482	-	-	-
650	26	596.9	869.95	635	371.6	323.85	435.1	457.2	298.45	-	-	-
750	30	679.45	984.25	736.6	395.22	347.73	492.13	596.9	361.95	-	-	-
900	36	809.75	1168.4	889	476.25	438.15	584.2	635	431.8	-	-	-
1000	42	Please Consult Factory for Details										-
1200	48											-
1350	54											-
1500	60											-

Valve Size		Bevel Gear							Air Cylinder					Hydraulic Cylinder				
DN	IN	A	B	C	E	F	Weight	Size	A	C	D	Weight	Size	A	C	D	Weight	
75	3	565	380	305	89	342	59.9	127	491	140	0.38"-18	33.8	50.8	535	76.2	8	35	
100	4	608	400	305	89	342	69.4	152.4	565	165	0.38"-18	45.8	50.8	597	76.2	8	45	
150	6	694	486	305	89	342	76.7	203.2	721	229	0.38"-18	65.8	63.5	756	88.9	8	56	
200	8	833	596	305	89	342	112	203.2	847	229	0.38"-18	107	63.5	872	88.9	8	91	
250	10	1003	699	305	89	342	147	203.2	1033	229	0.38"-18	146	82.55	1083	114	12	142	
300	12	1163	788	610	-	423	215	304.8	1198	325	0.50"-14	228	101.6	1233	127	12	202	
350	14	1237	862	610	-	423	246	304.8	1316	325	0.50"-14	259	101.6	1351	127	12	255	
400	16	1403	1006	610	-	489	366	355.6	1485	376	0.75"-14	486	101.6	1497	127	12	342	
450	18	1574	1060	610	-	489	434	355.6	1572	376	0.75"-14	556	127	1604	165	12	441	
500	20	1660	1146	610	-	489	538	406.8	1717	432	0.75"-14	664	127	1740	165	12	551	
600	24	1980	1354	610	-	489	704	457.2	2073	483	0.75"-14	874	152.4	2106	191	16	768	
650	26	2063.75	1422.4	609.6	-	482.6	748	-	-	-	-	-	101.6	2184.4	127	12	794	
750	30	2387.6	1651	609.6	-	482.6	1089	-	-	-	-	-	127	2463.8	165.1	12	1134	
900	36	2844.8	1905	609.6	-	482.6	1724	-	-	-	-	-	152.4	2901.95	190.5	12	1769	
1000	42	Please Consult Factory for Details																-
1200	48																	-
1350	54																	-
1500	60																	-

* Face to face including sleeve retainer rings. Add 1/4" to 1/2" for easy installation
 ** Face to face without sleeve retainer rings. Add 1/4" to 3/4" for easy installation

Note: Consult factory for alternate flange drilling patterns

33 PTD

33 PTD Light to Medium Duty Slurry Valve

- Engineered elastomer sleeves provide maximum performance throughout a wide range of abrasive and corrosive applications
- Full ported opening eliminates turbulence and minimizes pressure drop across valve
- Heavy duty sleeves are molded with an integral, fully encapsulated stiffener ring
- UHMWPE gate support liners guide the gate through the entire stroke, greatly reducing wear on the sleeves and gates
- Full gate closure is assured by the lack of a cavity where solids can collect
- Integrated gate wiper extends gate and sleeve life and minimizes the possibility of discharge from the top of the valve
- No metal components are in contact with the process flow when in the open position
- Heavy duty sleeves are replaceable without valve disassembly
- Open and closed lockout / tagout positions
- 100% factory tested for 100% bi-directional bubble tight shut-off with zero downstream leakage
- No lubrication required

Materials of Construction:

Housing: Mild steel

Gate: 316 Stainless Steel

Sleeves: Natural Rubber

See page 9 for alternate sleeve materials

Temperature Rating:

Natural Rubber sleeves = -50°F -180°F (-46°C - 82°C)

See page 9 for alternate sleeve materials

Pressure Ratings:

3" - 16" (DN 80 - 400): 150 (10.3 Bar)

CWP

18" - 24" (DN 450 - 600): 90 (6.2 Bar)

CWP

Alternate gate materials are available for higher pressure requirements of up to 1.5 times CWP of valve with standard gate material. Consult factory for details on actual higher pressure ratings.



33 PTD Features

Available Sleeve Materials:

Natural Rubber (standard):

This sleeve material has the highest resistance to abrasion and tearing, and it also has good resistance to heat. Maximum temperature 180°F (82°C).

EPDM:

This sleeve material has a wide variety of applications with superior resistance to solvents, acids, and alkalis as well as water and steam. Excellent resistance to higher temperatures. Great resistance to ozone and sunlight. Not recommended for use with oils, gasoline or other hydrocarbon based solvents or agents. Maximum temperature is 250°F (121°C).¹

Note: All hazardous media and non-hazardous media above 180F must utilize safety precautions such as a splash guard to redirect the high temperature or hazardous discharge (see page 12 for details).

¹Exposure to continuous elevated temperatures will result in premature aging of the elastomer.

Standard Configuration:

- Mild steel housing
- 316SS gate
- Natural rubber sleeves with integral retainer ring
- Mild steel yoke
- Ductile iron handwheel

Options

- Alternate flange drilling
- Rod boots
- Handwheel stem covers
- Alternate body materials
- Alternate yoke materials
- Alternate actuation
 - Hand wheel
 - Bevel gear
 - Air cylinder
 - Hydraulic cylinder
 - Electric
 - Other
- Alternate wiper material
- Alternate sleeve material based on service conditions (media and temperature)
- Limit switches and positioners per customers' requirements

Features:

- Steel body housing
- Heavy duty yoke
- Lockout/tagout
- Full gate withdrawal
- Packingless design
- Heavy duty elastomer sleeves
- Unobstructed flow
- Blind flange capable



33 PTD

33 PTD Exploded View Parts List		
1	Body Housing	Mild Steel
2	Gate	316 SS
3	Wiper Gland	Mild Steel
4	Wiper Material	Acrylic Silicone
5	Stem Assembly	304 SS
6	Yoke	Mild Steel
7	Handwheel	Ductile Iron
8	Stem Nut	Bronze
9	Gate Support Liner	UHMWPE
10	Packing Gland Fasteners	Plated Steel
11	Gate Fasteners	Plated Steel
12	Yoke Fasteners	Plated Steel
13	Grease Fitting	Plated Steel
14	Body Spacer	Mild Steel
15	Yoke Hub Fasteners	Plated Steel
16	Rod Boot	Nylon
17	Yoke Hub	Mild Steel
18	Sleeve with Retainer Ring	Rubber/Mild Steel
19	Stop Nut	Carbon Steel
20	Body Fasteners	Stainless Steel
21	Stem Cover	Mild Steel
22	Lock Pin	17-4 SS
23	Rod Boot Support Plate	Stainless Steel

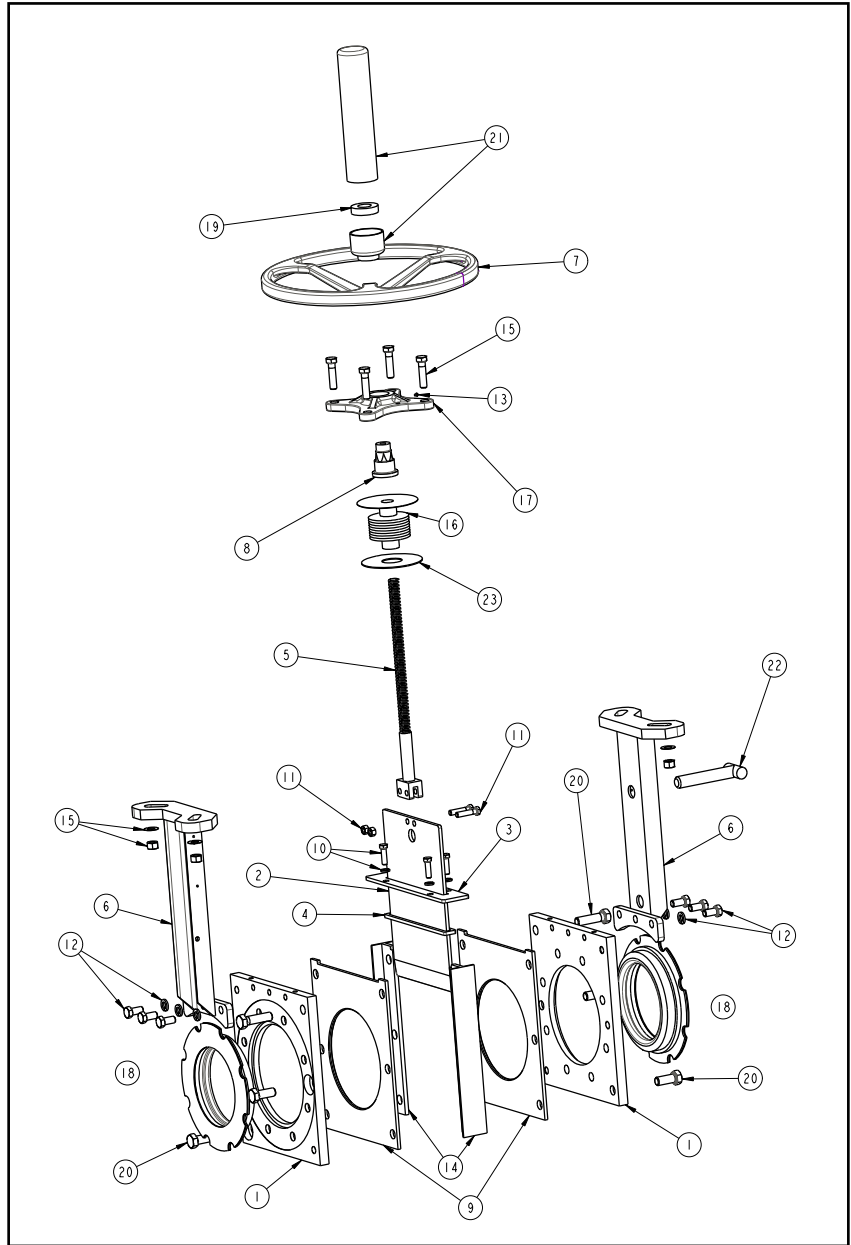

33 PTD Dimensions

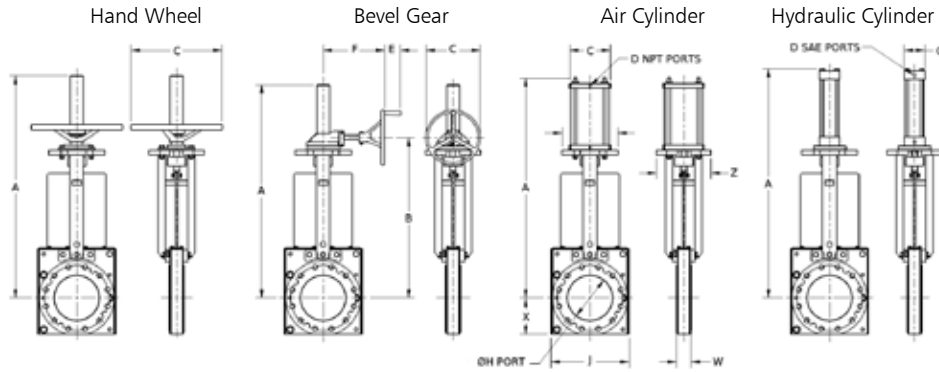

Dimensions (inches), Weight (lbs.)

Valve Size		Hand Wheel							Bevel Gear						Hydraulic Cylinder					
IN	DN	ØH	J	W	X	Y	Z	A	C	Weight	A	B	C	E	F	Weight	A	C	D	
2	50	Consult Factory							-	-	-	-	-	-	-	-	-	Consult Factory		
3	80	3.00	8.00	2.50	4.25	6.50	6.50	24.81	16.00	90	-	-	-	-	-	-	-	-	-	
4	100	4.00	9.50	2.50	4.50	6.50	6.50	27.56	16.00	100	-	-	-	-	-	-	-	-	-	
6	150	6.00	11.75	2.75	6.00	9.00	8.88	33.94	16.00	130	-	-	-	-	-	-	-	-	-	
8	200	8.00	14.38	3.25	6.50	11.00	10.88	42.44	20.00	210	-	-	-	-	-	-	-	-	-	
10	250	10.00	17.13	3.25	8.19	12.25	12.00	50.59	20.00	280	-	-	-	-	-	-	-	-	-	
12	300	12.00	19.63	3.50	10.00	12.25	12.25	-	-	-	57.88	40.81	12.00	3.50	13.59	164	-	-	-	
14	350	13.25	21.63	3.63	11.00	14.50	14.50	-	-	-	63.39	44.31	12.00	3.50	13.59	218	-	-	-	
16	400	15.25	24.00	4.19	13.00	16.50	16.63	-	-	-	65.88	48.88	12.00	3.50	16.25	323	-	-	-	
18	450	17.25	25.75	4.19	13.75	16.50	16.63	-	-	-	70.25	51.44	18.00	6.50	17.00	345	-	-	-	
20	500	19.25	28.00	5.19	15.50	18.00	19.00	-	-	-	80.63	59.31	18.00	6.50	17.00	504	-	-	-	
24	600	23.25	32.75	5.19	21.4	18.00	19.00	-	-	-	100.63	72.56	24.00	6.50	18.25	590	-	-	-	

Valve Size		Air Cylinder															
IN	DN	Cyl Size	A	C	D	Cyl Size	A	C	D	Cyl Size	A	C	D	Cyl Size	A	C	D
2	50	Consult Factory															
3	80	5"	24.50	5.50	3/8"-18	6"	24.75	6.50	3/8"-18	-	-	-	-	-	-	-	-
4	100	5"	27.56	5.50	3/8"-18	6"	27.25	6.50	3/8"-18	-	-	-	-	-	-	-	-
6	150	6"	33.88	6.50	3/8"-18	8"	34.25	9.00	3/8"-18	-	-	-	-	-	-	-	-
8	200	8"	42.25	9.00	3/8"-18	10"	43.75	11.00	1/2"-14	-	-	-	-	-	-	-	-
10	250	8"	50.75	9.00	3/8"-18	10"	52.25	11.00	1/2"-14	12"	52.75	12.75	1/2"-14	-	-	-	-
12	300	8"	57.63	9.00	3/8"-18	10"	59.18	11.00	1/2"-14	12"	59.63	12.75	1/2"-14	-	-	-	-
14	350	10"	64.63	11.00	1/2"-14	12"	65.13	12.75	1/2"-14	14"	65.00	14.75	3/4"-14	-	-	-	-
16	400	10"	70.69	11.00	1/2"-14	12"	71.19	12.75	3/4"-14	14"	71.06	14.75	3/4"-14	16"	71.38	17.0	3/4"-14
18	450	10"	75.06	11.00	1/2"-14	12"	75.56	12.75	3/4"-14	14"	75.44	14.75	3/4"-14	16"	75.75	17.0	3/4"-14
20	500	12"	85.94	12.75	1/2"-14	14"	85.81	14.75	3/4"-14	16"	86.13	17.00	3/4"-14	18"	87.13	19.0	3/4"-14
24	600	12"	105.9	12.75	1/2"-14	14"	105.8	14.75	3/4"-14	16"	106.13	17.00	3/4"-14	18"	107.13	19.0	3/4"-14

Dimensions (mm), Weight (kgs.)

Valve Size		Hand Wheel							Bevel Gear						Hydraulic Cylinder				
DN	IN	ØH	J	W	X	Y	Z	A	C	Weight	A	B	C	E	F	Weight	A	C	D
50	2	Consult Factory							-	-	-	-	-	-	-	-	Consult Factory		
80	3	76	203	64	108	165	165	630	406	40.8	-	-	-	-	-	-	-	-	-
100	4	102	241	64	114	165	165	700	406	45.4	-	-	-	-	-	-	-	-	-
150	6	152	298	70	152	229	226	862	406	59.0	-	-	-	-	-	-	-	-	-
200	8	203	365	83	165	279	276	1078	508	95.3	-	-	-	-	-	-	-	-	-
250	10	254	435	83	208	311	305	1285	508	127	-	-	-	-	-	-	-	-	-
300	12	305	499	89	254	311	311	-	-	-	1470	1037	305	89	345	74.4	-	-	-
350	14	337	549	92	279	368	368	-	-	-	1610	1125	305	89	345	98.9	-	-	-
400	16	387	610	106	330	419	422	-	-	-	1673	1242	305	89	413	147	-	-	-
450	18	438	654	106	349	419	422	-	-	-	1784	1307	457	165	432	156	-	-	-
500	20	489	711	132	394	457	483	-	-	-	2048	1506	457	165	432	229	-	-	-
600	24	591	832	132	543	457	483	-	-	-	2556	1843	610	165	464	268	-	-	-

Valve Size		Air Cylinder															
IN	DN	Cyl Size	A	C	D	Cyl Size	A	C	D	Cyl Size	A	C	D	Cyl Size	A	C	D
50	2	Consult Factory															
80	3	127mm	622	140	3/8"-17	152mm	629	165	3/8"-17	-	-	-	-	-	-	-	-
100	4	127mm	700	140	3/8"-18	152mm	692	165	3/8"-18	-	-	-	-	-	-	-	-
150	6	152mm	861	165	3/8"-18	203mm	870	229	3/8"-18	-	-	-	-	-	-	-	-
200	8	203mm	1073	229	3/8"-18	254mm	1111	279	1/2"-14	-	-	-	-	-	-	-	-
250	10	203mm	1289	229	3/8"-18	254mm	1327	279	1/2"-14	305mm	1340	324	1/2"-14	-	-	-	-
300	12	203mm	1464	229	3/8"-18	254mm	1503	279	1/2"-14	305mm	1515	324	1/2"-14	-	-	-	-
350	14	254mm	1642	279	1/2"-14	305mm	1654	324	1/2"-14	356mm	1651	375	3/4"-14	-	-	-	-
400	16	254mm	1796	279	1/2"-14	305mm	1808	324	3/4"-14	356mm	1805	375	3/4"-14	406mm	1813	432	3/4"-14
450	18	254mm	1907	279	1/2"-14	305mm	1919	324	3/4"-14	356mm	1916	375	3/4"-14	406mm	1924	432	3/4"-14
500	20	305mm	2183	324	1/2"-14	356mm	2180	375	3/4"-14	406mm	2188	432	3/4"-14	457mm	2213	483	3/4"-14
600	24	305mm	2691	324	1/2"-14	356mm	2688	375	3/4"-14	406mm	2696	432	3/4"-14	457mm	2721	483	3/4"-14

Safety is Our Concern

ITT Engineered Valves is a global leader with 65 years of design, manufacture and fabrication experience of engineered valves. ITT's leadership has resulted in vast experience with fluid handling, with precise expertise in specialized knife gate valves. This experience is a direct result of our core values of respect, responsibility and integrity which encapsulate our product designs and ethics.

Safety is a responsibility that we have to our customers, employees, business partners and the communities where we operate. By design, 33PTA and 33PTD valves self flushing by allowing small amounts of media to be discharged from the bottom of the valve while they are in a mid-stroke position. If discharged media is hazardous to personnel or the environment, it is recommended that precautions be in place to prevent injury to personnel or harm to the environment. For this reason, ITT Engineered Valves requires the use of a splash guard for push through valves that are used applications where the temperature of the media is greater than 180°F.

Use of a splash guard allows any hazardous discharged media to be contained or redirected to an area where it is able to be treated or collected for proper re-use or disposal.

Safety and "Push Through" valves...

"Push Through" valves are designed to be "self flushing"

- Small amount of media flow across the sealing surfaces while the valve is in a mid-stroke position
- The flushing media exits the valve from the bottom of the valve everytime the valve is cycled open or closed
- This "self flushing" feature eliminates the need for additional flush piping or routine cleaning of the valve to remove solids build-up or seat fouling
- Splash guards mount to the bottom of the valve and have threaded ports to allow the user to re-direct any hazardous flushing media to a safe area

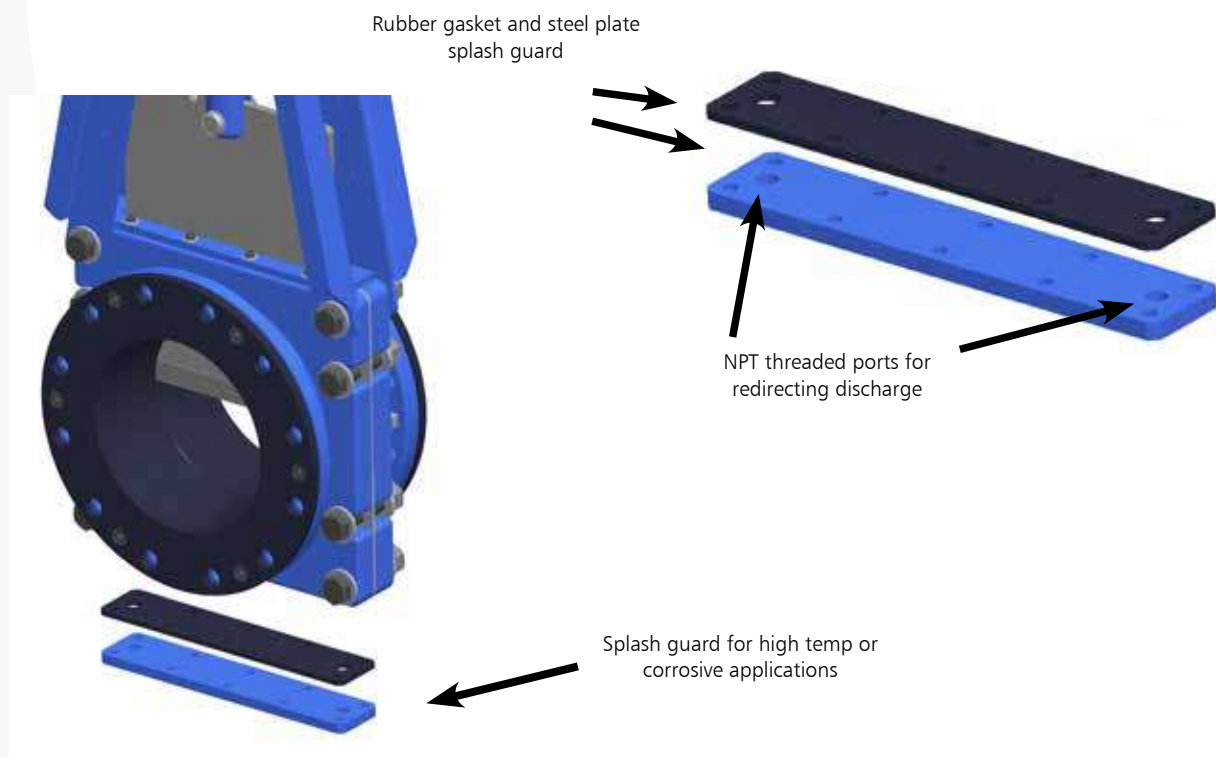

Available Sleeve Materials

Natural Rubber:

Advantages:

- Fatigue and tear resistance
- Dynamic loading
- High tensile strength and resistant to elongation
- Good flexibility in cold weather (-50°F)

Disadvantages:

- Poor resistance to grease/oil, ozone, acids & hydrocarbon fuels
- Continuous operation temperature <180°F

EPDM:

Advantages:

- Low friction coefficient
- Good outdoor weathering resistance
- Sustain high continuous operating temperature
- Excellent anti-hydrolyzing (water & steam) resistance

Disadvantages:

- Poor resistance to hydrocarbon fuels & greases
- Low resistance to most of mineral-oil-based-fluids

Neoprene:

Advantages:

- Resistance to mineral oils and greases

Disadvantages:

- Reduced resistance to abrasion compared to natural rubber

NBR:

Advantages:

- Resistant to hydrocarbon based solvents
- Good resistance to alkalis, gasoline, oil and acids

Disadvantages:

- Poor resistance to ozone and oxygenated solvents
- Low resistance to most of mineral-oil-based-fluids

HNBR:

Advantages:

- Resistant to hydrocarbon based solvents
- Good resistance to alkalis, gasoline, oil and acids

Disadvantages:

- Poor resistance to ozone and oxygenated solvents
- Low resistance to most of mineral-oil-based-fluids

Chlorobutyl:

Advantages:

- Heat, oxygen, ozone and sunlight resistance
- Resistance to alkalis, oxygenated solvents

Disadvantages:

- Poor resistance to hydrocarbon based on agents



33PTA sleeve with separate retaining ring



Slurry Valve Selection

In addition to the 33PTA and 33PTD slurry valves, ITT offers other valves that are well suited for slurry service. Particle size, slurry concentration, pressure, temperature and line size are considerations when selecting the proper valve for your service. The following guidelines will aid in the selection of the most common valve appropriate for the specific application. Please contact your local sales representative or the factory for special considerations or alternate configurations that may be suited for your service conditions.



Smaller Particles, Low Solids

- Presence of solids is primarily by accident
- Solids size smaller than 100 mesh (less than 0.006 inches or 149 microns)
- Non-settling slurry
- The slurry specific gravity < 1.05
- Less than 10% solids by weight

[Fabri-Valve 33PTD](#)

Additional Valve Options

[Fabri-Valve C67 with Chest Liners](#)

[Fabri-Valve XS150-ULV](#)

[Fabri-Valve CF33/133](#)

Smaller Particles, High Solids

- Solids size smaller than 100 mesh (less than 0.006 inches or 149 microns)
- Up to 30% solids by weight

[Fabri-Valve 33PTD](#)

Additional Valve Options

[Fabri-Valve XS150-ULV](#)

[Fabri-Valve CF33/133](#)

Medium Particles

- Solids size from 100 to 6 mesh (0.006-0.132 inches or 149-3353 microns)
- Settling or non settling slurry
- The slurry specific gravity < 1.2
- 10-30% solids by weight

[Fabri-Valve 33PTA or 33PTD](#)

Additional Valve Options

[Fabri-Valve CF33/133](#)

Must have flush bonnet or splash guard

Larger Particles

- Slurry's main purpose is to transport material
- Solids size 6 to 4 mesh (0.132-.0185 inches or 3353-4760 microns)
- Settling or non-settling slurry
- The slurry specific gravity > 1.2
- Greater than 30% solids by weight

[Fabri-Valve 33PTA or 33PTD](#)

Additional Valve Options

[Fabri-Valve CF33/133](#)

Must have flush bonnet or splash guard



Valve Guide by Slurry Type

This guide is intended to be used as a general guide to slurry valve applications. Refer to the factory for specific recommendations based on actual service conditions.

Product	Max. Dia (In.)	Discharge	Pressure Limit (PSI)	Temperature Limit (°F)	Dirty Water	Low Concentration < 10% Solids			Medium Concentration 10-30% solids			High Concentration > 30% solids		
					Small Particulate	Small Particulate	Medium Particulate	Large Particulate	Small Particulate	Medium Particulate	Large Particulate	Small Particulate	Medium Particulate	Large Particulate
C/F 133	54	Zero ¹	150 ²	200 ³										
C/F 33	54	High	150 ²	200 ³										
33PTA	36	Low	100 ²	180 ⁴										
33PTD	24	Low	90/150 ⁵	180 ⁴										
67 w/ Chest Liners	24	Zero	150	350										
	30		100											
	36		80											
XS150-ULV	24	Zero	150	170 ³										
XS150	24	Zero	285	280 ³										
45 RP	24	Zero	150	170 ³										
Dia-Flo Straightway	12	Zero	100	225										
Dia-Flo Weir	12	Zero	200	350										
Cam-Tite	6	Zero	1500 ⁶	750 ⁶										

- Best
- Acceptable
- Not Recommended

Particle Size	Small	Medium	Large*
microns	<149	149-3353	3353-4760
inches	<0.006	0.006-0.132	0.132-0.185
mesh size	>100	100-6	6-4

*Consult factory for larger particle sizes

- 1 Flushing or draining the bonnet is required.
- 2 Higher pressure options are available
- 3 Higher temperature options are available
- 4 Valve Temperature Rating = 180° F (Non hazardous line media). Hazardous/Non-Hazardous media above 180°F must utilize safety precautions such as a splash guard to redirect the high temperature discharge
 - 33 PTA EPDM sleeves = -20–300°F (-29–149°C)
 - 33 PTD EPDM = -20–300°F (-29–149°C)
 - Natural Rubber sleeves = -50–180°F (-46–82°C)
- 5 150 CWP (10.3 Bar): 3" - 16" (DN 80 - 400) and 90 CWP (6.2 Bar): 18" - 24" (DN 450 - 600)
- 6 Dependent on material selected and size

Customer is responsible to protect personnel and the environment from hazardous discharge.

Visit our website at

www.engvalves.com

ITT Engineered Valves

ITT Engineered Valves offers not only a broad range of specialty knife gate valves but also is an industry leading manufacturer of diaphragm and ball valves for corrosive and erosive services across many industries.



Fabri-Valve
C45



Dia-Flo
Diaphragm valve



Cam-Tite
ball valve



Fabri-Valve
XS150-ULV



Fabri-Valve
C/F 33/133



Fabri-Valve
C67

ITT Industrial Process Global Mining Capabilities

ITT Goulds dominance in the mining industry dates back to the latter 1800s. Designed for the most severe applications, our pumps can be found in coal, aluminum, copper, iron, clay, phosphate, potash, soda ash, salt, gold and aggregate industries throughout the world.

ITT offers the widest range of corrosion and abrasion resistant slurry pumps in the industry, including vertical, horizontal, and submersible designs for cyclone feed, tailings disposal, minerals processing, mine dewatering, clarifier underflow, and sump services. For more information visit: www.gouldspumps.com/market_MiningandMinerals.html

For more information contact:

Engineered Valves

1110 Bankhead Avenue
Amory, MS 38821 USA
tel (800) 541-1849
(662) 256-7185
fax 662-256-7932
www.engvalves.com
engvalves.custserv@itt.com

ITT Brazil

Estrada Velha Itu-Salto km 40.4
Salto, São Paulo 13324-195
tel 55-11 4602 9200
fax 55-11 4602 9215

ITT China

32F Tower A, Hongqiao City Center
of Shanghai, 100 Zunyi Rd,
Shanghai 200051, China
tel 86-21 2231-2222
fax 86-21 2231-2200

Engineered Valves

33 Centerville Road
Lancaster, PA 17603
tel 717-509-2200
fax 1-800-231-0330



ENGINEERED FOR LIFE

Engineered Valves, LLC

1110 Bankhead Ave
Amory, MS 38821
Tel: +1 (662) 256-7185
www.engvalves.com