

Fabri-Valve®

C132 Transmitter  
Isolation Valve

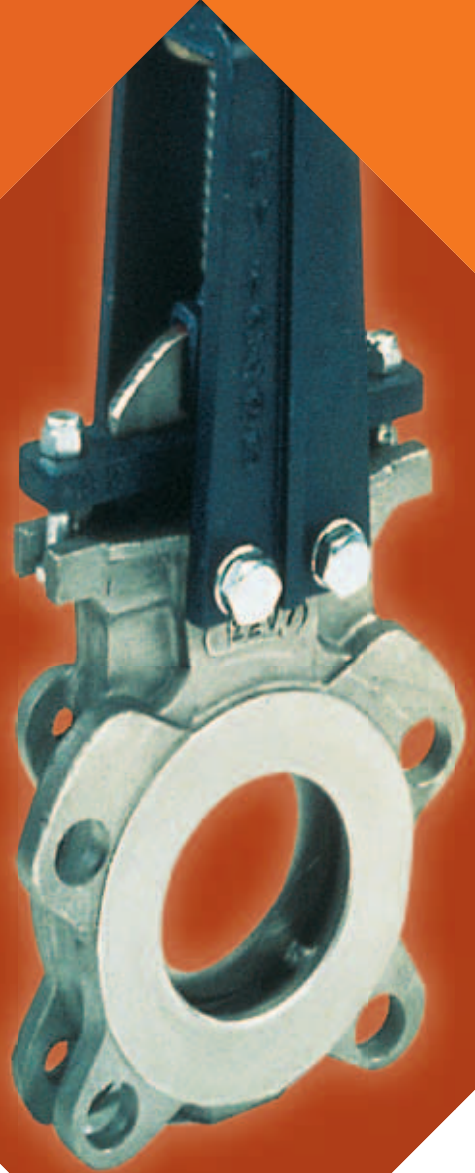

**ITT**

ENGINEERED FOR LIFE

# C132 Transmitter Isolation Valve

The Fabri-Valve Figure C132 transmitter isolation valve is designed specifically to isolate an instrument transmitter from a tank. This allows transmitter replacement or maintenance of the transmitter without disrupting the process or draining the vessel. A special tank side flange permits blind boltup from the tank exterior. This is accomplished by moving the upper flange holes outboard. They remain on the ANSI 125/150 bolt circle but are now located closer to the horizontal centerline. Fabri-Valve transmitter isolation valves are designed to fit installations where the upper tank flange bolts are located 25° to 27° above the horizontal centerline. The transmitter side flange bolting is a standard ANSI 125/150 configuration. The Fabri-Valve transmitter isolation valve is available in two configurations; the C132R features the Fabri-Valve solid cast stainless steel body with heavy duty cast ductile iron yoke and packing follower. The C132S features a solid cast stainless steel body with heavy duty cast stainless steel yoke, and packing follower, and all stainless steel bolting. Standard body materials are 316 and 317L stainless steel. Special materials such as 254 SMO® are also available.

## Available Options

- "D" Ring Seat
- Lever Operator
- Hard Gate Material
- Nickel -TFE Coated Gate
- Epoxy Coating
- Flush Ports
- Centerline Buttons
- Locking Devices
- Live Loaded Packing
- Ratchet (STD)

## Materials of Construction

Part	Materials	
	C132R	C132S
Body and Chest	Cast stainless steel type 316 or 317L	Cast stainless steel type 316 or 317L
Seat	Integrally cast (optional "O" ring)	
Gate	Stainless steel of same grade used in body, finished to 63 RMS	
Yoke	Ductile iron	Cast 304 stainless steel
Yoke Bolting	Plated steel	Stainless steel
Packing	Acrylic/PTFE	
Packing Follower	Ductile iron w/plated steel bolting	304 stainless steel w/stainless steel bolting
Stem Nut	Acid resistant bronze	
Lubrication Fitting	Plated steel	
Ratchet Operator	Cast iron/carbon steel	
Operator Retaining Nut	Malleable iron	Stainless steel
Tab Washer	Stainless steel	

## Specifications

- Size Range** 3"
- Pressure Rating** 150 psi (10.3 bar) CWP (cold working pressure)
- Temperature Rating** 450°F (232°C) with standard packing. Consult factory for higher temperatures.
- Flanges Drilling** Outlet ANSI 125/150 drilling  
Inlet special

## Testing

Every Fabri-Valve Figure C132 valve is fully tested prior to shipment. Testing includes a body shell test, a seat test, and a cycling test to insure proper functioning of moving parts. Additional testing is also available. Please let us know your requirements.

### Standard Shell test:

- Hydro test at 1.5 times the rated CWP (cold working pressure) – Zero allowable leakage

### Standard Seat test:

- Metal Seat: Hydro test at 40 psi (2.8 bar) and at the rated CWP
- Resilient Seat: Hydro test at 15 psi (1 bar) and rated CWP

## Shutoff Performance

- Integral Metal seat: 40cc / minute / inch of valve size
- "D" ring Zero leakage. All sizes.

Dimensions, Inches (mm)

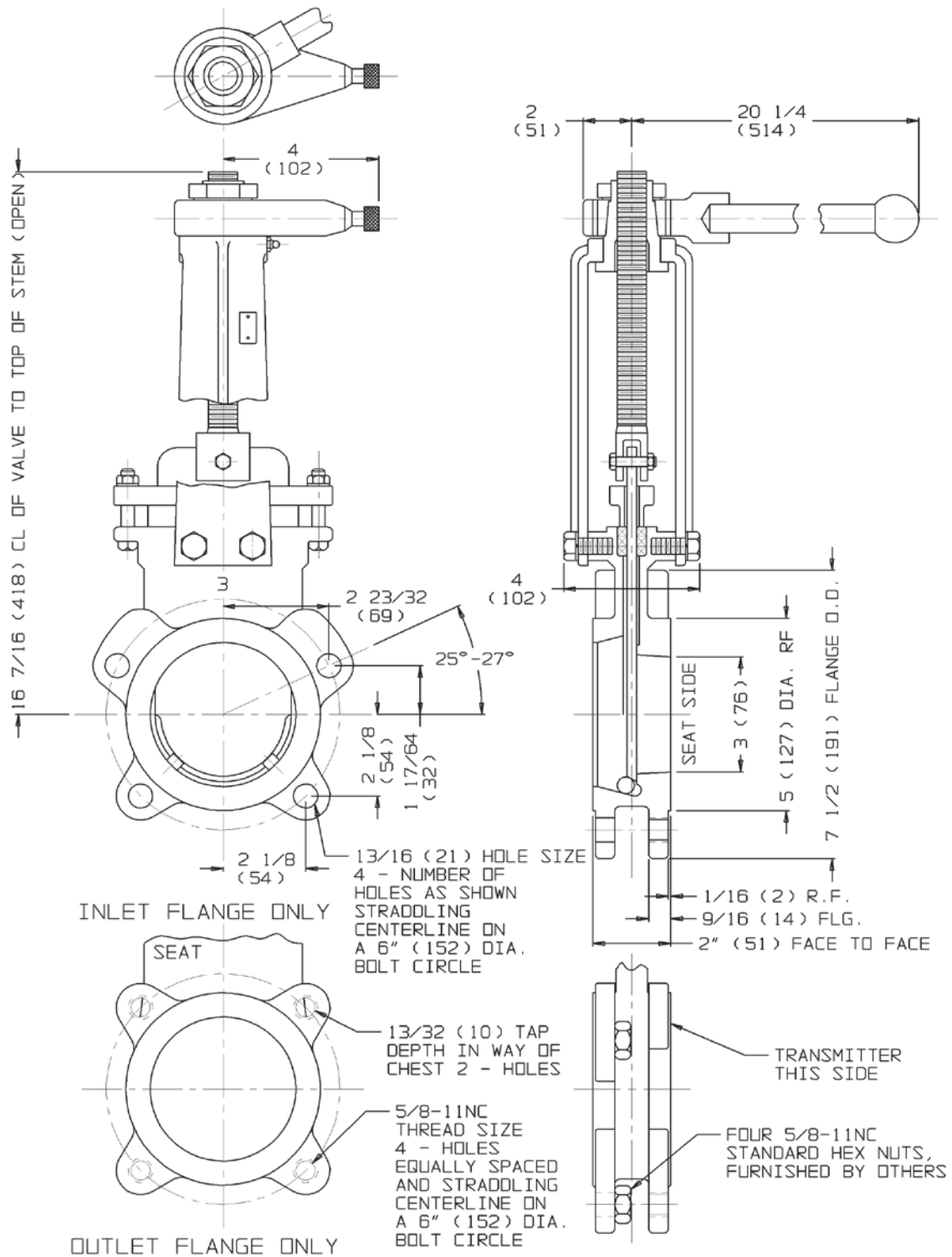

Total Weight: 21 lbs (10kg)



ENGINEERED FOR LIFE

Engineered Valves, LLC  
1110 Bankhead Ave  
Amory, MS 38821  
662.256.7185  
[www.engvalves.com](http://www.engvalves.com)

© 2012 ITT Engineered Valves, LLC

Form C132