

Fabri-Valve®

CF33/CF133

Ported Slide Gate Valve



**ITT**

ENGINEERED FOR LIFE

# CF33/CF133 Ported Slide Gate Valve



Figure C133 with energized cored packing.

Energized cored packing is standard with 6" (DN 150) and larger C33/C133 valves and all F33/F133 valves.

Fabri-Valve Figures C33 / C133 / F33 / F133 are bi-directional soft seated, slide gate valves designed for on/off service in heavy slurries. Specially designed body liners and constant contact seats minimize seat stress ensuring exceptional service life. Seats are self gasketing and are compatible with raised or flat faced, lined or unlined flanges. Figures C/F133 have a containment bonnet attached to the bottom flange to capture any discharge during cycling.

## Specifications

### Size Range

2" – 72"

### Pressure Rating

2" – 24" : 150 (10.3 bar) CWP (cold working pressure)

26" and larger are rate to customer requirement.

Designs to 360 psi (24.8 bar) are available, Consult Factory.

### Temperature Rating

2" – 72": 200°F (93°C).

Higher temperature designs are available, Refer to section "Pressure/Temperature Rating (Soft Components)".

### Flange Drilling

ANSI 125/150

## Testing

Every Fabri-Valve Figure C/F33 and C/F133 is tested prior to shipment. Testing includes a seat test and a cycling test to insure proper functioning of moving parts. Figures C133 and F133 are also body shell tested.\* Additional testing is also available. Please let us know your requirements.

\* Figures C33 and F33 seats are designed to restrict discharge in the open and closed positions (see seat test); therefore, Figures C33 and F33 are not body shell tested.

### Shell test:

Hydro test at 1.5 times the rated CWP – allowable leakage is zero

### Dual Resilient seat test:

Hydro test at 15 psi (1 bar) and rated CWP – Zero water leakage

## Available Options

- Dual Seats (STD)
- Hard Gate Material
- Nickel -TFE Coated Gate
- Epoxy Coating
- Flush Ports: Standard on C133
- Locking Devices (STD)
- E-Z Spin Handwheel
- Live Loaded Packing
- Chest Liners (STD)
- Self-Supporting Yokes
- Alternate Flange Drilling
- Bevel Gear
- Chainwheels
- Cylinder Actuators
- Electric Actuators
- Ratchet
- Extended Stems
- Gate Support Strips
- Rod Boots (STD)
- Splashguards (with oversized drain ports)

## Pressure/Temperature Ratings

The tables below are the maximum pressure/temperature ratings for the metallic components only. When checking pressure/temperature ratings, check the temperature rating and chemical compatibility of the packing material, and if applicable, the resilient

seat material. In a majority of designs, the temperature limit or the chemical compatibility of the seat and/or packing material determines the practical pressure/temperature limitations.

Figure C33 & C133							
Pressure-Temperature Rating - psi							
Temp		Cast 304L	Cast 316	Cast 316L	Cast 317L	Cast WCB A-216	Cast DI
°F	°C						
150	66	150	150	150	150	150	150
200	93	142	150	150	135	150	150
250	121	135	142	142	128	150	147
300	149	129	134	134	121	150	143
350	177	123	128	128	116	150	139
400	204	118	123	123	112	150	135
450	232	114	118	118	108	150	131
500	260	111	114	114	105	150	127

Figure F33 & F133								
Pressure-Temperature Rating - psi								
Temp		304	304L	316	316L	317L	A-36	A516Gr70
°F	°C							
150	66	150	133	150	133	150	150	150
200	93	133	114	141	113	135	137	150
250	121	126	108	133	107	128	135	150
300	149	120	102	124	101	121	133	150
350	177	115	98	119	97	116	131	150
400	204	110	93	114	93	112	128	150
450	232	107	90	110	90	108	125	150
500	260	103	87	106	87	105	121	150

### Pressure/Temperature Ratings (Soft Components)

Seat Material	Support Ring/Liner Material	Maximum Pressure/Temp.
EPDM	UHMW-P	150psi/200°F
EPDM	Carbon/PTFE	150psi/280°F
Viton, Aflas	Carbon/PTFE	150psi/350°F
Buna-N	UHMW-P	150psi/200°F
Buna-N	Carbon/PTFE	150psi/280°F

## Flow Coefficients

The Cv values below represent U.S. gallons per minute 60°F water through a 100% open valve at a pressure drop of 1 psi. The metric equivalent, Kv, is the flow of water at +16°C through the valve in cubic meters per hour at a pressure drop of 1 kg/cm2. To convert Cv to Kv, multiply the Cv by 0.8569.

Figure C33 / F33 / C133 / F133			
Valve Size		Handwheel Dia. (in.)	Rimpull and Number of Turns
In.	DN		
2	50	10	19 lb, 11 turns
3	75	18	13 lb, 15 turns
4	100	18	16 lb, 19 turns
6	150	18	21 lb, 28 turns
8	200	20	32 lb, 36 turns
10	250	20	42 lb, 45 turns
12	300	20	54 lb, 54 turns
14	350		3:1 BG W/12"Hw, 50 lb, 180 turns
16	400		4:1 BG W/12"Hw, 48 lb, 272 turns
18	450		4:1 BG W/12"Hw, 70 lb, 304 turns
20	500		4:1 BG W/18"Hw, 58 lb, 338 turns
24	600		4:1 BG W/24"Hw, 64 lb, 408 turns
30	750		16:1 BG W/12"Hw, 67 lb, 2064 turns
36	900		16:1 BG W/18"Hw, 66 lb, 2486.5 turns
42	1050		16:1 BG W/24"Hw, 69 lb, 2909 turns
48	1200		24:1 BG W/24"Hw, 56 lb, 4997 turns

Figure C33 / C133 / F33 / F133				
Cv Ratings, Port Diameter and Area				
Valve Size		Standard Port		
In.	DN	Cv	Port I. D Inches	Port Area Sq. In.
2	50	290	2.00	3.1
3	75	650	3.00	7.1
4	100	1150	4.00	12.6
6	150	2590	6.00	28.3
8	200	4610	8.00	50.3
10	250	7200	10.00	78.5
12	300	10370	12.00	113.1
14	350	12640	13.25	137.9
16	400	16740	15.25	182.6
18	450	21420	17.25	233.7
20	500	26680	19.25	291.0
24	600	38920	23.25	424.6
30	750	61600	29.25	671.9
36	900	89460	35.25	975.9
42	1050	122510	41.25	1336.4
48	1200	160740	47.25	1753.4

\*Differential Pressure has little effect on the Rimpull

BG = Bevel Gear

## Dimensions: C133 with Handwheel or Cylinder

Valve Size		TABLE 1 DIMENSION Inches (mm) C133 with HANDWHEEL OR CYLINDER																		
Inches	DN	A			C			D		H	J	M	N	P	Q	S	W	X	Y	Z
		HW	4 CYL	5 CYL	HW	4 CYL	5 CYL	4 CYL	5 CYL											
2	50	21-1/2 (546)	21 (533)	21 (533)	10 (254)	4-1/2 (114)	5-1/2 (140)	3/8-18	3/8-18	2 (51)	6 (152)	5/8-11NC	4	4-3/4 (121)	2-1/8 (54)	4-15/16 (125)	1-7/8 (48)	7 (178)	5-15/16 (151)	3/8 (10)
3	80	24-1/4 (616)	23-7/16 (595)	23-11/16 (601)	18 (457)	5-1/2 (140)	6-1/2 (165)	3/8-18	3/8-18	3 (76)	7-1/2 (191)	5/8-11NC	4	6 (152)	2-1/4 (57)	4-15/16 (125)	2 (51)	8-3/4 (222)	7-7/16 (189)	27/64 (11)
4	100	27 (686)	26-3/16 (665)	26-7/16 (672)	18 (457)	5-1/2 (140)	6-1/2 (165)	3/8-18	3/8-18	4 (102)	9 (229)	5/8-11NC	8	7-1/2 (191)	2-1/4 (57)	4-15/16 (125)	2 (51)	10-1/4 (260)	8-15/16 (227)	27/64 (11)
6	150	32-1/16 (814)	31-1/2 (800)	32 (813)	18 (457)	6-1/2 (165)	8-5/8 (219)	3/8-18	3/8-18	6 (152)	11 (279)	3/4-10NC	8	9-1/2 (241)	3-3/4 (95)	7-3/8 (187)	2-1/4 (57)	12-1/8 (308)	6-5/8 (168)	33/64 (13)
8	200	40-13/16 (1037)	37-3/8 (949)	37-3/4 (959)	20 (508)	8-5/8 (219)	10-7/8 (276)	3/8-18	1/2-14	8 (203)	13-1/2 (343)	3/4-10NC	8	11-3/4 (298)	3-7/8 (98)	7-3/8 (187)	2-3/4 (70)	15-13/16 (402)	7-3/4 (197)	5/8 (16)
10	250	46-1/8 (1172)	43-1/2 (1105)	44-1/8 (1121)	20 (508)	8-5/8 (219)	10-7/8 (276)	3/8-18	1/2-14	10 (254)	16 (406)	7/8-9NC	12	14-1/4 (362)	4-1/2 (114)	7-3/8 (187)	2-3/4 (70)	19-7/8 (505)	9-1/4 (235)	19/32 (15)
12	300	52-1/8 (1324)	49-7/16 (1256)	50-1/4 (1276)	20 (508)	8-5/8 (219)	10-7/8 (276)	3/8-18	1/2-14	12 (305)	19 (483)	7/8-9NC	12	17 (432)	4-1/2 (114)	7-1/2 (191)	3 (76)	23-1/4 (591)	10-1/4 (273)	23/32 (18)
14	350	Note 1	58-1/2 (1486)	58-1/2 (1486)	N/A	12-3/4 (324)	12-3/4 (324)	1/2-14	1/2-14	13-1/4 (337)	21 (533)	1-8NC	12	18-3/4 (476)	6-5/8 (168)	11-1/4 (286)	2-7/8 (73)	26-1/8 (664)	12-7/8 (327)	1/2 (13)
16	400	Note 1	64-9/16 (1640)	65-11/16 (1668)	N/A	12-3/4 (324)	14-3/4 (375)	1/2-14	3/4-14	15-1/4 (387)	23-1/2 (597)	1-8NC	16	21-1/4 (540)	7-3/4 (197)	11-1/4 (286)	3-3/8 (86)	28-11/16 (729)	14-1/8 (359)	3/4 (19)
18	450	Note 1	69-13/16 (1773)	70-15/16 (1802)	N/A	12-3/4 (324)	14-3/4 (375)	1/2-14	3/4-14	17-1/4 (438)	25 (635)	1-1/8-7NC	16	22-3/4 (578)	8-1/8 (206)	11-1/2 (292)	3-3/8 (86)	31-7/8 (810)	14-3/4 (375)	23/32 (18)
20	500	Note 1	77-5/16 (1964)	77-9/16 (1970)	N/A	14-3/4 (375)	17 (432)	3/4-14	3/4-14	19-1/4 (489)	27-1/2 (699)	1-1/8-7NC	20	25 (635)	9-3/4 (248)	11-1/2 (292)	4-1/2 (114)	35-3/8 (899)	16-1/4 (413)	1-3/16 (30)
24	600	Note 1	90 (2286)	91-1/4 (2318)	N/A	17 (432)	19 (483)	3/4-14	3/4-14	23-1/4 (591)	32 (813)	1-1/4-7NC	20	29-1/2 (749)	10-7/8 (276)	11-1/2 (292)	4-1/2 (114)	42-1/16 (1068)	19-3/4 (502)	1-1/8 (29)

Note 1: Use Bevel Gear.

Reference Dimensions in (parentheses)

\* Figures C133 and F133 have a containment bonnet attached to the bottom flange to capture any discharge during cycling.

As standard, remote operated Figure C33 and F33 valves are equipped with a bottom shroud to protect personnel during cycling. Specify Figure C133 or F133 if media discharged during cycling must be contained.

# C133 with Handwheel or Cylinder

Refer to TABLE 1 for dimensions

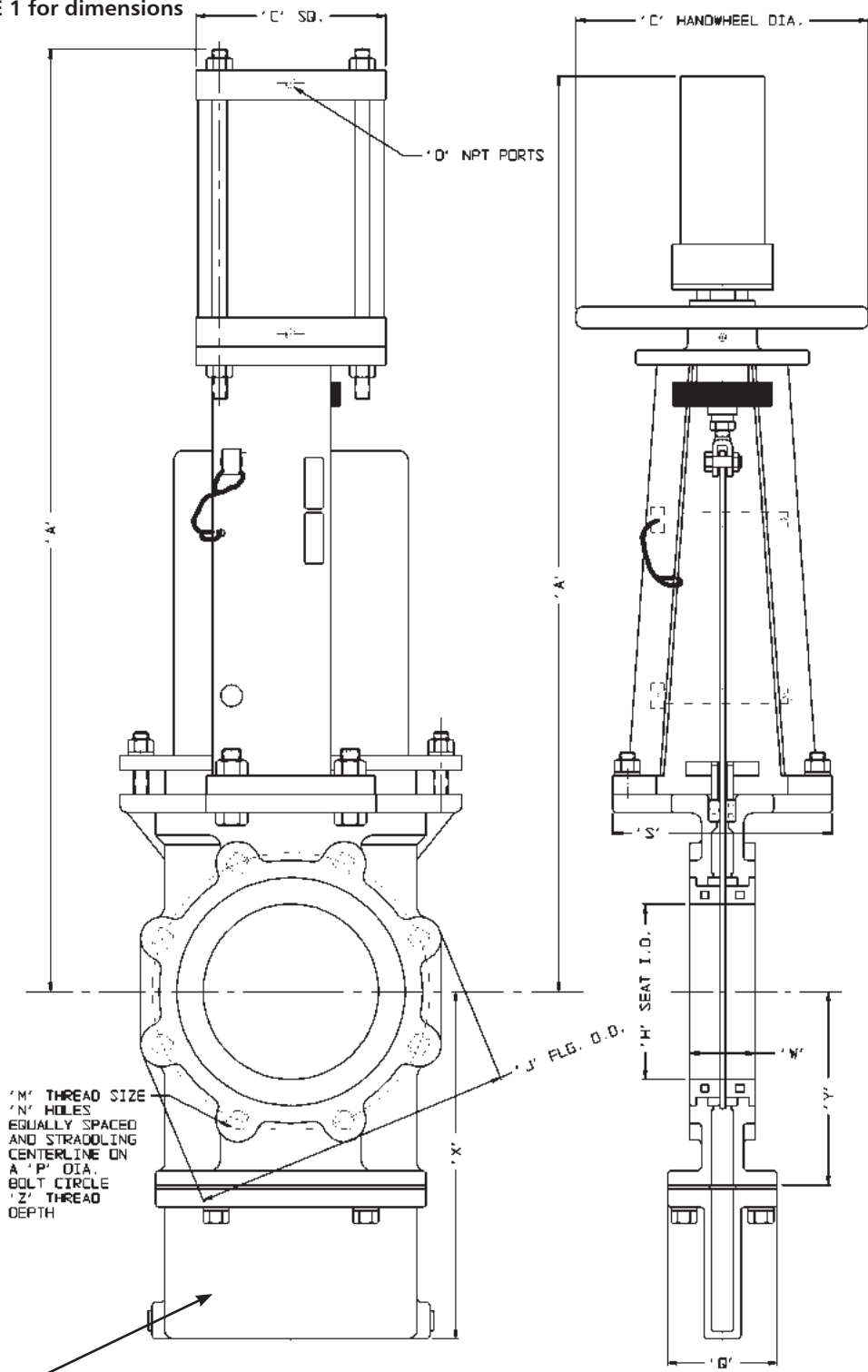

Figures C133 and F133 have a containment bonnet attached to the bottom flange to capture any discharge during cycling.

with Cylinder

with Handwheel

## Dimensions: C133 with Bevel Gear

Valve Size		TABLE 2 DIMENSION Inches (mm) C133 with BEVEL GEAR															
Inches	DN	A	B*	C*	D*	E	H	J	M	N	P	Q	S	W	X**	Y	Z
14	350	55-3/16 (1402)	41-5/16 (1049)	12 (305)	12-1/16 (306)	6-1/2 (165)	13-1/4 (337)	21 (533)	1-8NC	12	18-3/4 (476)	6-5/8 (168)	11-1/4 (286)	2-7/8 (73)	26-1/8 (664)	12-7/8 (327)	1/2 (13)
16	400	61-1/4 (1556)	45-3/8 (1153)	12 (305)	12-1/16 (306)	6-1/2 (165)	15-1/4 (387)	23-1/2 (597)	1-8NC	16	21-1/4 (540)	7-3/4 (197)	11-1/4 (286)	3-3/8 (86)	28-11/16 (729)	14-1/8 (359)	3/4 (19)
18	450	67-1/8 (1705)	48-5/8 (1235)	18 (457)	13-9/16 (344)	6-1/2 (165)	17-1/4 (438)	25 (635)	1-1/8-7NC	16	22-3/4 (578)	8-1/8 (206)	11-1/2 (292)	3-3/8 (86)	31-7/8 (810)	14-3/4 (375)	23/32 (18)
20	500	73-3/8 (1865)	52-7/8 (1343)	18 (457)	13-9/16 (344)	6-1/2 (165)	19-1/4 (489)	27-1/2 (699)	1-1/8-7NC	20	25 (635)	9-3/4 (248)	11-1/2 (292)	4-1/2 (114)	35-3/8 (899)	16-1/4 (413)	1-3/16 (30)
24	600	85-9/16 (2173)	60-11/16 (1541)	24 (610)	15-1/16 (383)	6-1/2 (165)	23-1/4 (591)	32 (813)	1-1/4-7NC	20	29-1/2 (749)	10-7/8 (276)	11-1/2 (292)	4-1/2 (114)	42-1/16 (1068)	19-3/4 (502)	1-1/8 (29)

Reference Dimensions in (parentheses)

\* Bevel Gear Ratio is 3:1 (14"); 4:1 (16"- 24")

\*\* Figures C133 and F133 have a containment bonnet attached to the bottom flange to capture any discharge during cycling.

## Materials of Construction

Part	Materials	
	C33S and C133S	C33R and C133R
Body	Stainless grade per Customer Specification	Stainless grade or Ductile Iron per Customer Specification
Support Ring	Standard: UHMW-P	
Yoke Assembly	304 SS	Carbon steel
Replaceable Seat	Standard: EPDM	
Gate	Stainless grade per Customer Specification	
Handwheel	Cast iron <sup>2</sup>	Cast iron <sup>2</sup>
Stem Assembly / Cyl. Clamp	304 SS	304 SS/Carbon steel
Packing	Acrylic/PTFE/Silicone <sup>3</sup>	
Packing Gland	316 SS (2"-12"), Carbon Steel (14"-24" R), 316 SS (14"-24" S)	
Bonnet	SS as spec.	
Serial No. Tag	18-8 SS	
Fasteners	18-8 SS	Plated mild steel
Stem Nut <sup>1</sup>	Acid Resistant Bronze	
Grease Fitting (handwheel)	Plated mild steel	
Lanyard	18-8-SS	
Lockout Pin	304 SS <sup>4</sup>	
Rod Boot	Hypalon nylon	
Warning Tag	18-8 SS	
Stop Nut Assembly <sup>1</sup>	304 SS	304 SS/Carbon steel
Stop Nut <sup>1</sup>	304 SS	Carbon steel
Stem Cover <sup>1</sup>	304 SS	Carbon steel
Bonnet Gasket	Aramid fibers with NBR synthetic rubber	

<sup>1</sup> Handwheel and Bevel Gear

<sup>2</sup> Handwheel is Cast Iron; Bevel Gear is Carbon Steel

<sup>3</sup> Energized cored packing is standard with 6" (DN150) and larger C33/C133 valves and all F33/F133 valves.

<sup>4</sup> Valves with Cylinders have 17- 4 SS Lockout Pins

# C133 with Bevel Gear

Refer to TABLE 2 for dimensions

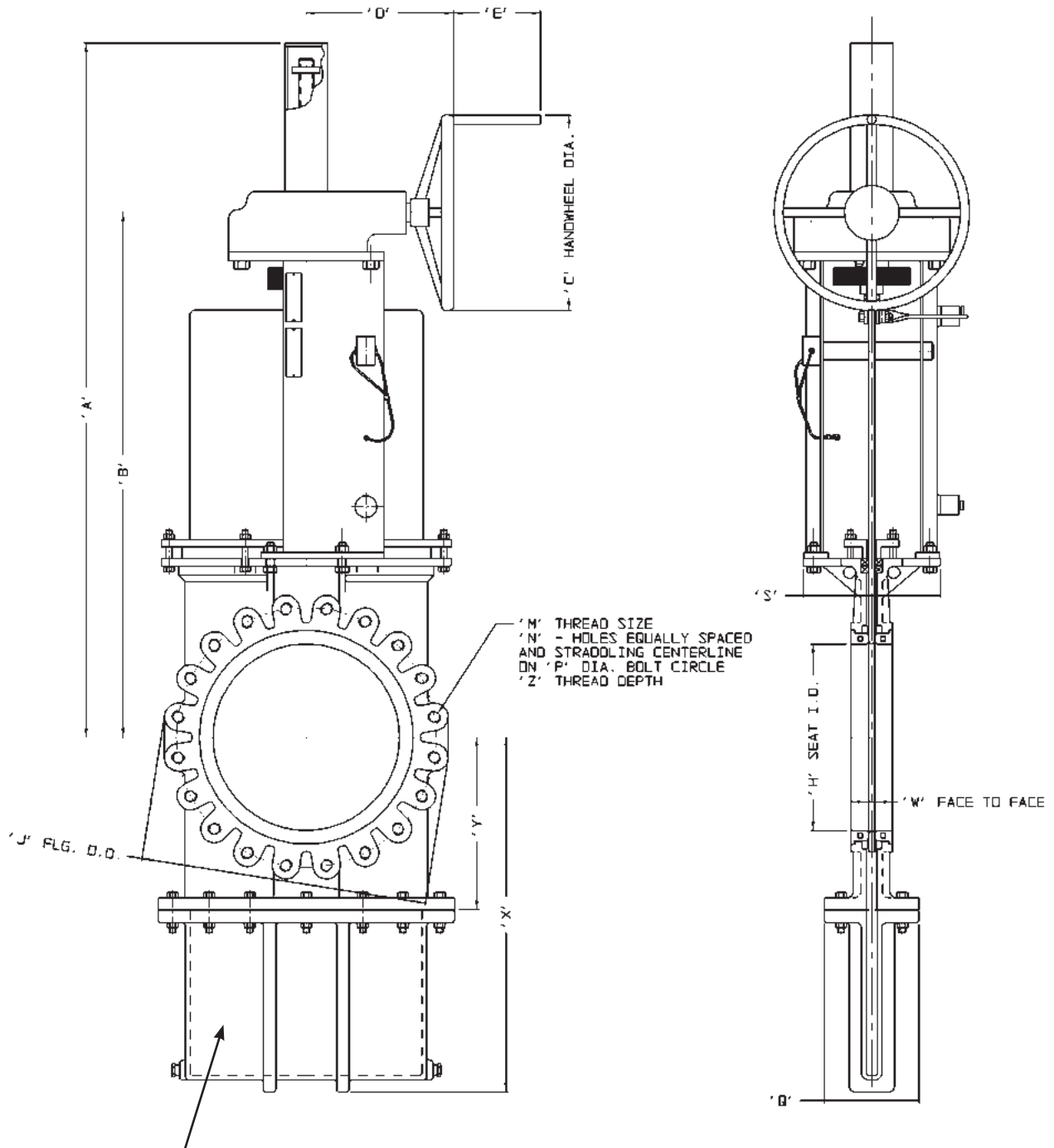

Figures C133 and F133 have a containment bonnet attached to the bottom flange to capture any discharge during cycling.



ENGINEERED FOR LIFE

Engineered Valves, LLC  
1110 Bankhead Ave  
Amory, MS 38821  
662.256.7185  
[www.engvalves.com](http://www.engvalves.com)

© 2012 ITT Engineered Valves, LLC

Form CF33/CF133