

# PTFE LINED HOSE

for Pharmaceutical and Biotech Process Fluids  
from Aflex Hose



BIOFLEX HOSE

CORROFLON HOSE

PHARMALINE HOSE

PHARMALEX HOSE

RE-LINK FITTING

# PTFE – THE OPTIMUM CHOICE FOR HOSE LININGS

PTFE, or **Polytetrafluoroethylene**, comprises long-chain molecules of carbon atoms, each linked to two fluorine atoms.

The fluorine atoms provide a helical spiral which surrounds the carbon chain and protects it.

It is this structure which creates the unique properties for which PTFE is well-known.

## EXCELLENT CHEMICAL RESISTANCE

PTFE is renowned as the most chemically resistant material known. Only a very few, very unusual substances and conditions can affect it, like fluorine gas at high temperature and pressure and liquid, boiling sodium metal.

PTFE lined hoses can therefore be used for a wider variety of chemicals than any other hose type, making it the ideal choice for very corrosive chemical applications and multi-product applications.

## NON-STICK SURFACE

The use of PTFE as a surface for cookware products has demonstrated to the world how easily cleanable PTFE surfaces are.

This means that PTFE lined hoses can be purged 100% clean more quickly, easily and reliably than any other type of hose.

## EXCELLENT TEMPERATURE RANGE

The cookware application also demonstrates another of PTFE's many attributes – temperature resistance. PTFE itself can be used as a hose liner at temperatures from  $-150^{\circ}\text{C}$  up to  $+260^{\circ}\text{C}$ , dependent upon the hose design and the application conditions.

This is the widest temperature range of any rubber or plastic hose lining material.

## HOSE DESIGN

The only issue with PTFE as a hose lining material is the best way it can be integrated in to the hose design. This is where Aflex Hose have a proven record of success over the last 30 years.

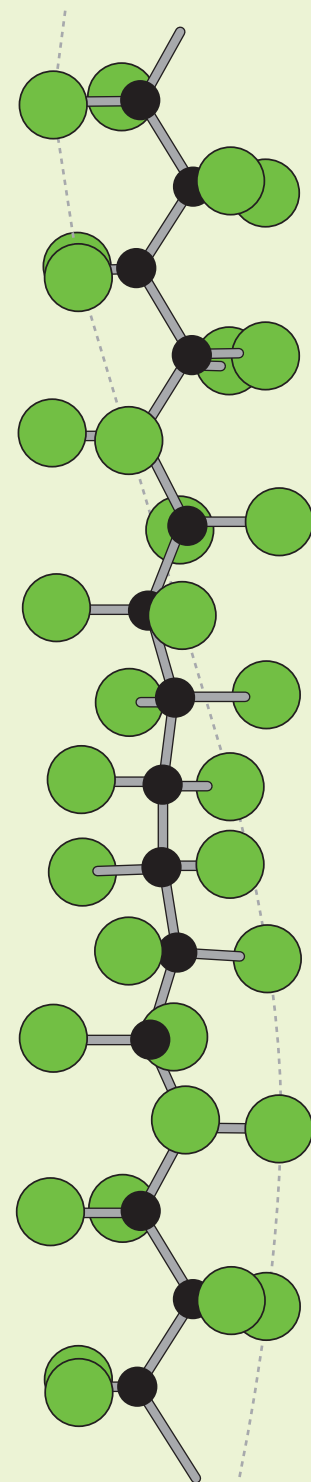

Section from a PTFE Molecule,  
16 Angstrom Units long

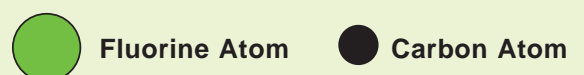



# INTRODUCTION TO AFLEX HOSE

**Aflex Hose was established as a PTFE hose manufacturing company in 1973 and, since then, has led the world in inventing and developing all the major innovations in PTFE hose design for use in process fluids transfer applications. Pharmaceutical, Biotech and Chemical manufacturing plants worldwide recognise the Aflex PTFE hose product range to be the best available, and have adopted them as 'site standard' over many years.**



Technically trained Aflex Hose sales staff are available to respond quickly and effectively to every kind of enquiry, and to advise the optimum hose solution for any application.

## **CUSTOM HOSES FOR CRITICAL ENVIRONMENTS**

Aflex Hose takes particular pride in our ability to design, specify and custom build special purpose hose assemblies to customers' non-standard requirements. From hose assemblies for fluorine, with non-standard hastelloy end fittings to an electrically trace heated hose assembly with a colour coded rubber cover for viscous fluids transfer – whatever the customer requires, Aflex Hose can develop a specific solution.

## **TOTAL MANUFACTURE**

The primary reason for our success is that Aflex is the only PTFE hose company in the world to carry out all the hose manufacturing operations ourselves, from raw materials to finished products, at our plants in Yorkshire (UK) and Pennsylvania (USA).

- PTFE powder is extruded into tube and convoluted
- Stainless steel or polypropylene yarn is wound and braided onto the tube
- Plastic and rubber extruders are used to apply external covers when required
- End fittings are machined from bar stock on state of the art CNC lathes
- And, finally, the hoses are assembled to individual customer requirements, tested and dispatched to end users

**Because of this, Aflex is able to achieve unbeatable levels of build quality, design excellence and economy of scale, which are unmatched by our competitors.**

## **CHEMICAL & GENERAL PROCESS FLUIDS**

Aflex Hose manufactures another range of PTFE lined hose products designed for use in Chemical applications, also other process fluids such as Foodstuffs, Paints, Resins etc. Corroline is described on the Aflex Hose website.

## **AUTOMOTIVE, MOTOR SPORT AND GENERAL PURPOSE APPLICATIONS**

Aflex Hose also manufactures another range of PTFE hose products for use in automotive, motor sport and general industrial applications. The Smoothbore and Hydraline FX, SB and V ranges of hose are described in another brochure, and information is also available on our website.

# BIOFLEX HOSE

The introduction of Bioflex hose in 1998 was the most important advance in PTFE hose design to take place in the last 20 years.

There had been a long-recognised need for a PTFE lined hose with the flexibility of a convoluted hose, but with a smooth bore.

The smooth bore was requested for two main reasons: firstly, for inner cleanability, in order to avoid fluids being trapped in the convolutions; and secondly, to overcome the turbulent flow induced in convoluted hose bores, which severely reduces the flow rates through the hose.

The key feature of Bioflex PTFE hose is the PTFE liner tube design, comprising integral rib sections which support the tube against kinking, vacuum and pressure, and highly compressed web sections which give a smooth bore inner surface and excellent flexibility.

## CONVENTIONAL CONVOLUTED PTFE LINER

- Fluid can be trapped in the convolutions
- Fluid flow is turbulent, and slow

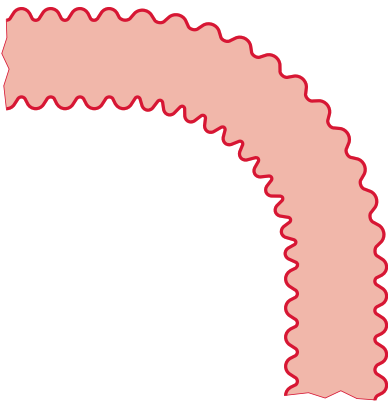

## BIOFLEX PTFE LINER

- Fluid is not trapped and the hose is self-draining
- Fluid flow is laminar, and fast

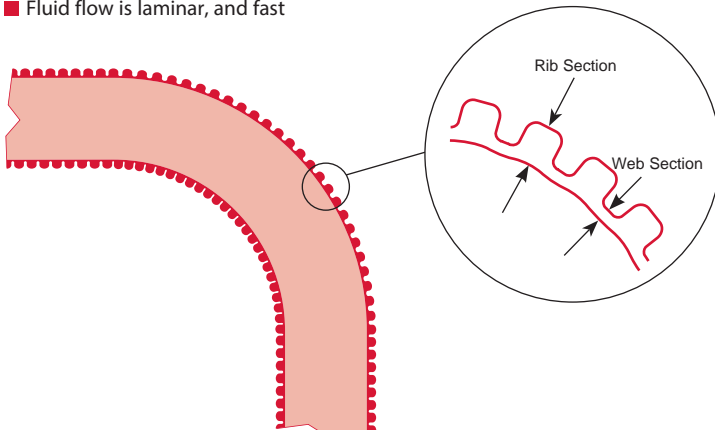

## Bioflex Hose Assembly with an Integral PTFE Lined Triclover Fitting



# BIOFLEX HOSE

Another feature is the integral PTFE lined and flared end fitting design which is available for all standard end fittings applied to Bioflex hose assemblies. This provides clean, full-bore flow through the end fitting without any restrictions or entrapment points – unlike conventional fittings, which introduce a bore restriction, also an entrapment crevice at the inside end of the fitting tail. Much higher flow rates are achieved, in comparison with conventional fittings, reducing the time required to fill/empty vessels through the hose.

**Bioflex has become the established standard in high purity process fluid applications all over the world, and continues to be introduced into new applications every day.**

## SIZE RANGE

- $\frac{3}{8}$ " (9.5mm) up to 2" (50mm)

## HOSE DESIGN OPTIONS

- Natural or anti-static PTFE, stainless steel braid, with or without an EPDM or silicone rubber cover, or polypropylene, PVDF or hastelloy braid

## END FITTING OPTIONS

- ASA150 or DIN flanges, Sanitary Triclamps (Triclovers), Camlocks, DIN11851, RJT, RJP and SMS fittings, BSPT or NPT fixed males, BSP or NPSM females, JIC, I-Line and many other standard and special fitting designs

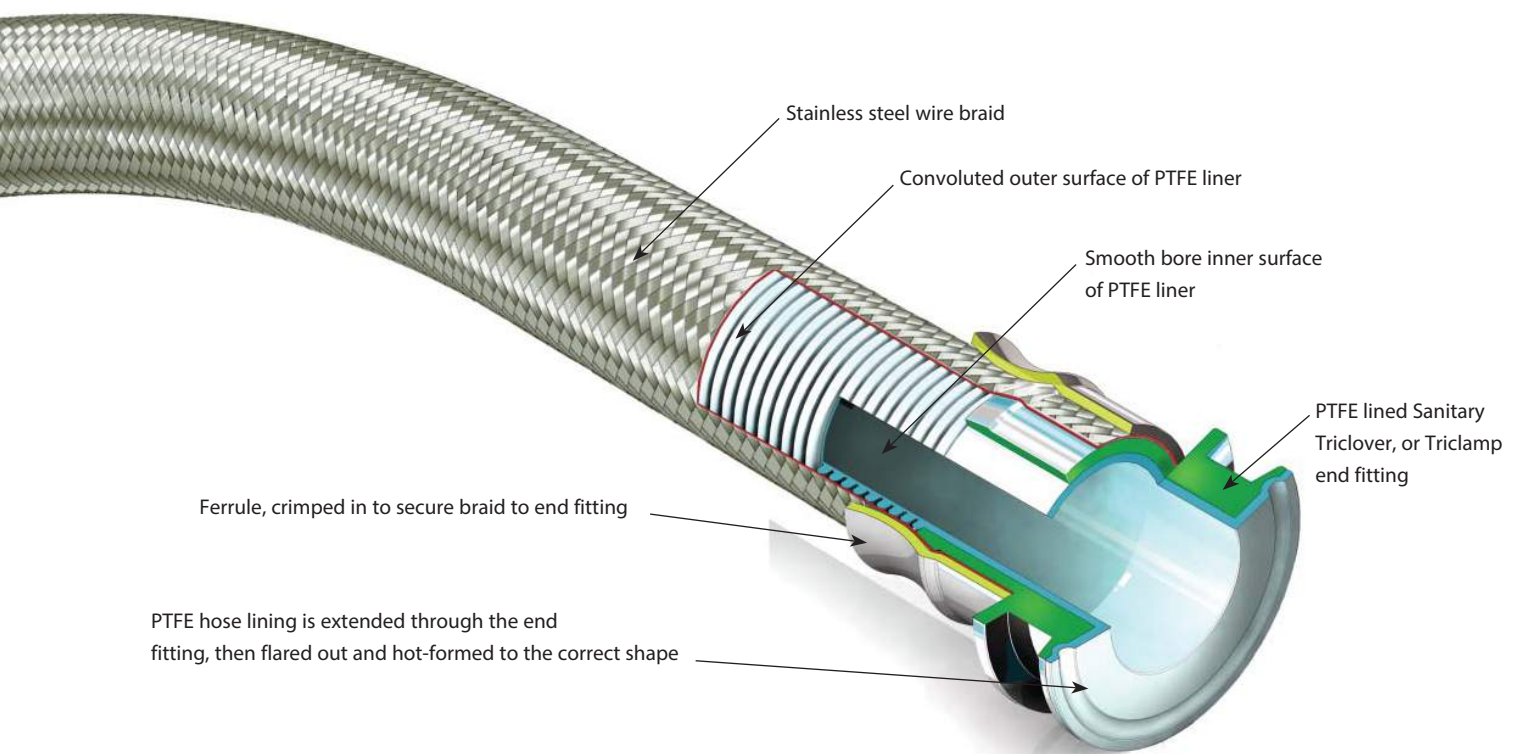

**NOTE:** The bore size of the hose is maintained right through the end fitting.

## ADVANTAGES

1. No bore restriction at the ends, as with conventional inserted fittings, therefore higher flow rates.
2. Free, cleaner flow of fluid, without the fluid entrapment which occurs at the inside end of an inserted fitting.

## CORROFLON HOSE

**Corroflon hose was the first convoluted PTFE lined hose product in the world to be developed specifically for process fluids transfer applications in pharmaceutical and chemical plants.**

Corroflon was launched in 1978, and since then all of the major advances in convoluted PTFE hose design have been pioneered by Aflex Hose and incorporated into the Corroflon hose product range. These include anti-static PTFE, polypropylene braid, and EPDM or silicone rubber hose covers. Aflex Hose also developed and introduced PTFE lined and flared end fittings which protect the end fitting from contact with the process fluid, and provide clean, uninterrupted fluid flow through the end fitting.

Over the years, Corroflon hose and end fittings have been continuously developed and improved to maintain market leadership, and design features which have been identified as prime requirements have been incorporated at every stage.

These include the thickest wall and the best processed tube lining available, to prevent the development of porosity in the PTFE, which is the primary cause of premature failure in competitors' products.

Corroflon is also fully kink resistant and vacuum resistant due to the tight helical wire reinforcement and the convoluted design profile.

The build quality and design excellence of Corroflon hose have been tested and proved in numerous applications worldwide, and hundreds of thousands of Corroflon hoses have been applied and used successfully over the last 30 years.

**Corroflon Hose Assembly with a  
PTFE lined Swivelling Flange End Fitting**



# CORROFLON HOSE

## SIZE RANGE

- 1/2" (12.75mm) to 6" (150mm)

## HOSE DESIGN OPTIONS

- Natural or anti-static PTFE, stainless steel braid, with or without an EPDM or silicone rubber cover, or polypropylene, PVDF or hastelloy braid

## END FITTING OPTIONS

- ASA150 or DIN flanges, Sanitary Triclamps (Triclovers), Camlocks, DIN11851, RJT, RJP and SMS fittings, BSPT or NPT fixed males, BSP or NPSM females, JIC, I-Line and many other standard and special fitting designs

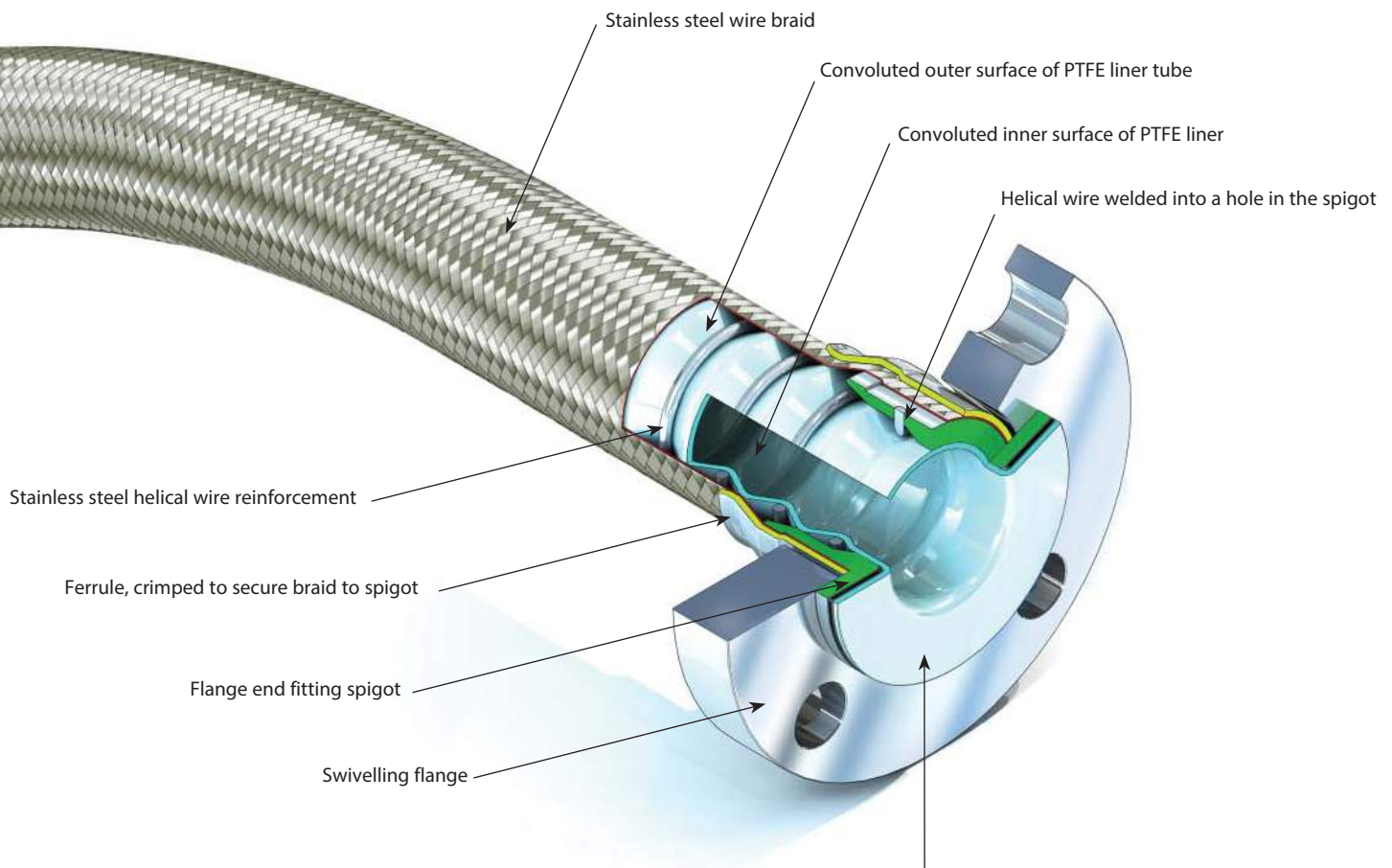

PTFE liner tube extended through the end fitting, then flared out to form the sealing face.

## ADVANTAGES

1. Internally "wetted" parts are all PTFE, protecting the end fitting from any corrosive fluids.
2. No bore restriction, so fluid flow through the fitting is clean, without entrapment zones.

# PHARMALINE HOSE

**Pharmaline is a unique, genuinely smooth bore PTFE lined hose product, based on the same patented PTFE hose liner design developed for Bioflex hose.**

Pharmaline is designed to overcome the very poor flexibility of currently available silicone rubber covered smooth bore PTFE hose products.

Pharmaline is also designed to offer a replacement for silicone rubber hose providing much better chemical resistance and steam resistance (during autoclave sterilisation) and much improved ease of cleaning.

Pharmaline hose assemblies are manufactured to meet USP VI, FDA and all other specification requirements (see page 11).

Unlike Pharmalex (page 09) Pharmaline includes a stainless steel wire braid to reinforce the hose construction against internal pressure and mechanical abuse in applications which require this. The braid is covered with an extruded, pure white silicone rubber with a smooth, easy-clean surface finish.

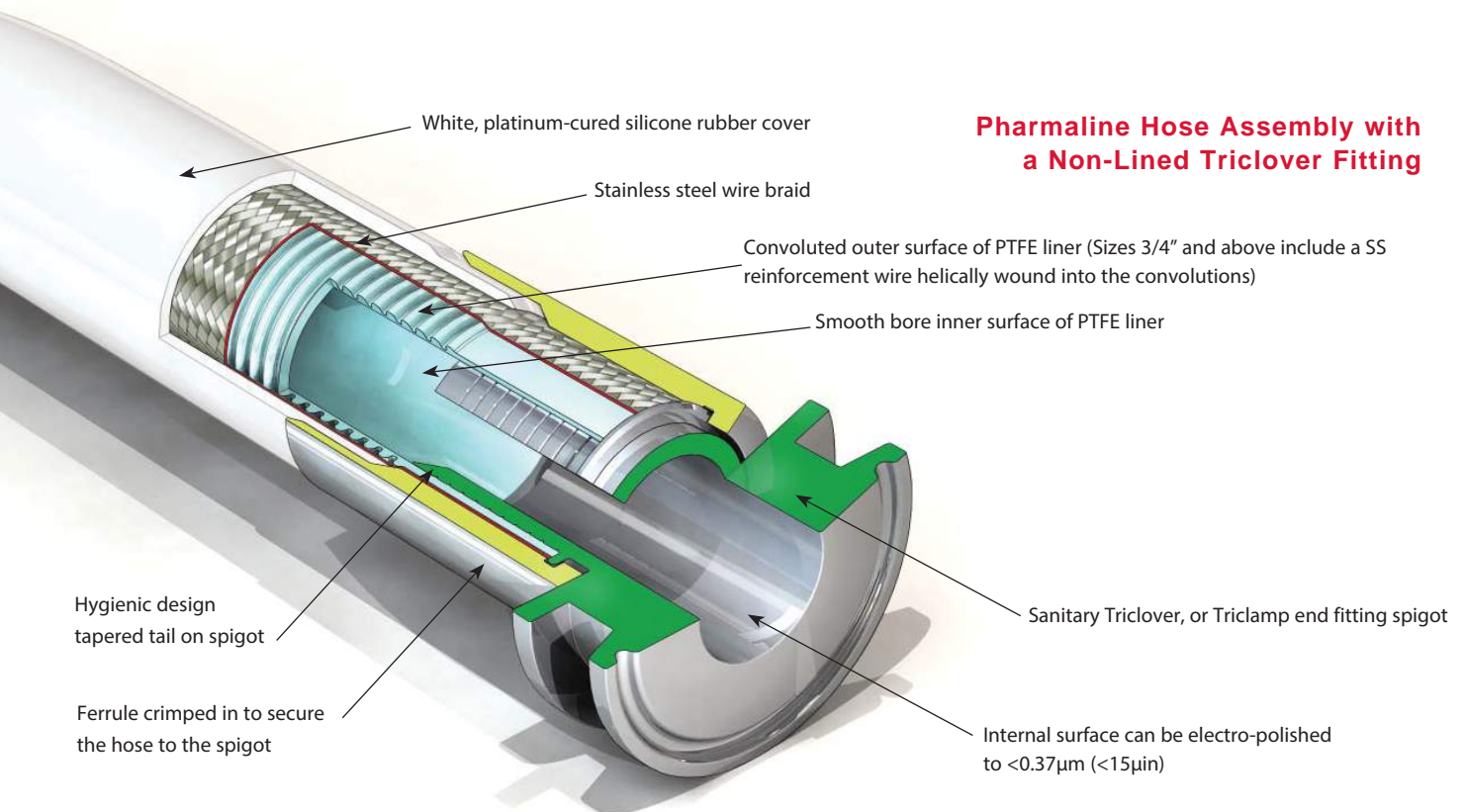

The primary application area for Pharmaline is in high purity pharmaceutical, biotech, chemical and foodstuffs plants where ease of cleaning the hose, both internally and externally is required.

Pharmaline is also very suitable for use in other general industrial applications, particularly those where hot fluids or gases are being passed, if there is any risk of burns due to accidental touching of the hose – for example, hot oil or steam transfer applications.

## SIZE RANGE

- 1/4" (6.6mm) up to 2" (50mm)

## HOSE DESIGN OPTIONS

- Natural or anti-static PTFE

## END FITTING OPTIONS

- Sanitary and mini tri-clamp Triclover fittings, I-Line fittings, DIN11851 and Aseptic fittings, Neumo and other hygienic fitting designs, Re-Link fittings – re-usable self-assembly fittings (page 10)



# PHARMALEX HOSE



**Pharmalex is a unique, genuinely smooth bore PTFE lined hose product based on the patented PTFE hose liner design developed for Bioflex hose.**

Pharmalex is designed to overcome the very poor flexibility of currently available PTFE tube products.

Pharmalex is also designed to offer a replacement for silicone rubber hose and tube, providing much better steam and chemical resistance and much improved ease of cleaning.

Pharmalex hose assemblies are manufactured in 'clean room' conditions and meet USP VI, FDA and all other specification requirements (see page 11).

Unlike Pharmaline, Pharmalex does not include an SS wire braid in its construction, and so is more suitable for low pressure, light duty applications.

The silicone rubber cover over the PTFE tube is transparent, permitting some visual inspection of fluids passing through.

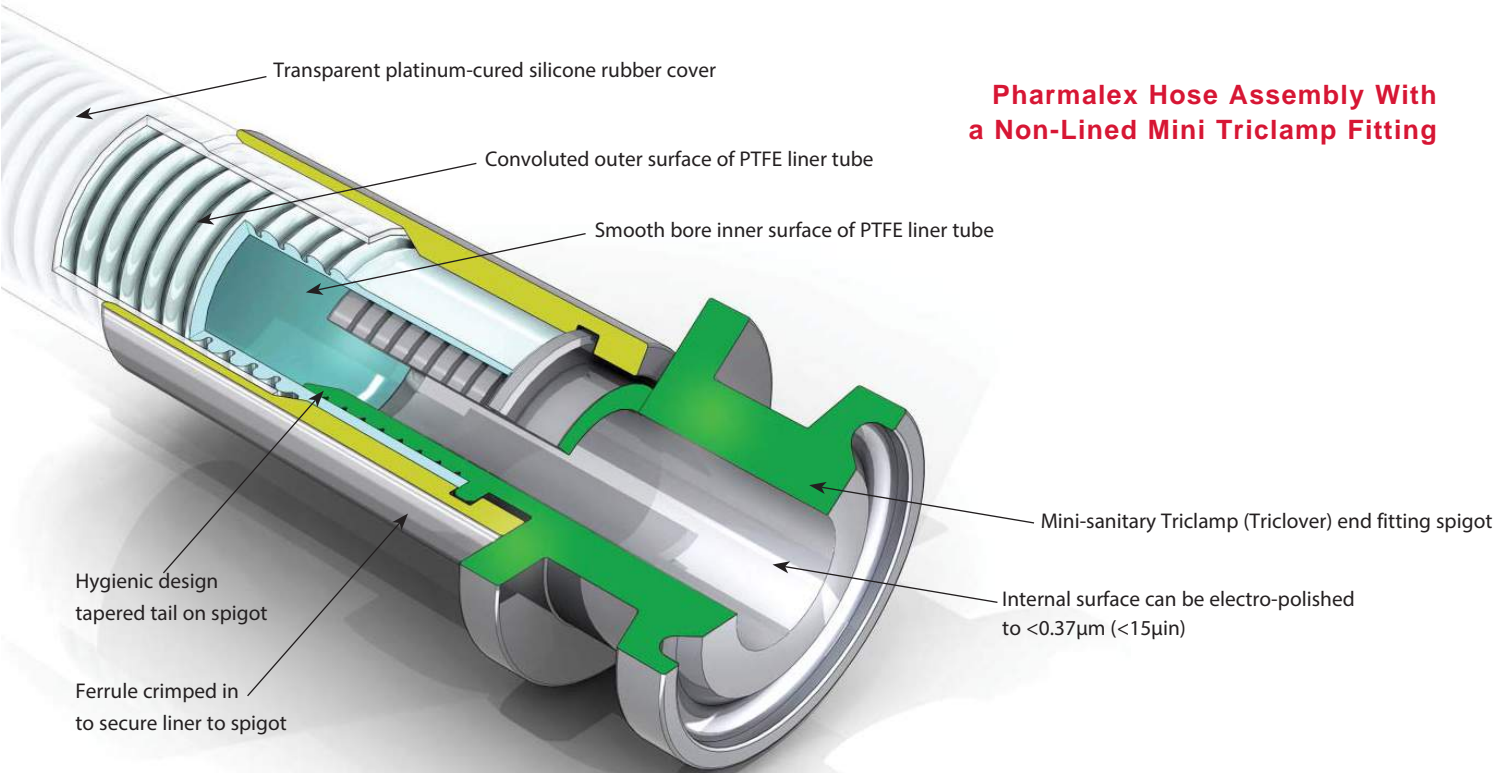

## Pharmalex Hose Assembly With a Non-Lined Mini Triclamp Fitting

Pharmalex is designed for use in high purity pharmaceutical, biotech, chemical and foodstuffs application areas where ease of cleaning the hose internally and externally is required.

Pharmalex is also very suitable for use in other general industrial applications, particularly those where hot or corrosive fluids are being passed.

### SIZE RANGE

- 1/4" (6.6mm) up to 1" (25mm)

### HOSE DESIGN OPTIONS

- Natural or anti-static PTFE

### END FITTING OPTIONS

- Sanitary and mini tri-clamp Triclover fittings, I-Line fittings, DIN11851 and Aseptic fittings, Neumo and other hygienic fitting designs, Re-Link fittings – re-usable self-assembly fittings (page 10)

## RE-LINK END FITTING SYSTEM (patent pending)

The Re-Link end fitting system is a unique system for attaching standard end fittings on to Pharmaline or Pharmalex, using a simple portable hand press, or a hydraulic press.

The end fitting can be 'self assembled' on site by the customer, and can also be disassembled so that the end fitting components can be re-used on another hose assembly if required.

### Re-Link Triclover Fitting on Pharmaline Hose

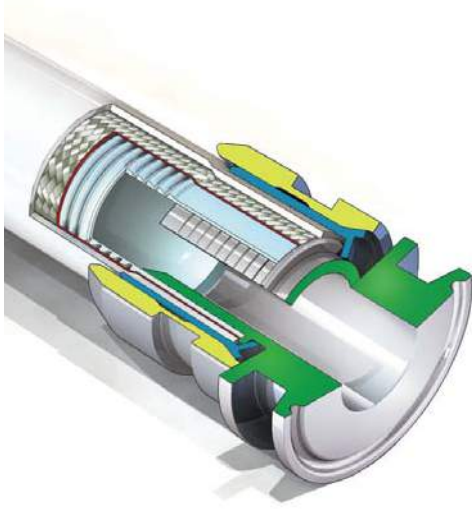

### Re-Link Components before Compression in Press

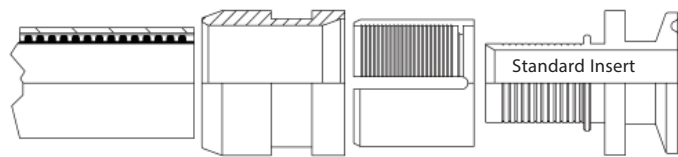

### Re-Link Fitting, Fully Compressed

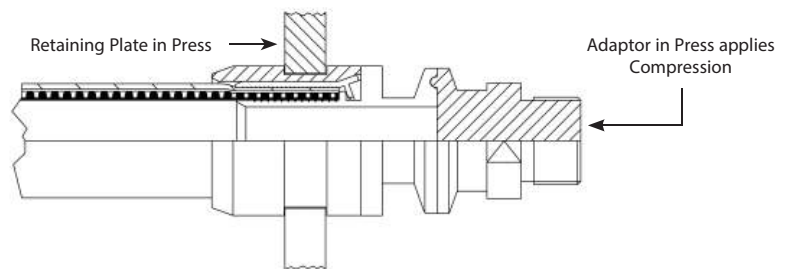

The Re-Link system was designed to overcome the disadvantages of the existing self-assembly, reusable-fitting design available from other suppliers.

## PURETAG INTEGRATED LABELLING SYSTEM

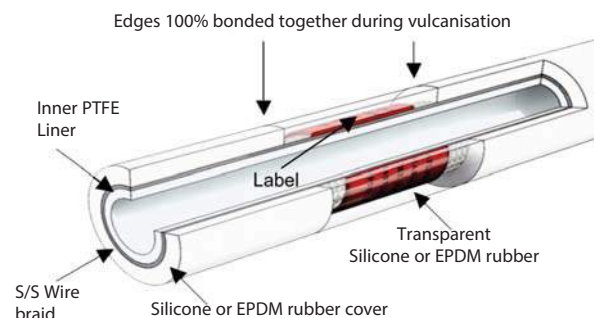

### DESCRIPTION

The Puretag labelling system (patent pending) comprises a label or colour code on the inner braid, encapsulated by a transparent, platinum cured silicone or transparent EPDM rubber cover which is integrally vulcanised and fully bonded to the rubber cover on the hose without any adhesive.

The encapsulation is flush with the external surface of the hose, to provide a streamlined design.

Puretag labels and/or colour codes can be applied to all the Silicone Rubber and EPDM rubber covered Aflex Hose Products, including Pharmaline, Pharmalex, Bioflex SI or RC or FP Hose and Corroflon SI or RC or FP Hose.

# QUALITY ASSURANCE, CERTIFICATION, TESTING & IDENTITY

## **BS EN ISO 9001:2008**

Aflex products are all manufactured in accordance with BS EN ISO 9001:2000 Quality Management Systems independently assessed and registered by National Quality Assurance Limited (NQA).

## **USP CLASS VI**

Natural and Antistatic PTFE Hose Liners, Platinum Cured Silicone Rubber Covers (White and Clear) and EPDM Rubber Cover (Blue) have been tested in accordance with USP protocols and are found to conform to the requirements of USP Class VI Chapter <88>.

Natural and Antistatic PTFE Hose Liners, Platinum Cured Silicone Rubber Covers (White and Clear) have also been tested in accordance with USP protocols and are found to conform to the requirements of USP Class VI Chapter <87>, the L929 MEM Elution Test and are considered non-cytotoxic.

## **FDA**

The materials used to manufacture the natural PTFE Tube liner conforms to FDA 21 CFR 177.1550, and the antistatic PTFE liner conforms to FDA 21 CFR 178.3297.

## **3-A SANITARY STANDARDS**

The PTFE used in the liner is manufactured solely from materials which meet the requirements of the 3-A Sanitary Standards.

## **PHARMACEUTICAL MANUFACTURERS' APPROVALS**

Most of the major pharmaceutical manufacturing companies in the world have audited and/or approved Aflex Hose as a Hose Supplier.

## **CE MARKING (EUROPE ONLY)**

Aflex has been assessed by Zurich Risk Services and found to comply with the Pressure Equipment Directive 97/23/EC (European Community) Conformity Assessment Module D1, approved to CE Mark applicable hose products, accompanied by a Hose Usage Data Sheet, and a Declaration of Conformity.

## **ATTESTATIONS OF CONFORMITY TO ATEX DIRECTIVE 94/9/EC (Potentially Explosive Atmospheres)**

Available for hose and assemblies for components used in Gas Zones 1 & 2 and Dust Zones 21 & 22, when applicable.

## **MATERIAL CERTIFICATION TO EN10204**

Available for all the hose or hose assembly components.

## **CERTIFICATES OF CONFORMITY TO BS EN ISO/IEC 17050**

Are available for all products.

## **HOSE IDENTIFICATION AND TESTING**

All Aflex Hose assemblies are identified with a stainless steel identification tag, ring or ferrule, vibro etched with a unique serial number for traceability, and other relevant information.

Each assembly is pressure tested to 1.5 times maximum working pressure before despatch, and pressure test certificates can be supplied.

FOR CERTIFICATION, CONDITIONS OF SALE, HOSE CONFIGURATIONS, ANTISTATIC LINER REQUIREMENT and other information, please contact Aflex Hose, or refer to the relevant section in the Aflex Hose website [www.aflex-hose.com](http://www.aflex-hose.com)



**AFLEX HOSE LTD**  
Spring Bank Industrial Estate  
Watson Mill Lane, Sowerby Bridge  
Halifax, West Yorkshire HX6 3BW  
  
T: 01422 317200 F: 01422 836000  
W: [www.aflex-hose.com](http://www.aflex-hose.com)



**AFLEX HOSE USA, LLC**  
6111 Keller's Church Road, Unit B  
Pipersville, Pennsylvania, PA18947  
  
T: 215 766 1455 F: 215 766 1688  
W: [www.aflex-hose.com](http://www.aflex-hose.com)



Certificate No. 1977