

Cam-Tite®

Top Entry Metal
Ball Valves for
Severe Service
Applications



ITT Industries

Engineered for life

CONTENTS

	Page
Introduction	1
Quality Assurance	2 – 3
Design Features	4 – 5
Seat Options	6 – 7
Ceramic Ball	8
Bonnet Options	8 – 9
Special Services	10
Dry Chlorine Service	11
Special Installations	
Welding Without Disassembly	12
Drain Bosses	12
Extended Stems	12
Handle Options	13
Pressure/Temperature Ratings	14 – 15
Flow Coefficients (Cvs)	16
Valve Operating Torques	17
Actuated Service	18
Actuator Torques	19
Dimensions, Weights, Parts Lists	20 – 25
Actuator Mounting Dimensions	26 – 29
Service Guide	30 – 37
Installation & Maintenance Instructions	38 – 40
Exploded Views	41
Compliance with National Standards	42
Materials Standards	42
Ordering Information & Figure Numbers	43 – 45
Metric Conversion Table	46
Conversion Factors	47
Product Specification Worksheet	48
Terms & Conditions of Sale	Inside Back Cover



INTRODUCTION

Headquartered in Lancaster, PA, ITT Industries Engineered Valves' product line is as extensive as the many industries that we serve. Our 45 year heritage stems from diaphragm valves, of which we are the recognized leader.

Through the years, our product offering has grown extensively. Our corrosion handling expertise has provided the impetus for the design of quarter-turn valve products like our Cam-Tite® Ball Valve.

By developing products such as the Cam-Tite that address specific problems encountered in industry, we continue to expand our commitment to remain a leader in flow control.

The performance of our products is surpassed only by the care taken in the many facets of their manufacturing. Excellence in quality assurance, product reliability, and product safety will always remain of paramount concerns.

Quality Assurance Measures

Every Valve Is Tested

Each and every standard Cam-Tite Ball Valve receives a seat and hydrostatic shell test prior to shipment. In accordance with MSS-SP-72 and ANSI B16.34, this testing includes an 80 psi air under water seat test and a hydrostatic shell test conducted at 1.5 times the cold working pressure (CWP) rating of the valve. Any visible leakage indicated by the above test procedures is cause for rejection. With valves prepared for special services, such as dry chlorine, alternate testing measures have been designed to assure product performance.

As further assurance of valve quality, other testing methods such as mass spectrometer or halogen leak testing are available upon customer request.

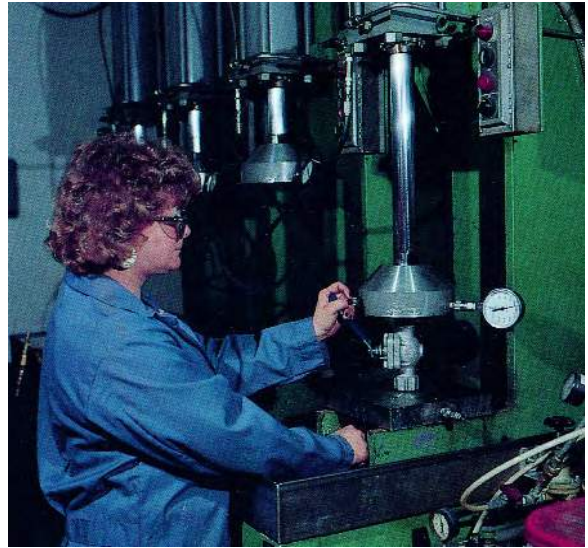

Every Valve Is Inspected

Multiple inspections during the machining of component parts and during assembly insure the high standards of quality for which the Cam-Tite Ball Valve is noted. Final assembly inspection is preceded by various work-in-progress dimensional checks and assembly process inspections.



Every Valve Is Tagged

A computer generated stainless steel tag is affixed to each Cam-Tite Ball Valve, pinned to the body. The first line designates the configuration number, which automatically correlates information unique to the pressure class of the valve; its size; body, seat, and seal materials; and other data specific to the valve.

The second line of the tag contains the original order number which is linked to the production traveler for the valve. This traveler contains information relating to the dates on which the valve was assembled, tested, inspected, and finally shipped.

This tag is important documentation to protect you from field modified or bogus products.

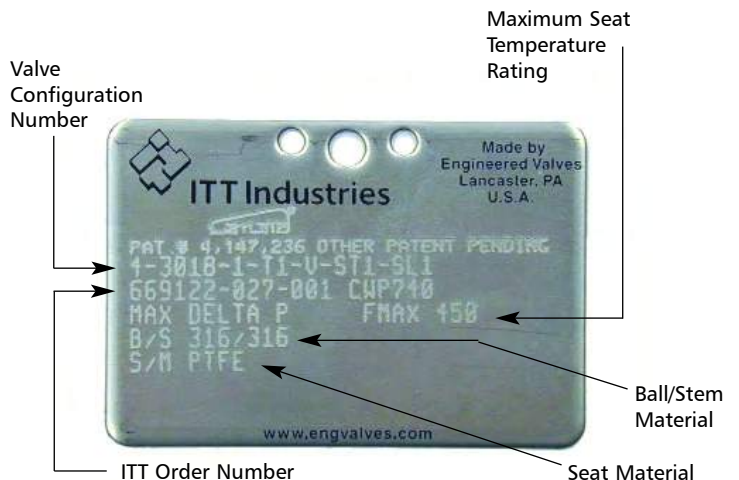

Quality Assurance Measures

Computer Aided Design (CAD)

CAD systems enhance engineering capabilities and streamline the process of product modifications and new product design.



Modernized Production Capabilities

Modern, computer controlled manufacturing equipment, coupled with focused production cells and methods, assure high standards in product quality. These methods also result in speed and flexibility across the entire scheduling and manufacturing cycle.



Radiography

To augment visual inspection, x-ray examination of major castings is utilized for volumetric evaluation. This option is available upon customer request.



Liquid Penetrant Examination

Surface discontinuities in castings can be evaluated through liquid (dye) penetrant evaluations. This quality assurance method is available upon customer request.



Positive Material Identification

Taking the guesswork out of material identification, an alloy analyzer can provide additional verification of the chemical composition of metallic components. Available upon request.



Beveled Edge Ball Design

The Geometry Is The Difference

First introduced in 1979, the Cam-Tite Ball Valve has developed a reputation for performance unequaled by conventional floating ball designs. The difference is in the ball, where around the port edge the spherical surface is cut away, forming a bevel that passes completely around the port opening. This is

one of the most important design features of the Cam-Tite Ball Valve since it is the difference in the effective distance across the beveled surfaces and the distance across the spherical surface that actually energizes the seat when the valve is closed.

Conventional Floating Ball Design

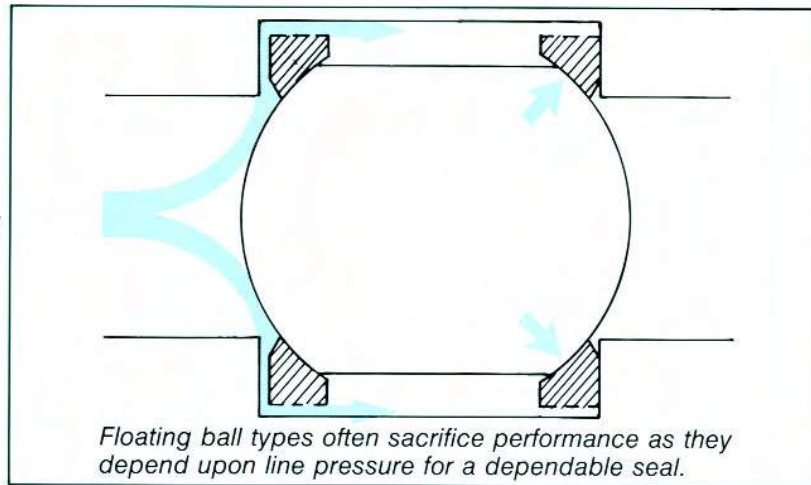

Cam-Tite® Design

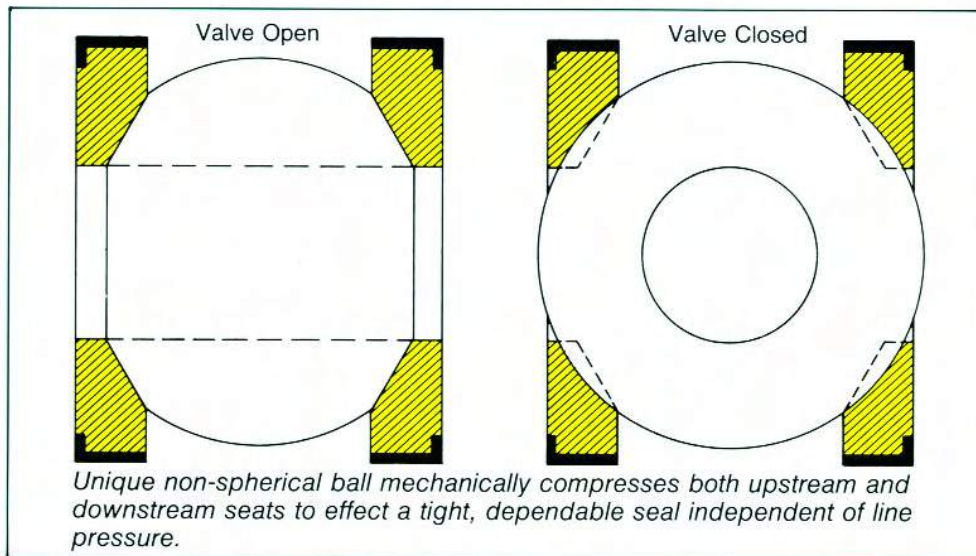

Benefits

- Minimizes pressure on seats to reduce cold flow and extend seat life.
- Eliminates the problem of "breakaway torque" in valves that must rest in the open position for long periods.
- Assures positive sealing regardless of line pressure or pressure differential.
- Eliminates seat damage caused by the leading edge of the ball port cutting into the seat as the ball closes.

Superior Stem Seal Design Low Torque Makes The Difference

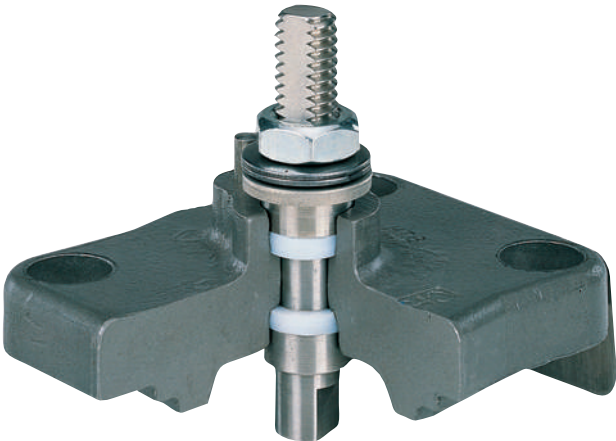

Most stem seals would work well if their only job was to contain the fluid or gas in the piping system. However, stem seals must also serve as bearings and hold the stem in alignment. High operating torques resulting in high lateral loading cause premature stem seal failure in conventional ball and plug valve designs. The Cam-Tite Ball Valve is by design a low torque valve, thereby minimizing lateral loading on the stem seals. In addition, the Cam-Tite stem seals are located further apart, closer to the ends of the stem, reducing the effects of lateral loading.

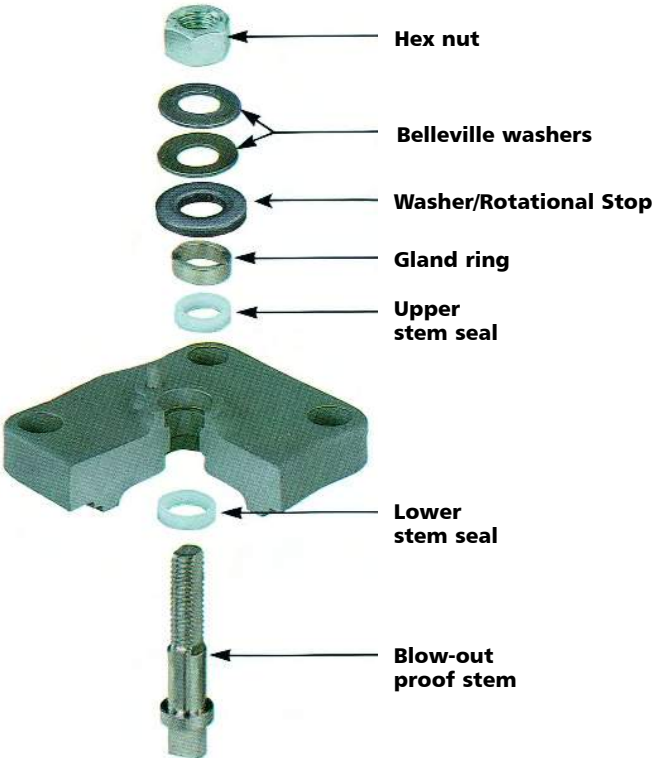

Cam-Tite Ball Valve Seal Assembly Features and Benefits

- Low operating torque reduces lateral loads on stem seals for superior performance.
- Blow-out proof stem with special attention given to surface finish.
- Upper and lower seals provide balanced loading of stem seals
- Standard belleville spring washers provide constant "live load" on stem seals, assuring a tight seal under varying service parameters.

Cam-Tite Seat Design

Refer to pages 14-15 for pressure/temperature data.

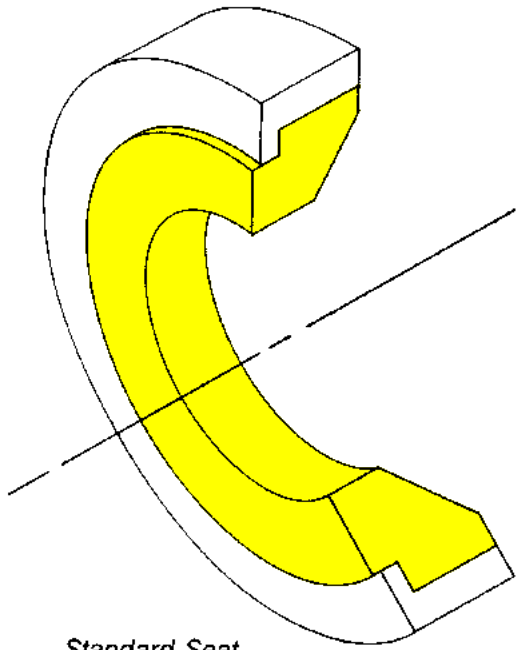

Standard Seat

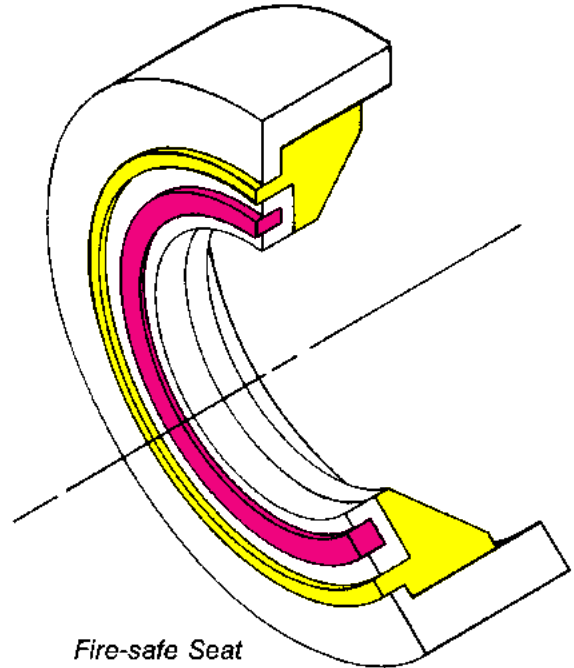

Fire-safe Seat

PTFE Seats and Seals

All standard PTFE seats and seals are manufactured using unfilled, unpigmented PTFE. Virgin PTFE provides excellent resistance to the most aggressive chemicals and can handle media at both elevated and semi cryogenic temperatures. Having no filler material, PTFE components are commonly specified for applications where attack of an added filler could occur. Typical applications would be fluorine based chemicals which would attack glass or highly oxidizing media which would deteriorate graphite. Virgin PTFE is commonly used in Cam-Tite Ball Valves specified for hydrofluoric acid and fluorine gas service. Cam-Tite Ball Valves utilizing virgin PTFE seats and seals have a temperature range of -50°F to 450°F (-45°C to 232°C).

Reinforced PTFE Seats and Seals

For applications that require higher temperature resistance and improved hardness, the Cam-Tite can be supplied with reinforced PTFE (RTFE) seats and stem seals. These components are glass reinforced and offer a temperature

range of -60°F to 520°F (-51°C to 271°C), dependent upon process pressure conditions.

Firesafe Seats and Seals

For applications involving flammable fluids, the Cam-Tite Ball Valve is available with seat and seals designated Firesafe. Most commonly supplied as reinforced PTFE, Firesafe seats incorporate secondary metal-to-metal seat rings and a special back seal for normal seat operation. Stem seals combine the fire resistance of graphite with a reinforced PTFE bearing. Cam-Tite Ball Valves equipped with these components meet the requirements of API 607 (3rd or 4th edition depending on valve configuration).

UHMWP Seat and Seal Components

Ultrahigh molecular weight (high density) polyethylene offers abrasion resistance and wear resistance far superior to that of PTFE. Seats and seals of UHMWP provide exceptional service in high cycle applications. The material has a practical temperature limit of 200 degrees F (93°C).

PEEK Seat and Seal Components

PEEK is a tough high temperature engineered thermoplastic offering broad chemical resistance, excellent recovery from deformation, a high degree of dimensional stability, and exceptional resistance to hydrolysis. PEEK has outstanding abrasion resistance and is not sensitive to dynamic fatigue.



G2000 PEEK

Chemical

Since G2000 PEEK is a virgin crystalline polymer, its resistance to chemical attack is excellent. G2000 PEEK is recommended for most environments other than strong oxidizers. It is compatible with numerous acids, bases, and aliphatic and aromatic hydrocarbons.

Steam

Unlike most thermoplastics, G2000 PEEK will not hydrolize and is recommended for use in steam service and other high-temperature aqueous processes.

Nuclear

G2000 PEEK offers excellent resistance to embrittlement when exposed to gamma radiation. This resistance is maintained in both acid and alkali media.

G3000 PEEK

G3000 PEEK combines the basic properties of the G2000 PEEK with that of carbon graphite and PTFE fillers, yielding a seating material with greater stability at higher temperatures and significantly reduced seating torque. Due to its filled content, G3000 PEEK is an excellent choice for high temperature applications, having a maximum temperature capability of 550°F (288°C).

Table 1

Comparison of typical physical properties

Property	G3000 PEEK	G2000 PEEK	PTFE	PTFE Filled
Specific Gravity	1.48	1.32	2.20	2.19
Hardness (Shore) ▲	D85	D85	D50-55	D50-60
Tensile Strength (psi)	17,000	14,500	4000	2000
Tensile Elongation(%)	5	35	300	200
Flexural Strength (psi)	30,500	16,000	No break	-
Flexural Modulus (psi)	1.45M	550,000	90,000-100,000	-
Shear Strength (psi)				
@ 100F	-	12,000	2800	3400
@ 200F	-	11,000	1900	2750
@ 300F	7,750	9,000	1700	2500
@ 400F	-	6,500	-	-
@ 500F	-	3,800	-	-
Impact Strength				
Notched IZOD	9	1.6	-	2.7
Tensile (ft-lbs/in)	-	-	30-200	-

▲ Rockwell "D" Scale

Ceramic Ball

The Cam-Tite ceramic ball is an advanced engineering oxide ceramic, magnesia-partially stabilized zirconia (Mg-PSZ) which has extremely high strength and fracture toughness.

Features:

- Corrosion resistant*
- Impervious to gases
- Impact resistant
- Withstands high temperature
- High thermal shock resistance
- Impervious to build-up on the ball
- Excellent choice where ferric chloride build-up is a problem



The ceramic ball can be used with any combination of the available stem and body materials for the Cam-Tite Ball Valve.

Caged Bonnet Option

The patented “Caged Bonnet” was specifically designed to meet the needs of those hazardous applications where a quick and easy turnaround during scheduled maintenance is required. The uniquely designed caged bonnet assembly allows the repair and replacement of all internal components simply by removing the bonnet bolts and lifting off the bonnet assembly.

The caged device is available on all bonnet configurations (standard, extended, severe service and bellows) in both nuclear and commercial configurations. The device utilizes a captured (caged) metal saddle that holds the ball, seat rings, seats, grounding springs and cover gasket (nuclear model only) in place. This device allows the removal and replacement of all components utilizing one subassembly.



*Caged bonnet shown on a standard bonnet
U.S. Patent 5, 152,502*

*Consult factory for specific applications.

Bonnet Options



Extended Bonnet

Cam-Tite Ball Valves can be furnished with extended bonnets for higher temperature or semi-cryogenic services. The extended bonnet allows the valve to be wrapped with insulation without interference from the hand lever and is interchangeable with the standard bonnet. This arrangement raises the stem seal further away from the flowing fluid, thereby reducing the effects of the temperature extremes. The stem is supported to minimize the possibility of galling or stem leakage. The extended bonnet permits the packing nut to extend beyond the valve insulation, thereby permitting stem seal adjustment without disturbing the insulation.



Severe Service Bonnet

The severe service bonnet option was specifically designed to meet the needs of those difficult applications where a true stuffing box is preferred. This design utilizes the extended bonnet as the primary component maintaining the conventional bottom stem seal, augmented by stacked Chevron V-ring packing at the top. The addition of an optional lantern ring and bonnet tap provides for the insertion of compatible lubricants into the packing, inert gas padding, or leak detection. Available in ANSI Class 150 through 600, the severe service bonnet option brings a modular approach to the stem sealing system of the Cam-Tite Ball Valve.



Bellows Stem Seal

Cam-Tite Ball Valves are also available with a bellows stem seal. This stem seal device, manufactured by Kerotest Manufacturing Corp., provides a hermetic stem seal via a unique quarter-turn bellows design.

The interface design for the bellows stem seal to the Cam-Tite Ball Valve was a joint effort between Engineered Valves and Kerotest in which the bellows assembly becomes integral to the bonnet of the valve. This allows for disassembly should replacement of internal components be required. The device can also be easily actuated. Bellows stem seals are available in ANSI Class 150 and 300 in a variety of materials.

The Trusted Name For Severe Services

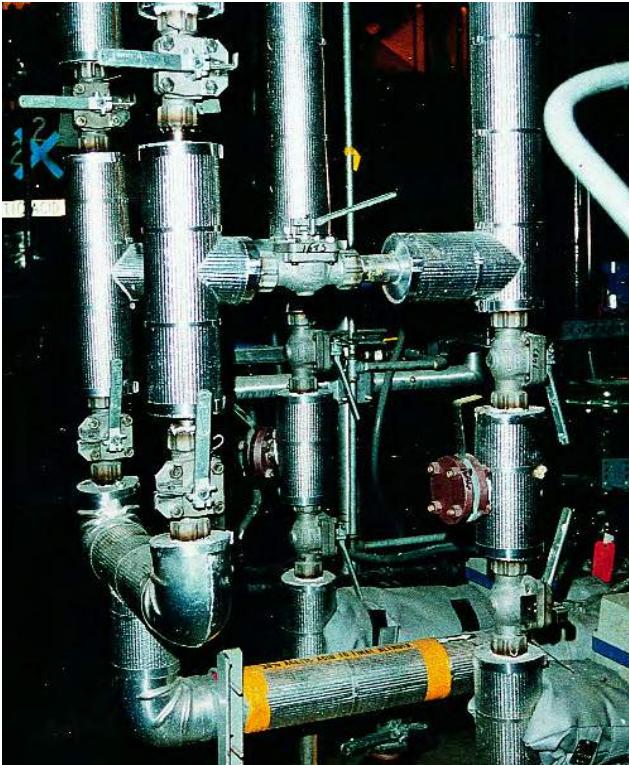

Since 1979 the Cam-Tite Ball Valve has become a performance leader in tough-to-handle services. The combination of the patented sealing arrangement and the superior stem seal design has ushered the Cam-Tite into services where its design superiority has proven itself over plug valves and conventional floating ball type valves. Among the services where Cam-Tite Ball Valves have emerged as the solution are the following:

- Dry Chlorine
- Phosgene
- Anhydrous HF
- Anhydrous Ammonia
- Anhydrous HCL
- High Vacuum
- PCL₃
- Steam
- VOC_s

Anhydrous HF Acid Service

Numerous years of field application experience has lead to a recommended construction for Cam-Tite Ball Valves in anhydrous hydrofluoric acid. With a variety of body materials to choose from, valves prepared for HF service normally incorporate inconel 600 bonnet bolting,

inconel 718 belleville washers, a stainless steel rotational stop (in applicable sizes), and virgin PTFE seats and seals. Additionally, all HF valves are specially assembled, cleaned, and tested. Specify "Prepared for HF Service" using code "HF" in the valve configuration number.

Oxygen Service

Cam-Tite Ball Valves can be prepared for oxygen service. These valves are subjected to rigid procedures to insure that they are free from all burrs, chips, and dirt. They are specially assembled, cleaned, tested and packaged.

Valves prepared for oxygen are lubricated with DuPont Krytox® GPL 206 unless otherwise specified. Order valves "Prepared for Oxygen Service" using "OX" in the configuration number.

Vacuum Service

The Standard Cam-Tite Ball Valve is suitable for vacuum services down to 20 microns absolute. For vacuum conditions below 20 microns absolute high vacuum valves can be supplied. High vacuum service valves are manufactured with special attention to seat and seal tolerances and finishes and are specially cleaned and packaged. These valves have

leakage rates less than 1×10^{-7} STD. CC/Sec as verified by a mass spectrometer test. Specify valves "Prepared for High Vacuum Service" using code "VAC" in the configuration number.

See pages 43-45 for additional ordering information for Cam-Tite Ball Valves prepared for the above special services.

The Proven Leader in Dry Chlorine

In dry chlorine service, valves must be capable of absolute shutoff while maintaining piping system integrity (no stem seal leakage). For cost-effectiveness, they must also offer long service life. Simple enough, yet the punishing nature of chlorine handling has defeated many types of chlorine valves and forced users to accept compromises in performance and safety.

Such compromises are no longer necessary. Thousands of installed Cam-Tite valves are demonstrating their superiority, based on three important features:

- Patented Ball Design – Assures zero leakage through the valve.
- Superior Stem Seals – Prevents leakage to the atmosphere.
- Positive Valve Body Vent

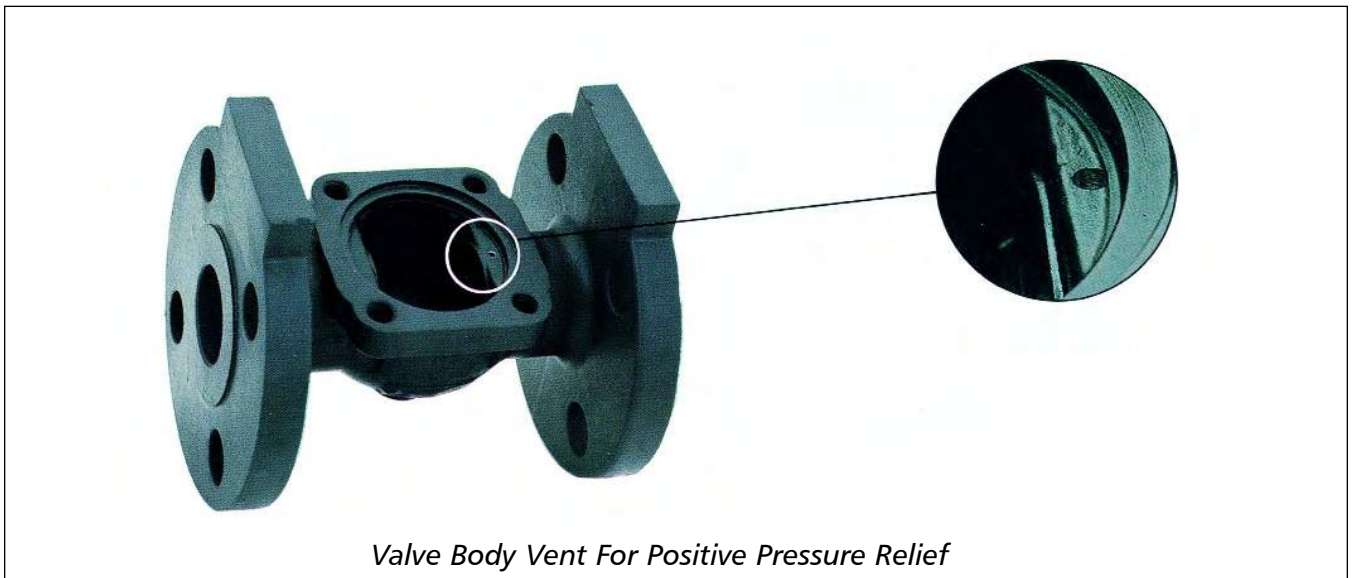

Positive Relief

In accordance with the Chlorine Institute Pamphlet No. 6, all dry chlorine ball valves must be equipped to relieve excess pressure in the ball cavity toward the direction of high pressure. This is an important safety feature, ensuring that excess pressure in a closed valve will bleed off harmlessly. Cam-Tite Ball Valves prepared for dry chlorine service are equipped with a positive vent in the valve body as opposed to competitive designs that rely on self-relieving seats or vents through the ball or plug. Experience has proven that self-relieving seats do not provide predictable performance. Placing the vent in the body eliminates the possibility of installing a vented ball or plug backwards. A positive body vent is the only way to provide predictable, repeatable safety relief.

Note: Cam-Tite Ball Valves supplied with vented bodies are considered unidirectional with regards to shut-off.

Chlorine Valve Preparation

Preparation in accordance with the Chlorine Institute Pamphlet 6 includes:

- A relief vent in the body to bypass the upstream seat.
- A cast arrow on the body to indicate the direction of pressure tightness.
- Special cleaning of all valve components.
- Special testing for seat tightness and relief port venting.
- Special packaging and marking.

Cam-Tite Ball Valves for dry chlorine service are usually supplied with cast carbon steel (ASTM A216 Gr. WCB) bodies, monel ball and stem, and reinforced PTFE seats, seals and cover gasket. Other materials, including alloy 20, hastelloy, and ceramic are commonly used in chlorine services and are available as required.

When ordering valves "Prepared for Dry Chlorine Service", specify code "CLV" in the configuration number.

Welding Without Disassembly

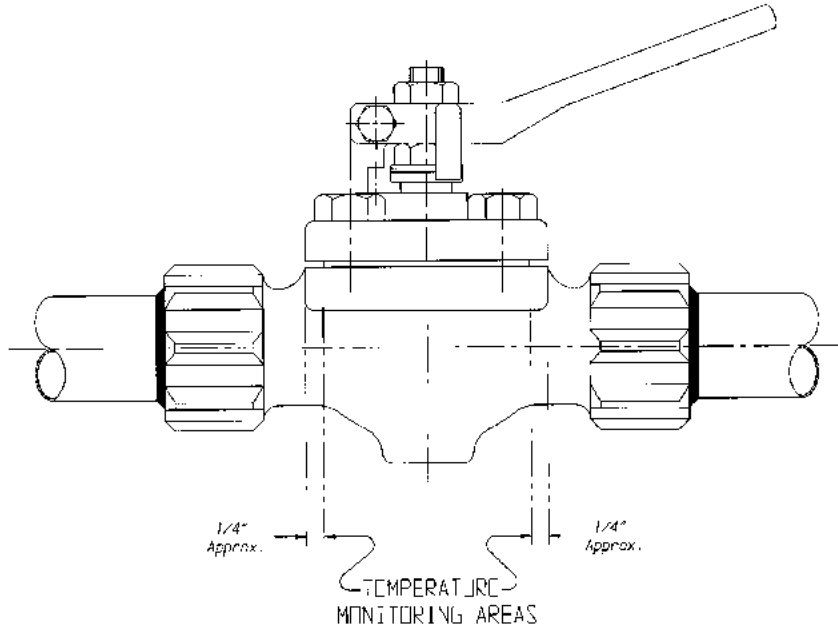

Cam-Tite Ball Valves can be welded into the pipeline without disassembly provided certain procedures and precautions are followed. The valve must be in the open position during welding and should remain open until it cools to ambient temperature. Welding procedures in accordance with Section IX of the ASME Boiler and Pressure Vessel Code should be utilized. In addition, a Tempilstik (350 degrees F for PTFE and RTFE seats and seals or 200 degrees F for UHMWP seats and seals) must be used to monitor the temperature at the seat/gasket area. This is the area in line with

the body/cover flange as shown above. Welding should be controlled such that the maximum temperature in this area remains below that of the rated Tempilstik. A tremendous amount of time and trouble associated with the dismantling and reassembly of welded valves is avoided, but more importantly, the integrity of the factory hydrostatic and seat testing is maintained when following these procedures. See page 42 for weld end machining standards.

Drilled, Tapped And Plugged Drain Bosses

All Cam-Tite Ball Valves have an integrally cast drain boss on the bottom side of the body. This drain boss can be drilled, tapped, and plugged if draining of the valve cavity is required. The standard drilling is 1/4" NPT on 1/2" through 2" sizes and 1/2" NPT on 3" through 6" sizes. Carbon steel valves are furnished with ASTM

A193 GR B7 plugs while stainless steel valves are furnished with ASTM A193 GR B8 plugs. (Consult the factory for specifications of drain plugs supplied on other body materials.) Specify valves "Prepared with Tapped and Plugged Drain Port" using code "D" in the configuration number when ordering.

Stem Extensions

The Cam-Tite Ball Valve can be supplied with a variety of designs to support applications which require extended stems. Stem extensions can be provided in carbon steel and stainless steel materials of construction and can be spec

ified in a wide range of lengths for complete versatility.

See pages 43-45 for information on ordering stem extensions for Cam-Tite valves.

Oval Safety Handwheels

Oval safety handwheels are available on Cam-Tite Ball Valves 1/2" through 2". These handwheels are used where the standard hand levers could be accidentally bumped open or closed. The oval safety handwheels are either cast carbon steel or cast stainless steel. The

oval shape provides quick, easy identification of valve position. Specify "Prepared with Oval Safety Handwheel" using code "HD2" (carbon steel) or code "HD3" (stainless steel) in the configuration number.

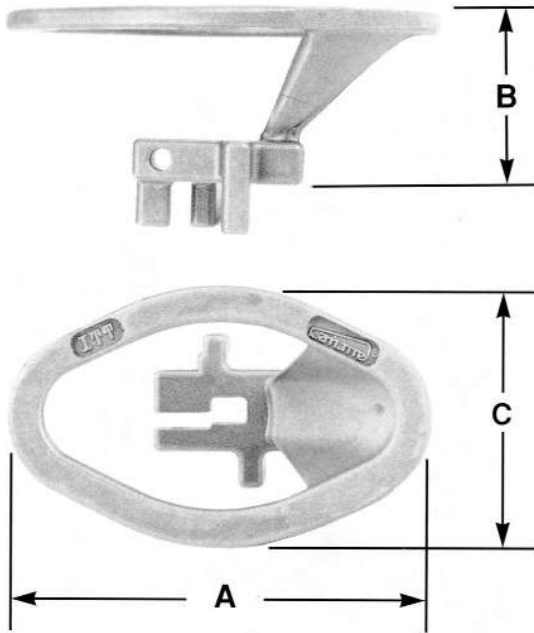

DIMENSIONS (INCH)

Valve Size	A	B	C
1/2" - 1"	5.0	2.03	3.0
1 1/2"	6.5	2.03	4.0
2"	6.5	2.03	4.0

DIMENSIONS (MM)

1/2" - 1"	127	52	76
1 1/2"	165	52	102
2"	165	52	102

Spring Return Handle Options

The Cam-Tite Ball Valve can be supplied with either a manual spring return handle (dead man's handle) or a fire-safe fusible linked spring return handle for safety shut-off of manually operated valves.

Chain Operator Options

The Cam-Tite Ball Valve can be provided with a T-handle and chain for operation in services where access to the valve is limited. The T-handle operator can be supplied for installation in either vertical or horizontal pipelines and is available in both carbon steel and stainless steel construction.

Lock Out Device Option

OSHA 1910.147 requires that valves in certain applications have a method of being locked out in the closed position to prevent unauthorized opening. The Cam-Tite Ball Valve can be supplied with a locking device which will lock the valve in either the open or closed position. The standard locking device is constructed of stainless steel and can be provided on any of the optional bonnet designs. Specify "Prepared with Locking Device" using code "LDS" in the configuration number for the valve.

See pages 43-45 for additional ordering instructions for Cam-Tite valves prepared with the above handle options.

Pressure/Temperature Ratings

Class 150 Flanged, Butt Weld

Cold Working Pressure (PSIG)	
Carbon Steel – WCB	285
Stainless Steel – CF8M, CF3M	275
Alloy 20 – CN7M	230
Monel M-35-1	230
Hastelloy CW-6M	290
Titanium – B367 Gr C3	265

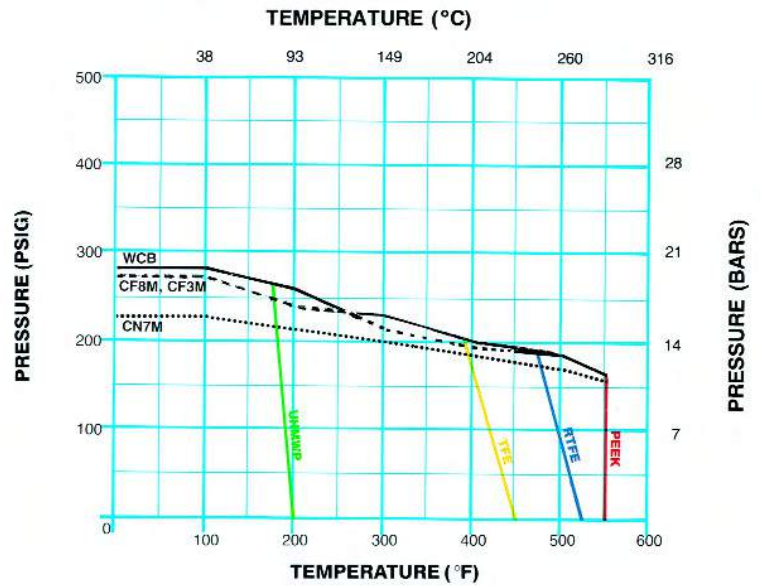

Class 150-300 Screwed, Socket Weld Class 300 Flanged, Butt Weld

Cold Working Pressure (PSIG)	
Carbon Steel – WCB	740
Stainless Steel – CF8M, CF3M	720
Alloy 20 – CN7M	600
Monel M-35-1	600
Hastelloy CW-6M	750
Titanium – B367 Gr C3	695

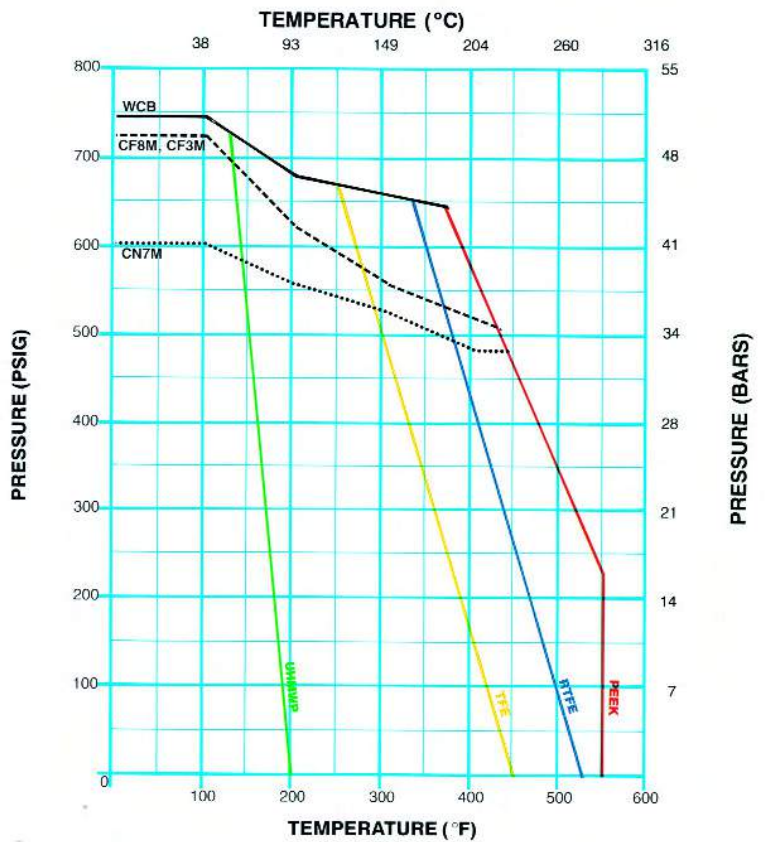

Pressure/Temperature Ratings

Class 600 Flanged, Butt Weld Screwed, Socket Weld

Cold Working Pressure (PSIG)	
Carbon Steel – WCB	1480
Stainless Steel – CF8M, CF3M	1440
Alloy 20 – CN7M	1200
Monel M-35-1	1200
Hastelloy CW-6M	1500
Titanium – B367 Gr C3	1390

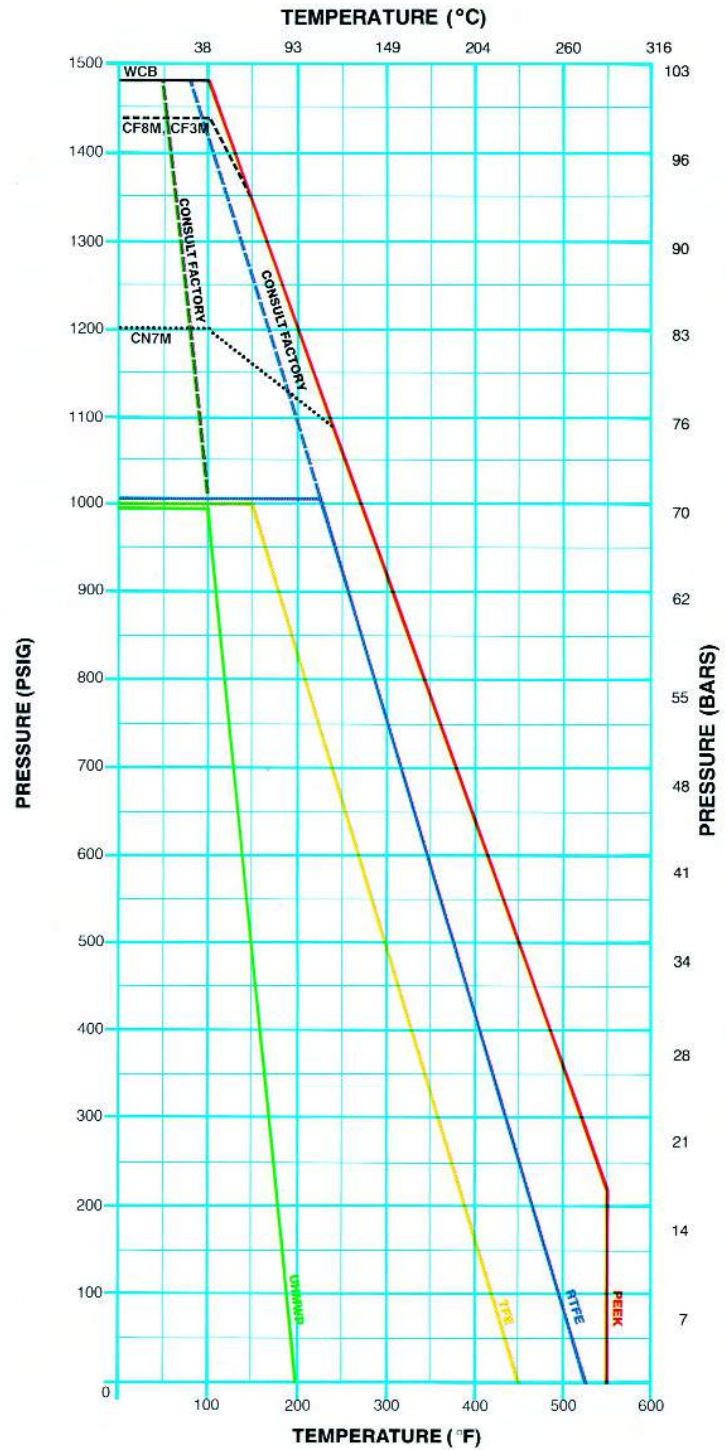

Note: Consult factory for pressure/temperature recommendations for 3" and larger Class 600 fire-safe seats.

Flow Coefficients (Cv)

Cv = Flow of water in U.S. gallons per minute through the valve with a one psi pressure drop.

Class 150 Flanged and Butt Weld

Degrees Open From Closed	10°	20°	30°	40°	50°	60°	70°	80°	90°
1/2"	–	–	0.1	0.3	0.9	1.4	2.2	3.5	8.4
3/4"	–	–	0.2	1.2	2.2	3.7	5.4	8.0	17.0
1"	–	–	0.2	1.1	2.5	4.6	7.6	12.8	30.0
1 1/2"	–	–	1.0	3.0	5.5	11.0	17.5	33.5	73.0
2"	–	0.5	3.0	6.5	11.5	21.0	39.0	81.5	160.5
3"	–	0.5	3.7	12.4	22.9	42.4	81.5	181.0	355.0
4"	–	1.1	7.8	26.1	48.4	89.7	172.5	383.4	751.6
6"	–	–	–	–	–	–	–	–	1500

Class 300 Flanged and Butt Weld

Degrees Open From Closed	10°	20°	30°	40°	50°	60°	70°	80°	90°
1/2"	–	–	0.1	0.3	0.7	1.2	2.1	3.8	8.4
3/4"	–	–	0.2	0.8	1.6	2.8	5.0	9.5	18.2
1"	–	–	0.2	1.0	2.4	4.6	8.0	15.6	31.6
1 1/2"	–	1.0	2.5	5.5	10.0	17.5	29.0	51.0	80.0
2"	–	1.0	3.0	6.5	13.5	22.0	39.0	72.0	163.0
3"	–	2.5	8.4	17.9	34.5	57.5	99.2	180.3	360.5
4"	–	5.3	17.8	37.9	73.0	121.7	209.9	381.6	763.3
6"	–	–	–	–	–	–	–	–	1500

Class 600 Flanged and Butt Weld

Degrees Open From Closed	10°	20°	30°	40°	50°	60°	70°	80°	90°
1/2"	–	–	0.1	0.3	0.8	1.3	2.2	3.5	8.5
3/4"	–	–	0.2	0.9	1.9	3.4	5.6	8.2	17.0
1"	–	–	0.2	0.8	1.9	3.8	7.0	14.2	28.4
1 1/2"	–	–	0.5	3.5	9.5	17.0	31.0	55.0	81.0
2"	–	0.9	3.0	6.0	11.5	21.0	39.0	87.0	163.0
3"	–	1.4	4.7	11.2	28.1	51.1	94.6	197.1	365.0
4"	–	2.9	9.9	23.6	59.1	107.4	198.9	414.5	767.5

Screwed and Socket Weld – All Classes

Degrees Open From Closed	10°	20°	30°	40°	50°	60°	70°	80°	90°
1/2"	–	–	0.1	0.2	0.7	1.2	2.1	3.6	8.4
3/4"	–	–	0.2	0.7	1.6	2.9	5.0	8.5	17.0
1"	–	–	0.5	0.7	2.0	3.8	6.8	12.5	30.8
1 1/2"	–	1.0	2.5	5.0	9.5	15.5	24.5	45.0	78.4
2"	–	1.0	3.0	6.0	11.5	21.0	38.5	76.5	158.5
3"	–	2.9	8.4	16.8	32.3	53.9	96.3	181.7	349.5

Note: Consult factory for recommendations on valves intended for throttling or modulating services.

Valve Operating Torques

The actual amount of torque required to operate a valve is dependent upon many variables, such as line pressure, temperature, type of fluid, and frequency of operation. The following tables are based on the maximum break-away/closing

torque requirements of a Cam-Tite Ball Valve handling a clean, particle free liquid. For valves used in heavy liquids, high particulate fluids, gases, or sub zero temperatures, consult the factory for actual torque recommendations.

UNFILLED PTFE

PRESSURE DROP ACROSS VALVE			
SIZE	275 PSIG	740 PSIG	1000 PSIG
1/2", 3/4", 1"	75 in-lb	75 in-lb	75 in-lb
1 1/2"	85 in-lb	85 in-lb	85 in-lb
2"	175 in-lb	175 in-lb	175 in-lb
3"	435 in-lb	435 in-lb	450 in-lb
4"	525 in-lb	770 in-lb	925 in-lb
6"	1270 in-lb	1615 in-lb	N/A

FIRESAFE REINFORCED PTFE

PRESSURE DROP ACROSS VALVE			
SIZE	275 PSIG	740 PSIG	1000 PSIG
1/2", 3/4", 1"	115 in-lb	115 in-lb	115 in-lb
1 1/2"	150 in-lb	150 in-lb	160 in-lb
2"	325 in-lb	325 in-lb	350 in-lb
3"	735 in-lb	750 in-lb	1700 in-lb
4"	890 in-lb	1545 in-lb	2535 in-lb
6"	2300 in-lb	2650 in-lb	N/A

REINFORCED PTFE (RTFE)

PRESSURE DROP ACROSS VALVE			
SIZE	275 PSIG	740 PSIG	1000 PSIG
1/2", 3/4", 1"	105 in-lb	105 in-lb	105 in-lb
1 1/2"	110 in-lb	110 in-lb	110 in-lb
2"	220 in-lb	220 in-lb	235 in-lb
3"	590 in-lb	590 in-lb	640 in-lb
4"	695 in-lb	895 in-lb	1195 in-lb
6"	1355 in-lb	1730 in-lb	N/A

UHMW POLYETHYLENE

PRESSURE DROP ACROSS VALVE			
SIZE	275 PSIG	740 PSIG	1000 PSIG
1/2", 3/4", 1"	95 in-lb	95 in-lb	95 in-lb
1 1/2"	120 in-lb	120 in-lb	120 in-lb
2"	260 in-lb	260 in-lb	260 in-lb
3"	620 in-lb	620 in-lb	785 in-lb
4"	795 in-lb	795 in-lb	1080 in-lb
6"	1555 in-lb	1555 in-lb	N/A

G3000 PEEK

PRESSURE DROP ACROSS VALVE			
SIZE	275 PSIG	740 PSIG	1480 PSIG
1/2", 3/4", 1"	195 in-lb	195 in-lb	195 in-lb
1 1/2"	240 in-lb	265 in-lb	265 in-lb
2"	340 in-lb	375 in-lb	695 in-lb
3"	1285 in-lb	1345 in-lb	1705 in-lb
4"	1400 in-lb	1610 in-lb	2665 in-lb
6"	N/A	N/A	N/A

G2000 PEEK

PRESSURE DROP ACROSS VALVE			
SIZE	275 PSIG	740 PSIG	1480 PSIG
1/2", 3/4", 1"	195 in-lb	195 in-lb	195 in-lb
1 1/2"	250 in-lb	250 in-lb	250 in-lb
2"	375 in-lb	555 in-lb	960 in-lb
3"	1400 in-lb	1595 in-lb	2500 in-lb
4"	2055 in-lb	2775 in-lb	3960 in-lb
6"	N/A	N/A	N/A

Maximum Allowable Stem Torques

The following torque values represent the maximum allowable torque which can be applied to a specific valve size and stem material before permanent damage to the stem occurs. These values should not be exceeded when sizing power actuators for application with the Cam-Tite Ball Valve.

STEM MATERIAL					
SIZE	316 ss	Monel	Alloy 20	Hastelloy 276	Inconel 625
1/2" - 1"	460 in-lb	390 in-lb	275 in-lb	275 in-lb	275 in-lb
1 1/2"	590 in-lb	505 in-lb	355 in-lb	355 in-lb	355 in-lb
2"	1040 in-lb	1110 in-lb	785 in-lb	785 in-lb	785 in-lb
3"	4660 in-lb	4300 in-lb	2510 in-lb	2940 in-lb	4300 in-lb
4"	4800 in-lb	5760 in-lb	3360 in-lb	3940 in-lb	5760 in-lb
6"	14500 in-lb	29100 in-lb	17000 in-lb	19900 in-lb	29100 in-lb

Consult factory for stem materials not listed above.

Actuated Service

By virtue of its low torque design, the Cam-Tite Ball Valve is an inexpensive and easy valve to actuate. The low torque feature allows the valve to be actuated with a much smaller and more cost effective actuator. This means you have the superior performance of the Cam-Tite Ball Valve at a lower package cost than with conventional ball or plug valves.

When it comes to actuated "isolation" valves, the Cam-Tite is truly unique. To begin with, since there is virtually no load on the seats when the valve rests in the open position, the seats remain in prime condition waiting to be called into service. Since there is no "breakaway" when moving from the open to closed positions, the actuator is set into motion without opposing load. Only when the valve is essentially closed does the valve operating torque reach design peak. It is nice to know that when peak load is reached, the valve is already closed.



Engineered Valves can supply actuator packages utilizing the Compact rack and pinion actuator or any other actuator suited to your needs. Actuator packages are completely assembled and tested by Engineered Valves to meet our highest standards of quality.

Typical actuator mounting is accomplished either by utilizing the flange pads on flanged end valves or by replacing the cover bolts with studs and double nuts on socket, threaded and butt-weld configurations. Both methods allow the removal of the actuator without disturbing the body/cover seal.

If field mounting of actuation is necessary, the following guidelines should be followed:

1. Use flange pad mounting when available. If not, then machined studs must be used – not threaded rod.
2. It is recommended that if the bonnet is loosened, then the cover gasket should be replaced.
3. Bolting torques shown on page 40 should be followed.
4. The rotational stop pin in the cover (3", 4" and 6") should be removed. Open/closed positioning should be accomplished by proper adjustment of the actuator travel stops.

See pages 26-29 for actuator mounting details.



Actuator Output Torques (in-lb)

Double Acting

1A – Inner spring (H15 only)
1B – Outer spring (H15 only)
2 – Two springs (H15 only)
2A – Inner and middle springs
2B – Inner and outer springs
2C – Middle and outer springs
3 – All three springs

ACTUATOR SIZE	OPERATING PRESSURE (PSI)					
	20	40	60	80	100	120
15	39	79	119	160	199	239
20	79	158	238	318	398	478
25	160	320	480	640	800	960
30	267	537	806	1074	1343	1611
35	471	941	1412	1882	2353	2824
45	907	1813	2719	3626	4532	5438
60	2149	4298	6446	8595	10744	12893
75	3765	7530	11295	15060	18825	22590

ACTUATOR SIZE	No. OF SPRINGS	OPERATING PRESSURE (PSI)										SPRING TORQUE	
		40		60		80		100		120		MAXIMUM	
		AIR START	AIR END	AIR START	AIR END	AIR START	AIR END	AIR START	AIR END	AIR START	AIR END	SPRG START	SPRG END
15	1A	53	26	92	64	133	103	171	140	210	178	49	24
	1B			69	18	109	56	147	93	186	131	96	48
	2					85	8	123	45	162	83	144	72
20	2A	78	27	158	104	244	187	322	262	411	339	115	68
	2B			129	55	215	138	293	214	381	290	164	97
	2C					191	97	269	173	358	249	205	121
	3					165	60	243	136	331	212	242	147
25	2A	169	46	331	200	502	366	659	518	816	670	242	128
	2B			278	98	449	264	606	416	763	568	344	178
	2C					419	207	576	359	733	511	401	208
	3					371	116	528	268	685	420	492	256
30	2A	284	92	556	351	847	629	1106	885	1369	1139	391	210
	2B			486	221	773	499	1036	755	1299	1009	521	280
	2C					703	369	966	625	1229	879	651	350
	3					634	239	897	495	1160	749	781	419
35	2A	487	86	962	538	1465	1027	1927	1474	2388	1922	761	379
	2B			836	284	1339	773	1801	1220	2262	1668	1015	505
	2C					1212	520	1674	967	2135	1415	1268	632
	3					1068	266	1548	713	2009	1161	1522	758
45	2A	913	115	1828	985	2798	1929	3686	2789	4574	3650	1516	755
	2B			1576	482	2546	1425	3434	2285	4322	3146	2020	1007
	2C					2295	919	3183	1779	4071	2640	2526	1258
	3					2043	414	2931	1274	3819	2135	3031	1510
60	2A	2261	437	4431	2499	6730	4734	8836	6776	10942	8817	3431	1693
	2B			3867	1355	6166	3590	8272	5632	10378	7673	4575	2257
	2C					5602	2447	7708	4489	9814	6530	5718	2821
	3					5040	1303	7146	3345	9252	5386	6862	3383
75	2A	3869	927	7332	4538	11700	8454	15390	12031	19079	15607	5853	3059
	2B			6313	2585	10681	6501	14371	10078	18060	13655	7806	4078
	2C					9661	4552	13351	8129	17040	11706	9755	5098
	3					8642	2600	12332	6177	16021	9754	11707	6117

Dimensions, Weights, & Parts Lists

1/2" - 2" Valves

Flanged Body

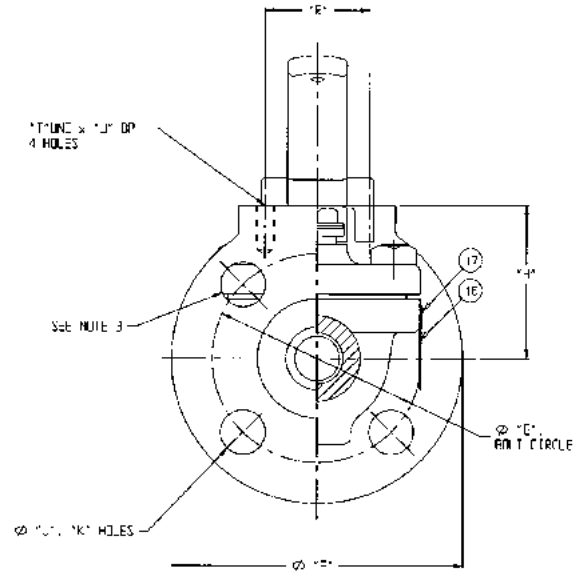
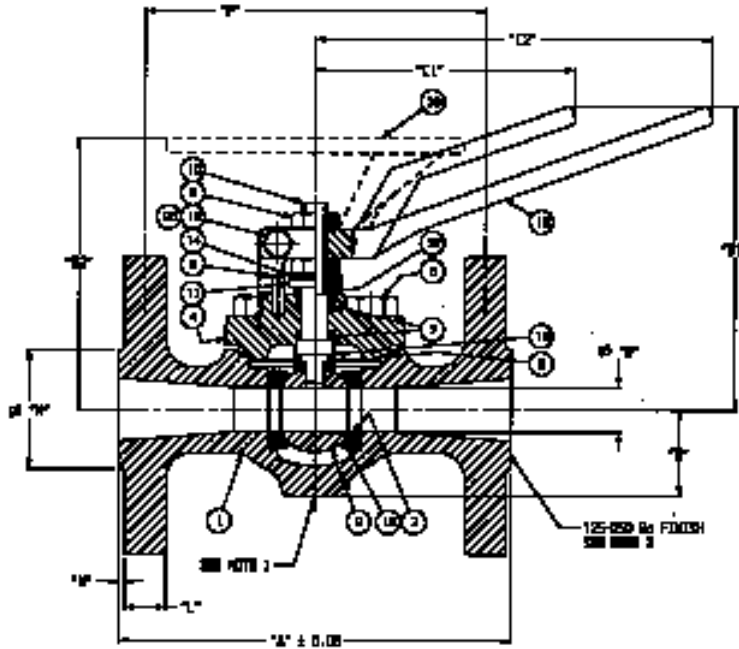

Socket Weld & Threaded Body

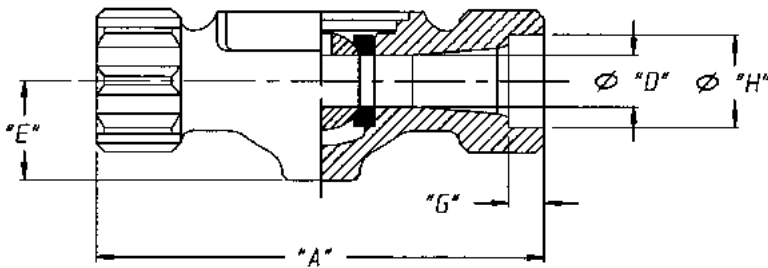

NOTE:

1. Body boss can be drilled, tapped, and plugged.
2. End machining meets ANSI B16.5 for flanged ends.
3. 1/2" & 3/4" 150 lb. class flanged bolt holes are tapped 1/2"-13 UNC class 2B. Top two holes are blind drilled and tapped.
4. The design meets ANSI B16.34, MSS-SP 72 & ANSI B16.10.
5. Valve is shown in the open position. Clockwise rotation of stem closes the valve.

Butt Weld Body

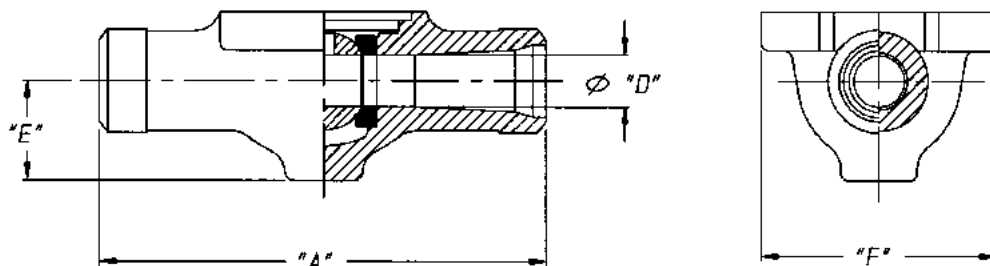

Flanged Body

VALVE SIZE	PRESSURE CLASS	1/4" DIM.	1/2" DIM.	3/4" DIM.	1" DIM.	1 1/2" DIM.	2" DIM.	2 1/2" DIM.	3" DIM.	4" DIM.	5" DIM.	6" DIM.	8" DIM.	10" DIM.	12" DIM.	14" DIM.	16" DIM.	18" DIM.	20" DIM.	WEIGHT LBS	KG
1/2"	500	0.50 (12.70)	0.50 (12.70)	0.50 (12.70)	0.50 (12.70)	0.50 (12.70)	0.50 (12.70)	0.50 (12.70)	0.50 (12.70)	0.50 (12.70)	0.50 (12.70)	0.50 (12.70)	0.50 (12.70)	0.50 (12.70)	0.50 (12.70)	0.50 (12.70)	0.50 (12.70)	0.50 (12.70)	0.50 (12.70)	0.50 (12.70)	0.50 (12.70)
	300	0.50 (12.70)	0.50 (12.70)	0.50 (12.70)	0.50 (12.70)	0.50 (12.70)	0.50 (12.70)	0.50 (12.70)	0.50 (12.70)	0.50 (12.70)	0.50 (12.70)	0.50 (12.70)	0.50 (12.70)	0.50 (12.70)	0.50 (12.70)	0.50 (12.70)	0.50 (12.70)	0.50 (12.70)	0.50 (12.70)	0.50 (12.70)	0.50 (12.70)
	150	0.50 (12.70)	0.50 (12.70)	0.50 (12.70)	0.50 (12.70)	0.50 (12.70)	0.50 (12.70)	0.50 (12.70)	0.50 (12.70)	0.50 (12.70)	0.50 (12.70)	0.50 (12.70)	0.50 (12.70)	0.50 (12.70)	0.50 (12.70)	0.50 (12.70)	0.50 (12.70)	0.50 (12.70)	0.50 (12.70)	0.50 (12.70)	0.50 (12.70)

Dimensions in parenthesis () are millimeters.

Socket Weld & Threaded Body

VALVE SIZE	PRESSURE CLASS	1/4" DIM.	1/2" DIM.	3/4" DIM.	1" DIM.	1 1/2" DIM.	2" DIM.	2 1/2" DIM.	3" DIM.	4" DIM.	5" DIM.	6" DIM.	8" DIM.	10" DIM.	12" DIM.	14" DIM.	16" DIM.	18" DIM.	20" DIM.	WEIGHT LBS	KG
1/2"	500	0.50 (12.70)	0.50 (12.70)	0.50 (12.70)	0.50 (12.70)	0.50 (12.70)	0.50 (12.70)	0.50 (12.70)	0.50 (12.70)	0.50 (12.70)	0.50 (12.70)	0.50 (12.70)	0.50 (12.70)	0.50 (12.70)	0.50 (12.70)	0.50 (12.70)	0.50 (12.70)	0.50 (12.70)	0.50 (12.70)	0.50 (12.70)	0.50 (12.70)
	300	0.50 (12.70)	0.50 (12.70)	0.50 (12.70)	0.50 (12.70)	0.50 (12.70)	0.50 (12.70)	0.50 (12.70)	0.50 (12.70)	0.50 (12.70)	0.50 (12.70)	0.50 (12.70)	0.50 (12.70)	0.50 (12.70)	0.50 (12.70)	0.50 (12.70)	0.50 (12.70)	0.50 (12.70)	0.50 (12.70)	0.50 (12.70)	0.50 (12.70)
	150	0.50 (12.70)	0.50 (12.70)	0.50 (12.70)	0.50 (12.70)	0.50 (12.70)	0.50 (12.70)	0.50 (12.70)	0.50 (12.70)	0.50 (12.70)	0.50 (12.70)	0.50 (12.70)	0.50 (12.70)	0.50 (12.70)	0.50 (12.70)	0.50 (12.70)	0.50 (12.70)	0.50 (12.70)	0.50 (12.70)	0.50 (12.70)	0.50 (12.70)

Butt Weld Body

VALVE SIZE	PRESSURE CLASS	1/2" DIM.	3/4" DIM.	1" DIM.	1 1/2" DIM.	2" DIM.	2 1/2" DIM.	3" DIM.	4" DIM.	5" DIM.	6" DIM.	8" DIM.	10" DIM.	12" DIM.	14" DIM.	16" DIM.	18" DIM.	20" DIM.	WEIGHT LBS	KG
1/2"	500	0.50 (12.70)	0.50 (12.70)	0.50 (12.70)	0.50 (12.70)	0.50 (12.70)	0.50 (12.70)	0.50 (12.70)	0.50 (12.70)	0.50 (12.70)	0.50 (12.70)	0.50 (12.70)	0.50 (12.70)	0.50 (12.70)	0.50 (12.70)	0.50 (12.70)	0.50 (12.70)	0.50 (12.70)	0.50 (12.70)	0.50 (12.70)
	300	0.50 (12.70)	0.50 (12.70)	0.50 (12.70)	0.50 (12.70)	0.50 (12.70)	0.50 (12.70)	0.50 (12.70)	0.50 (12.70)	0.50 (12.70)	0.50 (12.70)	0.50 (12.70)	0.50 (12.70)	0.50 (12.70)	0.50 (12.70)	0.50 (12.70)	0.50 (12.70)	0.50 (12.70)	0.50 (12.70)	0.50 (12.70)
	150	0.50 (12.70)	0.50 (12.70)	0.50 (12.70)	0.50 (12.70)	0.50 (12.70)	0.50 (12.70)	0.50 (12.70)	0.50 (12.70)	0.50 (12.70)	0.50 (12.70)	0.50 (12.70)	0.50 (12.70)	0.50 (12.70)	0.50 (12.70)	0.50 (12.70)	0.50 (12.70)	0.50 (12.70)	0.50 (12.70)	0.50 (12.70)

Bill of Materials - Base Valve with Standard Cover

ITEM	QTY	DESCRIPTION	CARBON STEEL	STAINLESS STEEL	ALLOY 20	HASTELLOY
1	1	BODY	CS ASTM A276 GR WFB ▲	SS ASTM A351 GR CF8M ■	SS ASTM A351 GR C7M	HAST ASTM A294 CW6M ◆
2	1	BALL	SS ASTM A276 TYPE 316	SS ASTM A276 TYPE 316	SS ASTM B473 N08020	HAST ASTM B574 L3276
3	2	SEAT ◆	PTFE	PTFE	PTFE	PTFE
4	1	COVER	CS ASTM A276 GR WEB ▲	SS ASTM A351 GR CF8M	SS ASTM A351 GR C7M	HAST ASTM A294 CW6M ◆
5	4	SCREW, HEX HD CAP	CS ASTM A193 GR B7	SS ASTM A193 GR B8	SS ASTM A193 GR B8	SS ASTM A193 GR B8
6	2	NUT, HEX JAM	CS	CS	CS	CS
7	2	SEAL, STEM ◆	PTFE	PTFE	PTFE	PTFE
8	1	GASKET ◆	PTFE	PTFE	PTFE	PTFE
9	1	PIN, GROOVED	SS	SS	SS	SS
10	1	STEM	SS ASTM A276 TYPE 316	SS ASTM A276 TYPE 316	SS ASTM B473 N08020	HAST ASTM B574 L3276
11	1	WASHER, FLAT	CS ASTM A659 GR1018	CS ASTM A659 GR1018	CS ASTM A659 GR1018	CS ASTM A659 GR1018
12	1	RING, GLAND	SS ASTM A276 TYPE 316	SS ASTM A276 TYPE 316	SS ASTM A276 TYPE 316	SS ASTM A276 TYPE 316
13	1	SPRING	SS ASTM A313 TYPE 316	SS ASTM A313 TYPE 316	INCONEL ASTM B637, X750	INCONEL ASTM B637, X750
14	2	WASHER, BELLEVILLE	CS ASTM A664	CS ASTM A664	CS ASTM A664	CS ASTM A664
15	2	RING, SEAT	SS ASTM A240 TYPE 316	SS ASTM A240 TYPE 316	ALLOY 20 ASTM B463 N08020	HAST ASTM B574 L3276
16	1	PLATE, IDENT	SS ASTM A240 TYPE 304	SS ASTM A240 TYPE 304	SS ASTM A240 TYPE 304	SS ASTM A240 TYPE 304
17	2	SCREW, DRIVE	CS	CS	CS	CS
18	1	HANDLE	CS ASTM A216 GR WCB	CS ASTM A216 GR WCB	CS ASTM A216 GR WCB	CS ASTM A216 GR WCB
19	1	SCREW, HEX HD CAP	STEEL	STEEL	STEEL	STEEL
20	1	NUT, HEX	STEEL	STEEL	STEEL	STEEL

- - Buttweld, socketweld and threaded bodies are ASTM A351-CF8M.
- ◆ - Buttweld, socketweld and threaded bodies are ASTM A494-CW2M.
- ◆ - Refer to the "Ordering Information" section of this catalog for specific seat/seal combinations.
- ✖ - Extended covers have three stem seals.
- * - Recommended spare parts. Available as seat/seal kit.
- ▲ - Zinc phosphate coated.

Note: See pages 44-45 for optional materials.

Dimensions, Weights, & Parts Lists

3", 4" and 6" Valves

Flanged Body

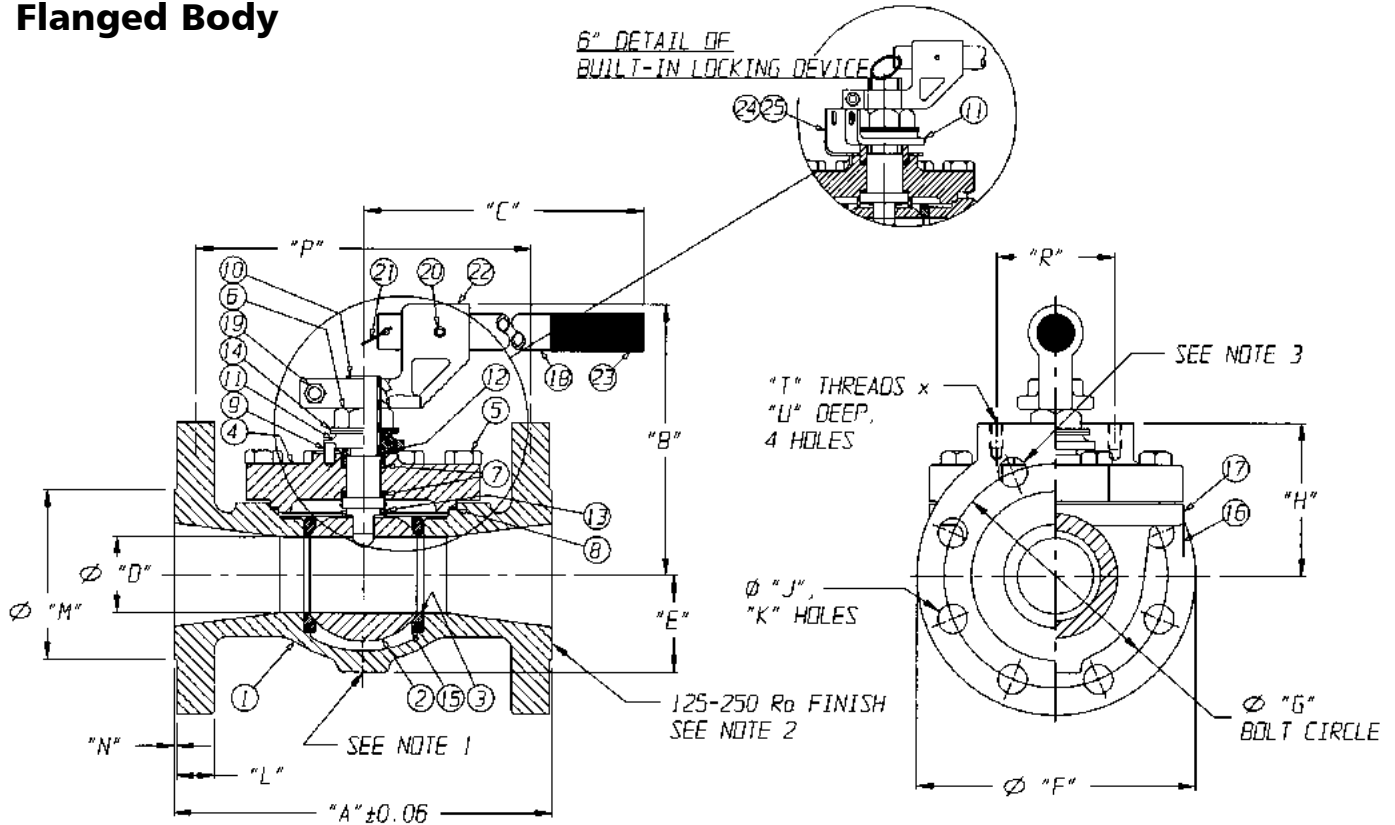

Socket Weld & Threaded Body

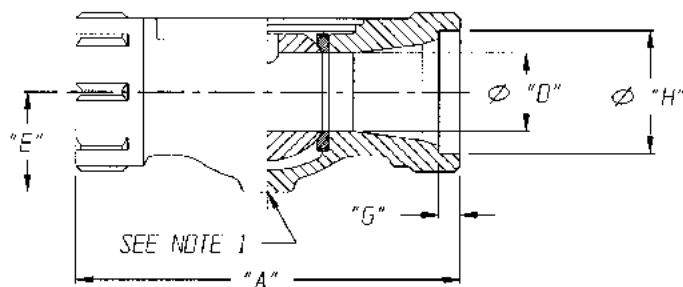

NOTE:

- 1. Body boss can be drilled, tapped, and plugged.**
- 2. End machining meets ANSI B16.5 for flanged ends.**
- 3. Top two flanged bolt holes on 3" & 4" 150 lb. class valves are drilled and tapped 5/8"-11 UNC class 2B. Top two flanged bolt holes on 4" 300# Class valves are drilled and tapped 3/4"-10 UNC class 2B.**
- 4. The design meets ANSI B16.34, MSS-SP 72 and ANSI B16.10.**
- 5. Valve is shown in the open position. Clockwise rotation of stem closes the valve.**

Butt Weld Body

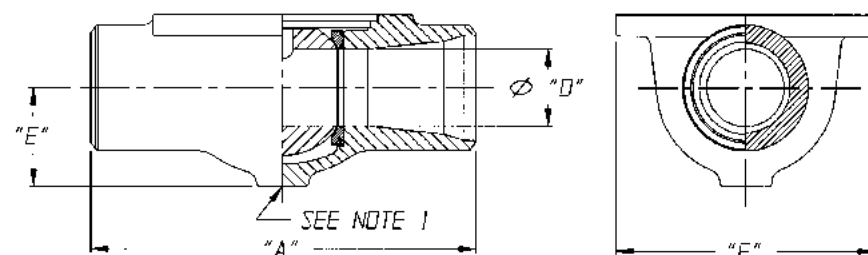

Dimensions, Weights, & Parts Lists

3", 4" and 6" Valves

Flanged Body

VALVE SIZE	PRESSURE CLASS	"A" DIM.	"B" DIM.	"C" DIM.	"D" DIA.	"E" DIM.	"F" DIA.	"G" DIA.	"H" DIM.	"J" DIM.	"K"	"L" DIM.	"M" DIA.	"N" DIM.	"P" DIM.	"R" DIM.	"T" DIM.	"U" DIM.	WEIGHT	
																			LBS	KG
3"	150#	8.00 (203.2)	8.00 (203.2)	15.12 (384.0)	2.25 (57.2)	2.98 (73.2)	7.50 (190.5)	6.00 (152.4)	4.00 (101.6)	0.75 (19.0)	4	0.75 (19.0)	5.00 (127.0)	0.06 (1.5)	7.12 (180.8)	1.50 (38.1)	3/8 16 UNF	0.75 (19.0)	41.0	18.4
	300#	11.12 (282.4)					0.25 (6.4)	6.62 (168.1)	4.50 (114.3)	6.00 (152.4)		1.12 (28.4)		0.25 (6.4)	9.00 (229.0)				77.0	34.5
	600#	14.00 (355.6)					0.25 (6.4)	6.62 (168.1)	4.50 (114.3)	6.00 (152.4)		1.32 (33.5)		0.25 (6.4)	12.12 (307.8)					
4"	150#	9.00 (228.6)	9.00 (228.6)	15.12 (384.0)	3.00 (76.2)	3.38 (85.8)	9.00 (228.6)	7.50 (190.5)	4.88 (124.0)	0.75 (19.0)	6	0.91 (23.1)	6.10 (157.2)	0.06 (1.5)	8.00 (203.2)	4.00 (101.6)	7/16-14 UNF	0.88 (22.4)	54.0	24.3
	300#	12.00 (304.8)					0.25 (6.4)	7.88 (200.2)	5.02 (127.4)	0.88 (22.4)		1.25 (31.8)		0.25 (6.4)	10.88 (276.5)	102.0			45.9	
	600#	17.00 (431.8)					0.25 (6.4)	7.88 (200.2)	5.02 (127.4)	1.00 (25.4)		1.55 (39.5)		0.25 (6.4)	14.00 (355.6)	146.0			65.7	
6"	150#	15.50 (393.7)	12.50 (317.8)	21.37 (542.0)	4.00 (101.6)	4.56 (115.8)	11.00 (279.4)	9.50 (241.3)	6.50 (165.1)	0.88 (22.4)	17	1.00 (25.4)	8.50 (215.9)	0.06 (1.5)	14.88 (377.2)	4.00 (101.6)		0.75 (19.0)	198.4	89.3
	300#	15.88 (403.4)					12.50 (317.8)	21.37 (542.0)	4.00 (101.6)	4.56 (115.8)		12.50 (317.8)		10.62 (269.7)	7.12 (180.8)	1.44 (36.6)		1.44 (36.6)	8.50 (215.9)	0.06 (1.5)

Dimensions in parenthesis () are millimeters.

Socket Weld & Threaded Body

VALVE SIZE	PRESSURE CLASS	"A" DIM.	"B" DIM.	"C" DIM.	"D" DIA.	"E" DIM.	"F" DIM.	"G" DIM.	"H" DIM.	WEIGHT	
										LBS	KG
3"	150-300#	11.12 (282.4)	6.00 (152.4)	15.12 (384.0)	2.25 (57.2)	2.88 (73.2)	7.50 (190.5)	0.63 (16.0)	3.54 (89.9)	42.0	18.9

Butt Weld Body

VALVE SIZE	PRESSURE CLASS	"A" DIM.	"B" DIM.	"C" DIM.	"D" DIA.	"E" DIM.	"F" DIM.	"G" DIM.	"H" DIM.	WEIGHT	
										LBS	KG
3"	150-300#	11.12 (282.4)	6.00 (152.4)	15.12 (384.0)	2.25 (57.2)	2.88 (73.2)	7.50 (190.5)	0.63 (16.0)	3.54 (89.9)	30.0	17.5
	600#	14.00 (355.6)								47.0	21.2
4"	150-300#	12.00 (304.8)	9.00 (229.0)	15.12 (384.0)	3.00 (76.2)	3.38 (85.8)	6.38 (162.8)	0.88 (22.4)	4.00 (101.6)	61.0	27.4
	600#	17.00 (431.8)								80.0	36.0
6"	150-300#	15.88 (403.4)	12.50 (317.8)	21.37 (542.0)	4.00 (101.6)	4.56 (115.8)	12.10 (307.3)	0.88 (22.4)	104.8	74.1	

Bill of Materials - Base Valve with Standard Cover

ITEM	QTY.	DESCRIPTION	CARBON STEEL	STAINLESS STEEL	ALLOY 20	HASTELLOY
1	1	BODY	CS ASTM A216 GR WCB ▲	SS ASTM A351 GR CF8M	ALLOY 20 ASTM A351 GR C276	HAST ASTM A276 TP316
2	1	BALL	SS ASTM A351 CF8M	SS ASTM A351 CF8M	ALLOY 20 ASTM A351 GR C276	HAST ASTM A276 TP316
3	2	SEAL	PTFE	PTFE	PTFE	PTFE
4	1	COVER	CS ASTM A216 GR WCB ▲	SS ASTM A351 GR CF8M	ALLOY 20 ASTM A351 GR C276	HAST ASTM A276 TP316
5	1	SOCKET WELD CONNECTION	CS ASTM A105 GR 60	SS ASTM A105 GR 50	SS ASTM A105 GR 50	SS ASTM A105 GR 50
6	1	SOCKET WELD CONNECTION	CS	SS	SS	SS
7	1	SOCKET WELD CONNECTION	CS	SS	SS	SS
8	1	SOCKET WELD CONNECTION	CS	SS	SS	SS
9	1	SOCKET WELD CONNECTION	CS	SS	SS	SS
10	1	STEM	SS ASTM A276 TYPE 316	SS ASTM A276 TYPE 316	ALLOY 20 ASTM A276 TP316	HAST ASTM A276 TP316
11	1	ROTATIONAL STOP	CS ASTM A216 GR WCB	CS ASTM A216 GR WCB	CS ASTM A216 GR WCB	CS ASTM A216 GR WCB
12	1	WIND WARD	SS ASTM A276 TYPE 316	SS ASTM A276 TYPE 316	SS ASTM A276 TYPE 316	SS ASTM A276 TYPE 316
13	1	SPRING	SS ASTM A313 TYPE 316	SS ASTM A313 TYPE 316	INCONEL ASTM B637, X750	INCONEL ASTM B637, X750
14	2	WASHER BUSHING	CS ASTM A105	SS ASTM A105	ALLOY 20 ASTM A105	SS ASTM A105
15	2	RING GASKET	SS ASTM A276 TYPE 316	SS ASTM A276 TYPE 316	ALLOY 20 ASTM A276 TP316	HAST ASTM A276 TP316
16	1	PLATE, COVER	SS ASTM A276 TYPE 316	SS ASTM A276 TYPE 316	ALLOY 20 ASTM A276 TP316	SS ASTM A276 TYPE 316
17	2	SCREW, DRIVE	CS	SS	SS	SS
18	1	HANDLE	CS ASTM A-57	CS ASTM A-57	CS ASTM A-57	CS ASTM A-57
19	1	SCREW, IN X 1/4 L	STEEL	SS	SS	SS
20	1	SCREW, IN X 1/4 SET	STEEL	SS	SS	SS
21	1	CIRCLE COFFER	STEEL	STEEL	STEEL	STEEL
22	1	JOINT WIPER	CS ASTM A216 GR WCB ▲	CS ASTM A216 GR WCB ▲	CS ASTM A216 GR WCB ▲	CS ASTM A216 GR WCB ▲
23	1	GASKET, HANDLE	PLASTIC	PLASTIC	PLASTIC	PLASTIC
24	2	SCREW, FLAT HD MACH.	STEEL	STEEL	STEEL	STEEL
25	1	PLATE, LOCKING	CS ASTM A216 GR WCB ▲	CS ASTM A216 GR WCB ▲	CS ASTM A216 GR WCB ▲	CS ASTM A216 GR WCB ▲

- ▲ - Buttweld, socketweld and threaded bodies are ASTM A216-GR WCB
- ◆ - Buttweld, socketweld and threaded bodies are ASTM A216-GR WCB
- ◆ - Refer to the "Ordering Information" section of this catalog for specific seat/seal combinations
- ✕ - Extended covers have three stem seals
- Ⓜ - 3" and 4" Class 150 Flanged valves have four top screws
- ★ - Recommended spare parts. Available as seat/seal kits.
- ▲ - Zinc phosphate coated

Note: See pages 44-45 for optional materials.

Dimensions

Extended Bonnet Valves

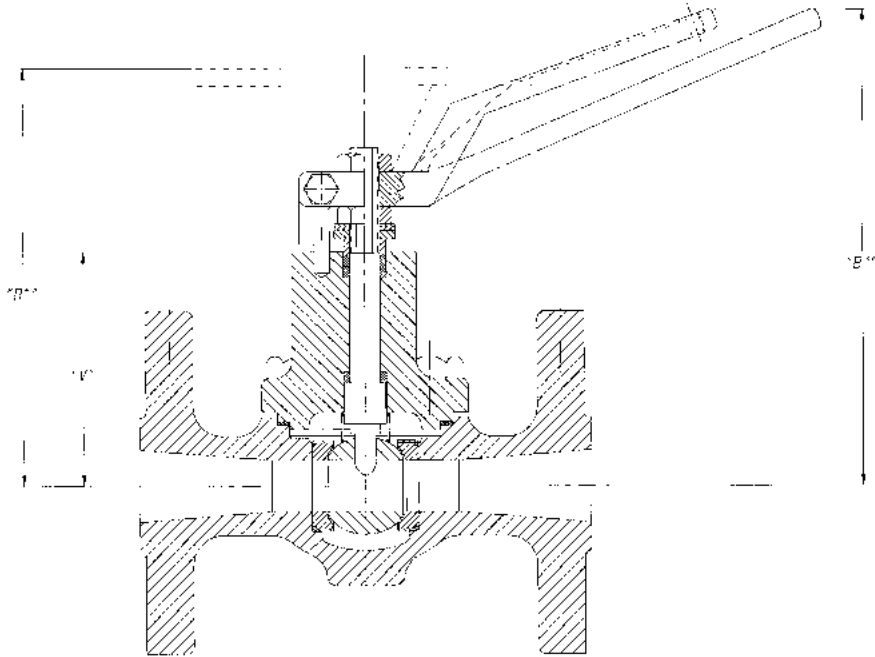

VALV SIZL	"B" DIM	"B1" DIM	"B" DIM
1/2"	6.18 (158.0)	8.12 (206.4)	3.4 (86.0)
3/4"	7.66 (195.0)	9.91 (251.0)	4.14 (105.2)
1"	8.80 (223.5)	11.54 (293.0)	4.84 (123.0)

NUMBERS IN PARENTHESES () ARE IN MILLIMETERS

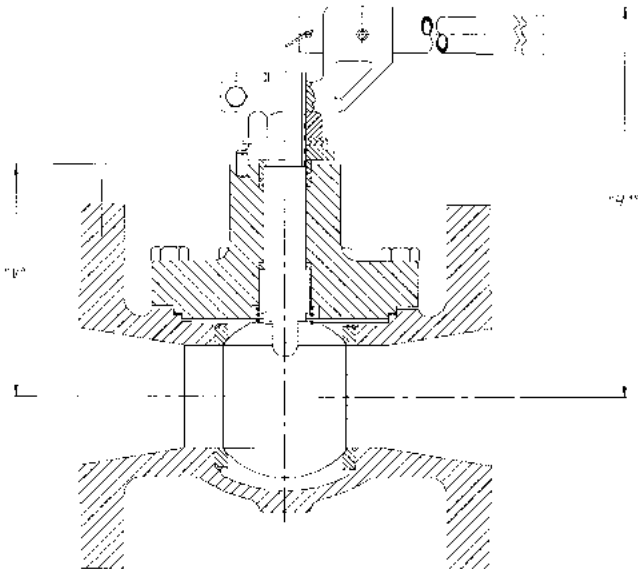

VALV SIZL	"B" DIM	"B" DIM
3"	10.30 (261.6)	6.84 (174.0)
4"	11.45 (291.0)	8.79 (223.0)
6"	13.50 (342.7)	10.62 (270.0)

NUMBERS IN PARENTHESES () ARE IN MILLIMETERS

The basic dimensions shown above are for Cam-Tite Ball Valves with extended bonnets as described on page 9. All components with the exception of the bonnet and stem are interchangeable on valves with standard bonnets. Parts identification and materials are also consistent with the standard bonnet and are described for the various configurations on pages 20–23. For complete dimensions and materials of construction for the extended bonnet, consult the factory.

Dimensions

Severe Service Bonnet Valves

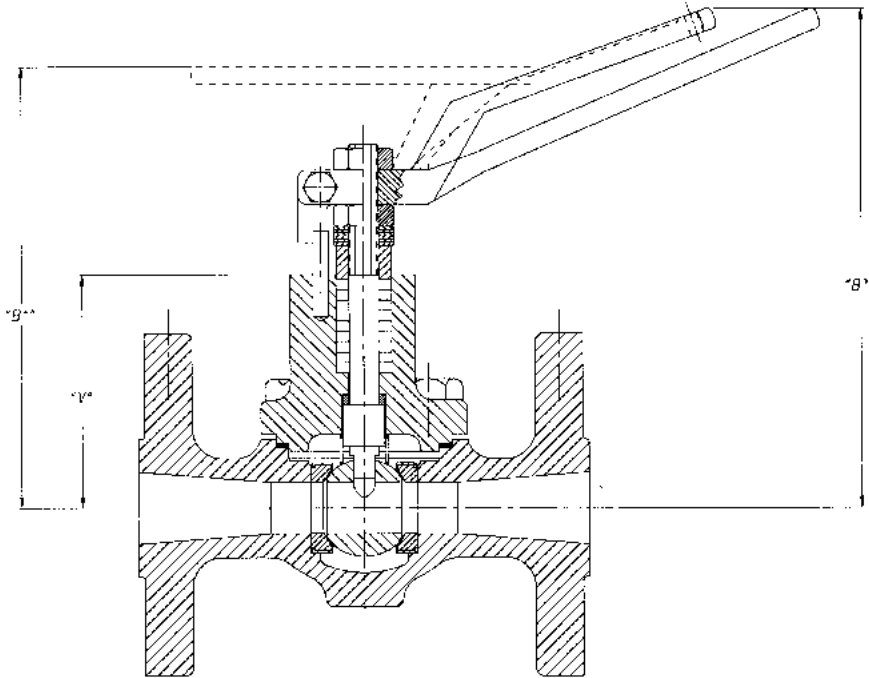

VALVE SIZE	"B" DIM.	"B'" DIM.	"V" DIM.
1/2"	6.91 (175.5)	6.35 (161.5)	3.41 (86.6)
3/4"			
1"			
1-1/2"	8.03 (204.0)	7.19 (182.6)	4.14 (105.2)
2"	9.05 (229.3)	7.90 (199.1)	4.63 (117.6)

NUMERALS IN PARENTHESES () ARE IN MILLIMETERS.

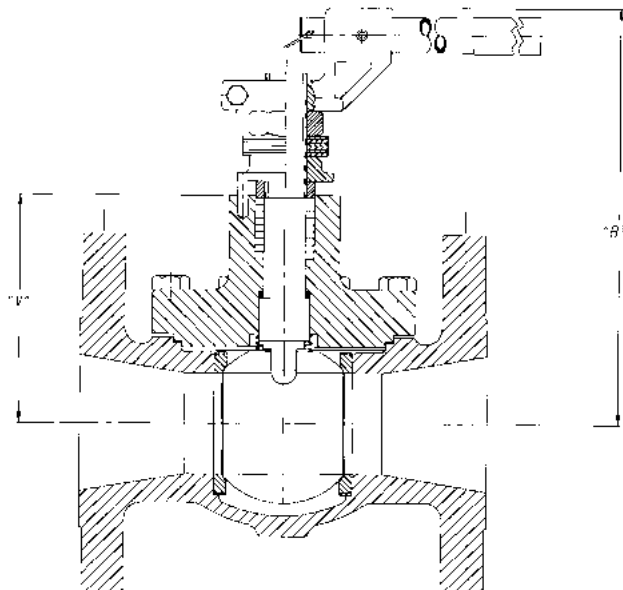

VALVE SIZE	"B" DIM.	"V" DIM.
3"	11.13 (282.7)	5.14 (130.3)
4"	12.32 (313.2)	6.29 (160.5)
6"	15.71 (400.5)	8.62 (218.9)

NUMERALS IN PARENTHESES () ARE IN MILLIMETERS.

The basic dimensions shown above are for Cam-Tite Ball Valves with severe service bonnets as described on page 9. All components with the exception of the bonnet, stem, and stem seals are interchangeable on valves with standard bonnets. Otherwise, parts identification and materials are consistent with the standard bonnet and are described for the various configurations on pages 20–23. For complete dimensions and materials of construction for the severe service bonnet, consult

Actuator Mounting Dimensions — Flange Pads

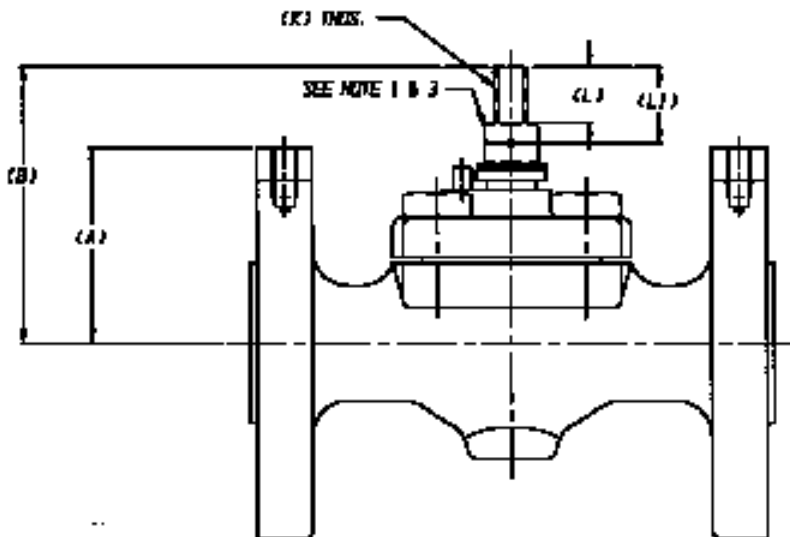
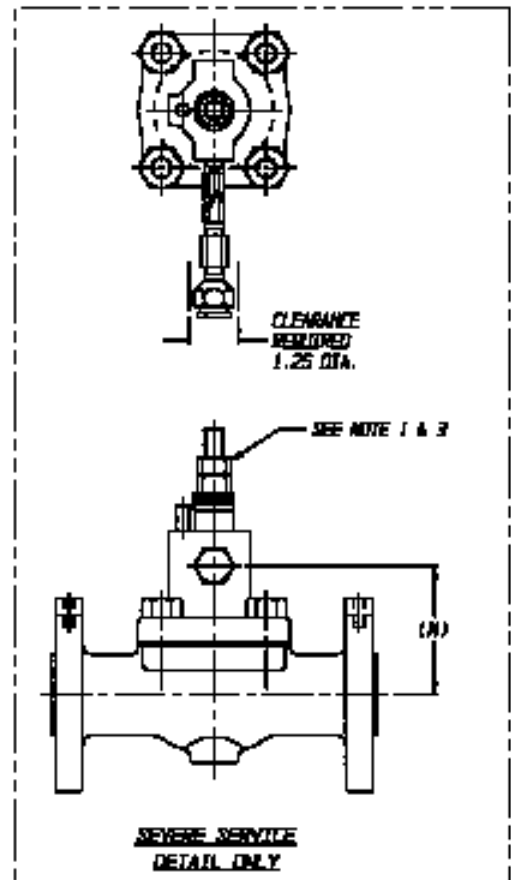
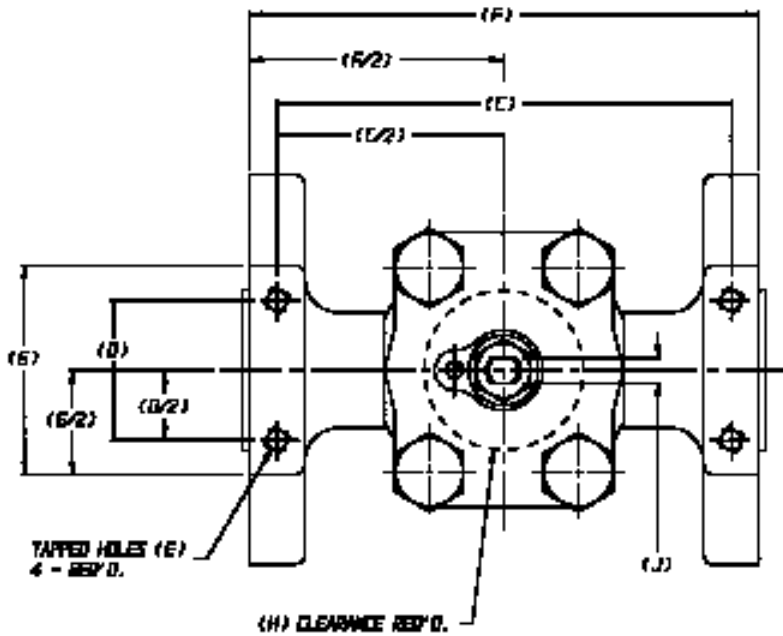

- NOTE:
1. DOUBLE NUTS ON ACTUATED VALVES
0.50" - 2.00" SIZES ONLY.
 2. SINGLE NUT IS USED WITH STEM EXTENSION
KITS FOR ALL SIZES.

VALVE SIZE	PRESS. CLASS	COVER TYPE	(A)	(B)	(C)	(D)	(E)	(F)	(G)	(H)	(J)	(K)	(L)	(LI)	(M)							
1/2"	150#	STANDARD	1.94	3.47	3.62	2.00	0.25-20UNC x 0.38 DP.	4.12	2.00	2.00	0.309 0.305	0.438-14UNC	0.58	0.83	-							
		EXTENDED		4.97									2.31	0.65	0.90	2.78						
		SEVERE SERV.		5.34									2.00	0.58	0.83	-						
	300#	STANDARD	2.06	3.47	4.88			5.38		2.00			2.31	2.00	2.00	0.58	0.83	-				
		EXTENDED		4.97															2.31	0.65	0.90	2.78
		SEVERE SERV.		5.34															2.00	0.58	0.83	-
	600#	STANDARD	2.06	3.47	5.38			6.00		2.00			2.31	2.00	2.00	0.58	0.83	-				
		EXTENDED		4.97															2.31	0.65	0.90	2.78
		SEVERE SERV.		5.34															2.00	0.58	0.83	-
3/4"	150#	STANDARD	2.12	3.47	4.00	2.50	0.312-16UNC x .47/.56 DEEP	4.50	2.62	2.00	0.309 0.305	0.438-14UNC	0.58	0.83	-							
		EXTENDED		4.97									2.31	0.65	0.90	2.78						
		SEVERE SERV.		5.34									2.00	0.58	0.83	-						
	300#	STANDARD	2.50	3.47	5.31			5.88		2.00			2.31	2.00	2.00	0.58	0.83	-				
		EXTENDED		4.97															2.31	0.65	0.90	2.78
		SEVERE SERV.		5.34															2.00	0.58	0.83	-
	600#	STANDARD	2.50	3.47	6.31			7.00		2.00			2.31	2.00	2.00	0.58	0.83	-				
		EXTENDED		4.97															2.31	0.65	0.90	2.78
		SEVERE SERV.		5.34															2.00	0.58	0.83	-
1"	150#	STANDARD	2.56	3.47	4.19	1.75	0.312-16UNC x .47/.56 DEEP	4.88	3.12	2.00	0.309 0.305	0.50-13UNC	0.58	0.83	-							
		EXTENDED		4.97									2.31	0.65	0.90	2.78						
		SEVERE SERV.		5.34									2.00	0.58	0.83	-						
	300#	STANDARD	2.56	3.47	5.69			6.38		2.00			2.31	2.00	2.00	0.58	0.83	-				
		EXTENDED		4.97															2.31	0.65	0.90	2.78
		SEVERE SERV.		5.34															2.00	0.58	0.83	-
	600#	STANDARD	2.56	3.47	7.25			8.00		2.00			2.31	2.00	2.00	0.58	0.83	-				
		EXTENDED		4.97															2.31	0.65	0.90	2.78
		SEVERE SERV.		5.34															2.00	0.58	0.83	-
1 1/2"	150#	STANDARD	3.00	4.10	5.62	1.75	0.312-16UNC x .47/.56 DEEP	6.38	3.12	2.00	0.309 0.305	0.50-13UNC	0.60	0.91	-							
		EXTENDED		5.85									3.19	0.78	1.09	3.32						
		SEVERE SERV.		6.35									2.00	0.60	0.91	-						
	300#	STANDARD	3.31	4.10	6.56			7.38		2.00			2.31	2.00	2.00	0.60	0.91	-				
		EXTENDED		5.85															3.19	0.78	1.09	3.32
		SEVERE SERV.		6.35															2.00	0.60	0.91	-
	600#	STANDARD	3.31	4.10	8.00			9.00		2.00			2.31	2.00	2.00	0.60	0.91	-				
		EXTENDED		5.85															3.19	0.78	1.09	3.32
		SEVERE SERV.		6.35															2.00	0.60	0.91	-
2"	150#	STANDARD	3.12	4.87	6.19	2.25	0.375-16UNC x 0.75 DP.	6.88	3.12	2.50	0.372 0.368	0.625-11UNC	0.97	1.34	-							
		EXTENDED		6.87									3.38	0.93	1.30	3.81						
		SEVERE SERV.		7.19									2.50	0.97	1.34	-						
	300#	STANDARD	3.75	4.87	7.50			8.38		2.50			3.38	2.50	0.97	1.34	-					
		EXTENDED		6.87														3.38	0.93	1.30	3.81	
		SEVERE SERV.		7.19														2.50	0.97	1.34	-	
	600#	STANDARD	3.75	4.87	9.88			11.00		2.50			3.38	2.50	0.97	1.34	-					
		EXTENDED		6.87														3.38	0.93	1.30	3.81	
		SEVERE SERV.		7.19														2.50	0.97	1.34	-	
3"	150#	STANDARD	4.00	5.89	7.12	3.50	0.438-14UNC x 0.88 DP.	7.88	4.62	3.00	0.622 0.618	1.00-8UNC	0.90	-	-							
		EXTENDED		8.14									4.50	1.09	5.03	-						
		SEVERE SERV.		9.22									3.00	0.90	-	-						
	300#	STANDARD	4.50	5.89	9.88			11.00		3.00			4.50	3.00	0.90	-	-					
		EXTENDED		8.14														4.50	1.09	5.03	-	
		SEVERE SERV.		9.22														3.00	0.90	-	-	
	600#	STANDARD	4.50	5.89	12.12			13.50		3.00			4.50	3.00	0.90	-	-					
		EXTENDED		8.14														4.50	1.09	5.03	-	
		SEVERE SERV.		9.22														3.00	0.90	-	-	
4"	150#	STANDARD	4.88	7.11	8.00	4.00	0.438-14UNC x 0.88 DP.	8.88	6.00	3.50	0.747 0.743	1.25-7UNC	1.10	-	-							
		EXTENDED		9.48									5.31	1.08	5.97	-						
		SEVERE SERV.		10.41									3.50	1.10	-	-						
	300#	STANDARD	5.62	7.05	10.69			11.88		3.50			5.31	3.50	1.10	-	-					
		EXTENDED		9.43														5.31	1.08	5.91	-	
		SEVERE SERV.		10.41														3.50	1.10	-	-	
	600#	STANDARD	5.62	7.05	14.88			16.50		3.50			5.31	3.50	1.10	-	-					
		EXTENDED		9.43														5.31	1.08	5.91	-	
		SEVERE SERV.		10.41														3.50	1.10	-	-	
6"	150#	STANDARD	6.50	10.20	14.38	4.00	0.438-14UNC x 0.75 DP.	15.32	5.25	6.00	1.247 1.243	2.00-12UN	1.69	-	-							
		EXTENDED		13.45									6.00	1.30	6.68	-						
		SEVERE SERV.		10.20									6.00	1.69	-	-						
	300#	STANDARD	7.12	10.20	14.38			15.70		6.00			5.31	6.00	1.69	-	-					
		EXTENDED		13.45														6.00	1.30	6.68	-	
		SEVERE SERV.		10.20														6.00	1.69	-	-	
	-	-	-	-	-			-		-			-	-	-	-	-	-	-	-		

Actuator Mounting Dimensions — Bonnet Studs and Double Nuts

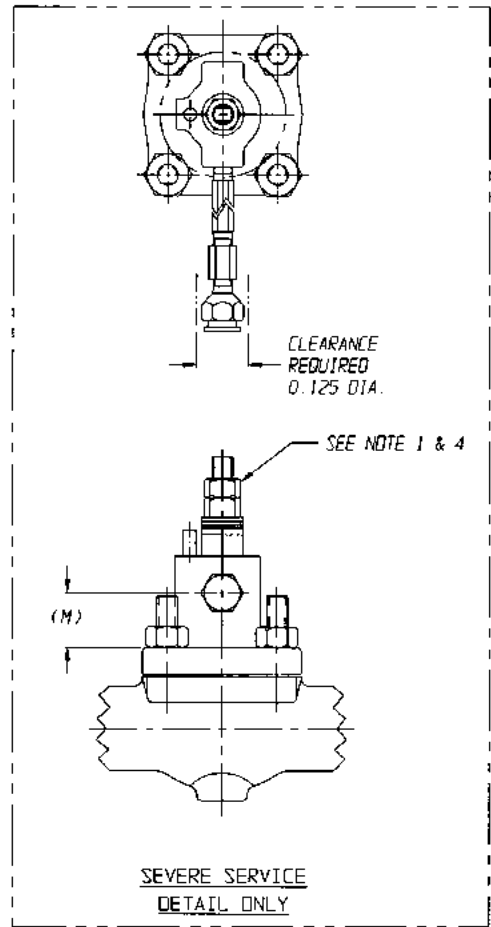
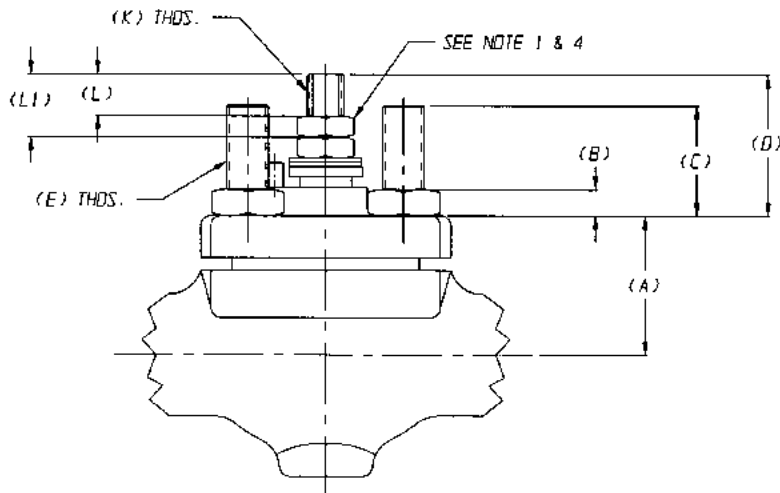
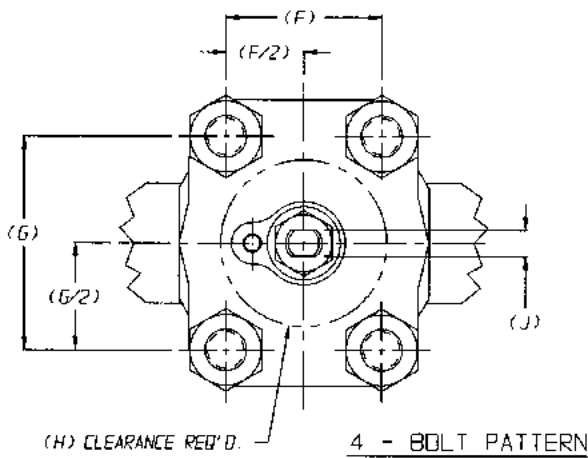
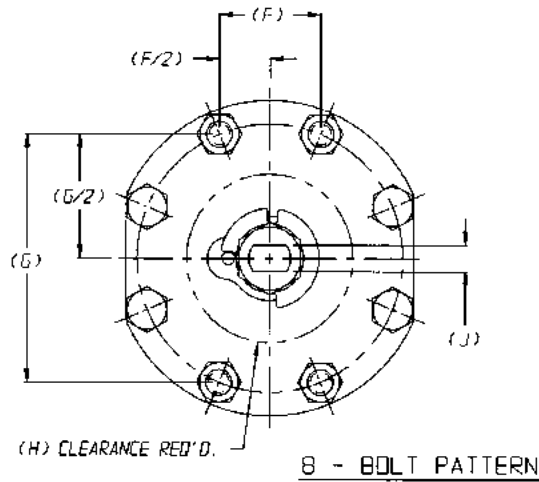

- NOTE:
1. DOUBLE NUTS ON ACTUATED VALVES 0.50" - 2.00" SIZES ONLY.
* 2. INDICATES DIMENSIONS FOR FINISHED HEX. NUTS.
3. SINGLE NUT IS USED WITH STEM EXTENSION KITS FOR ALL SIZES.

VALVE SIZE	PRESS CLASS	COVER TYPE	(A)	(B)**	(C)	(D)	(E)	(F)	(G)	(H)	(J)	(K)	(L)	(L1)	(M)
1/2"	150# (4 BOLT)	STANDARD	1.56	0.448 0.427	1.31	1.91	0.50-13UNC	1.875	2.562	2.00	0.309 0.305	0.438-14UNC	0.58	0.83	-
		EXTENDED				3.41				2.31			0.65	0.90	1.22
		SEVERE SERV.				3.78				2.00			0.58	0.83	-
	300# (4 BOLT)	STANDARD				1.91				2.00			0.65	0.90	1.22
		EXTENDED				3.41				2.31			0.58	0.83	-
		SEVERE SERV.				3.78				2.00			0.65	0.90	1.22
	600# (4 BOLT)	STANDARD				1.91				2.00			0.58	0.83	-
		EXTENDED				3.41				2.31			0.65	0.90	1.22
		SEVERE SERV.				3.78				2.00			0.58	0.83	-
3/4"	150# (4 BOLT)	STANDARD	1.56	0.448 0.427	1.31	1.91	0.50-13UNC	1.875	2.562	2.00	0.309 0.305	0.438-14UNC	0.58	0.83	-
		EXTENDED				3.41				2.31			0.65	0.90	1.22
		SEVERE SERV.				3.78				2.00			0.58	0.83	-
	300# (4 BOLT)	STANDARD				1.91				2.00			0.65	0.90	1.22
		EXTENDED				3.41				2.31			0.58	0.83	-
		SEVERE SERV.				3.78				2.00			0.65	0.90	1.22
	600# (4 BOLT)	STANDARD				1.91				2.00			0.58	0.83	-
		EXTENDED				3.41				2.31			0.65	0.90	1.22
		SEVERE SERV.				3.78				2.00			0.58	0.83	-
1"	150# (4 BOLT)	STANDARD	1.94	0.559 0.535	2.16	2.16	0.625-11UNC	2.625	2.875	2.00	0.372 0.368	0.50-13UNC	0.60	0.91	-
		EXTENDED				3.91				3.19			0.78	1.09	1.38
		SEVERE SERV.				4.41				2.00			0.60	0.91	-
	300# (4 BOLT)	STANDARD				2.16				2.00			0.60	0.91	-
		EXTENDED				3.91				3.19			0.78	1.09	1.38
		SEVERE SERV.				4.41				2.00			0.60	0.91	-
	600# (4 BOLT)	STANDARD				2.16				2.00			0.60	0.91	-
		EXTENDED				3.91				3.19			0.78	1.09	1.38
		SEVERE SERV.				4.41				2.00			0.60	0.91	-
2"	150# (4 BOLT)	STANDARD	2.31	0.559 0.535	1.62	2.56	0.625-11UNC	2.875	3.625	2.50	0.622 0.618	0.625-11UNC	0.97	1.34	-
		EXTENDED				4.56				3.38			0.93	1.30	1.50
		SEVERE SERV.				4.88				2.50			0.97	1.34	-
	300# (4 BOLT)	STANDARD				2.56				2.50			0.97	1.34	-
		EXTENDED				4.56				3.38			0.93	1.30	1.50
		SEVERE SERV.				4.88				2.50			0.97	1.34	-
	600# (4 BOLT)	STANDARD				2.56				2.50			0.97	1.34	-
		EXTENDED				4.56				3.38			0.93	1.30	1.50
		SEVERE SERV.				4.88				2.50			0.97	1.34	-
3"	150# FLGD (4 BOLT)	STANDARD	2.84	0.665 0.617	2.16	3.05	0.625-11UNC	4.125	4.75	3.00	0.747 0.743	1.00-8UNC	0.90	-	-
		EXTENDED				5.30				4.50			1.09	2.19	-
		SEVERE SERV.				6.39				3.00			0.90	-	-
	150/300# (8 BOLT)	STANDARD				2.61				3.00			1.09	1.75	-
		EXTENDED				4.86				4.50			0.90	-	-
		SEVERE SERV.				5.94				3.00			1.09	1.75	-
	600# (8 BOLT)	STANDARD				2.61				3.00			1.09	1.75	-
		EXTENDED				4.86				4.50			0.90	-	-
		SEVERE SERV.				5.94				3.00			1.09	1.75	-
4"	150# FLGD (4 BOLT)	STANDARD	3.35	0.665 0.617	2.34	3.77	0.75-10UNC	2.822	6.814	3.50	0.747 0.743	1.25-7UNC	1.10	-	-
		EXTENDED				6.15				5.31			1.08	2.00	-
		SEVERE SERV.				7.08				3.50			1.10	-	-
	150/300# (8 BOLT)	STANDARD				3.14				3.50			1.08	2.00	-
		EXTENDED				5.52				5.31			1.10	-	-
		SEVERE SERV.				6.44				3.50			1.08	2.00	-
	600# (8 BOLT)	STANDARD				3.14				3.50			1.10	-	-
		EXTENDED				5.52				5.31			1.08	2.00	-
		SEVERE SERV.				6.44				3.50			1.10	-	-
6"	150# (8 BOLT)	STANDARD	4.75	1.012 0.956	3.00	5.45	1.00-8UNC	3.895	9.404	6.00	1.247 1.243	2.00-12UNC	1.69	-	-
		EXTENDED				8.66				1.30			2.39	-	
		SEVERE SERV.				5.45				6.00			1.69	-	-
	300# (8 BOLT)	STANDARD				5.45				6.00			1.69	-	-
		EXTENDED				8.66				6.00			1.30	2.39	-
		SEVERE SERV.				-				-			-	-	-
	-	STANDARD				-				-			-	-	-
		EXTENDED				-				-			-	-	-
		SEVERE SERV.				-				-			-	-	-

Service Guide

The following charts have been assembled based on experiences in actual field installations, as well as from commonly published corrosion data. Due to the many variables involved in determining the degree of compatibility between a certain material and a certain fluid, the charts must be used as a guide only, and cannot be interpreted as a guarantee. Factors such as temperature, concentration, pressure, velocity, aeration, abrasion, cavitation, flashing, etc. play an important application role in determining the suitability of any material in a particular application and must also be taken into consideration.

The selection of a suitable valve body material for a particular application is much easier than the selection of other valve components such as seats, ball, stem and packing. A certain

amount of corrosion is sometimes acceptable on the valve body, but the seats, ball and stem materials must be chosen carefully since corrosion of these components will likely affect the sealing characteristics of the valve.

In addition to the compatibility of the material to the fluid, care must be taken to select materials and designs that are capable of withstanding the actual pressures and temperatures. Consult pages 14-15 of this catalog for pressure/temperature ratings of valves with various seats.

Engineered Valves cannot accept responsibility for the accuracy, currency or reliability of the information contained herein. Selection of materials is at the sole risk of the user.

CONSULT FACTORY FOR SERVICES NOT LISTED.

Chemicals	Body/Trim					Seats/Packing					
	Carbon Steel	316 Stainless Steel	Alloy 20	Monel	Hastelloy C	EPDM	PEEK	Graphite	PTFE	Reinforced (PTFE)	UHMWPP
Acetaldehyde	C	A	A	A	A	B	A	A	A	A	D
Acetamide	B	B			A			A	A	A	
Acetate Solvents	A	A		A	A		A	A	A	A	
Acetic Acid, Aerated	D	A		A	A			A	A	A	
Acetic Acid, Air Free	D	A	A	A	A			A	A	A	
Acetic Acid, Crude	C	A	A	B	A			A	A	A	
Acetic Acid, Glacial		D			A	B	A	A	A	A	
Acetic Acid, Pure	D	A	A	C	A		A	A	A	A	C
Acetic Acid, 10%	C	A	A	B	A	B		A	A	A	A
Acetic Acid, 80%	C	A	A	B	A	C		A	A	A	C
Acetic Acid Vapors		D	B	C	A		A	A	A	A	
Acetic Anhydride	D	B	B	B	A	C	A	A	A	A	C
Acetone	A	A	A	A	A	A	A	A	A	A	A
Acetyl Chloride		C		B	A	D	A	A	A	A	
Acetylene	A	A	A	A	A	A	A	A	A	A	
Acrylonitrile	A	A	B	A	A	D		A	A	A	
Acrylonitrile	A	A	A	A				A	A		
Adipic Acid	A	A	B	B			B		A	A	
Acid Fumes	D	B	B					C	A	A	
Air	A		A	A	A	A	A	B	A	A	A
Albumen		A							A		

A = Excellent

B = Fair

C = Poor

D = Not Recommended

Chemicals	Body/Trim					Seats/Packing					
	Carbon Steel	316 Stainless Steel	Alloy 20	Monel	Hastelloy C	EPDM	PEEK	Graphite	PTFE	Reinforced (PTFE)	UHMWPP
Alcohol, Allyl	A	A	A	A					A	A	
Alcohol, Amyl	B	A	B	B	B	A	A	A	A	A	
Alcohol, Benzyl		A			A				A	A	
Alcohol, Butyl	B	A	A	A	A	C	A	A	A	A	
Alcohol, Diacetone	A	A	A	B	A	B		A	A	A	
Alcohol, Ethyl	B	B	A	B	A	A	A	A	A	A	A
Alcohols, Fatty	B	A	A		A			A	A	A	
Alcohol, Furfuryl		A							A	A	
Alcohol, Isopropyl	B	B	A	B	B	A		A	A	A	
Alcohol, Methyl	B	A	A	A	A	A	A	A	A	A	
Alcohol, Propyl	B	A	A	A	A	A	A	A	A	A	
Alumina		A			A	A	A	A	A	A	
Aluminum Acetate		A	B	C	B	A	A	A	A	A	A
Aluminum Chloride Dry	C	C	D	B	B	A	A	A	A	A	
Aluminum Chloride Solution		D	B	B	A		A	A	A	A	A
Aluminum Fluoride	D	C		B	A	A		A	A	D	A
Aluminum Hydroxide	D	A	B	B	B	A		A	A	A	A
Aluminum Nitrate		C	B	C	B	B		B	A	A	
Alum (Aluminum Potassium Sulfate)		B	B	C	A			A	A	A	A
Aluminum Sulfate	D	B	B	C	A	A		A	A	A	A

Service Guide

Chemicals	Body/Trim				Seats/Packing						
	Carbon Steel	316 Stainless Steel	Alloy 20	Monel	Hastelloy C	EPDM	PEEK	Graphite	PTFE	Reinforced (PTFE)	UHMWPP
Amines	B	A	A	B	B	C	A	A	A	A	
Ammonia, Alum		A	A		A			A	A	A	
Ammonia, Anhydrous Liquid	A	A	A	B	A	B	A	A	A	A	
Ammonia, Aqueous	A	A	A	B	B		A	A	A	A	
Ammonia Gas, Hot		A	A	B	B	A	A	A	A	A	A
Ammonia Liquor		A	A		B			A	A	A	
Ammonia Solutions	B	A	A	B	B	B		A	A	A	
Ammonium Acetate		B	A	B	B	A		A	A	A	
Ammonium Bicarbonate	C	B	B	B		A		A	A	A	A
Ammonium Bromide 5°		B	B	B				A	A	A	A
Ammonium Carbonate	B	B	B	B		A		A	A	A	A
Ammonium Chloride	D	C	B	B	B	A	A	A	A	A	A
Ammonium Hydroxide 28%	C	B	A	D	B	B		A	A	A	A
Ammonium Hydroxide, Concentrated	C	B	A	C	B	A		A	A	A	A
Ammonium Monophosphate	D	B	B	B				A	A		
Ammonium Monosulfate		A	B	B	B			A	A	A	
Ammonium Nitrate	D	A	B	D	B	A		B	A	A	A
Ammonium Persulfate		A	A	D		B		A	A	A	
Ammonium Phosphate	D	B	B	C		A		A	A	A	A
Ammonium Phosphate Di-basic	D	B	B	C	B			A	A	A	
Ammonium Phosphate Tri-basic	D	B	B	C	B		A	A	A		
Ammonium Sulfate	C	B	B	B	B	A		A	A	A	A
Ammonium Sulfide	D	B	B	B		A		A	A	A	A
Ammonium Sulfite	C	A	B	D		B		A	A	A	
Amyl Acetate	C	B	A	B	A	B		A	A	A	A
Amyl Chloride		A	A	B	B	D		A	A	A	D
Aniline	C	B	A	B	B	C		A	A	A	A
Aniline Dyes	C	A	A	A		C		A	A	A	
Antimony Trichloride	D	D	C	B				A	A		
Aqua Regia (Strong Acid)	D	B	B			D	D	D	A	A	C
Aromatic Solvents	C	A	A	B		D		A	A	A	
Arsenic Acid	D	B	B	D	B	B		A	A	A	A
Barium Carbonate	B	B	B	B	A	A		A	A	A	A
Barium Chloride	C	B	C	B		A		A	A	A	A
Barium Cyanide		B	B	D		B		A	A	A	
Barium Hydrate		A	A	B				A	A	A	
Barium Hydroxide	C	B	A	B		B		A	A	A	A
Barium Nitrate		A		A				B	A	A	

Chemicals	Body/Trim				Seats/Packing						
	Carbon Steel	316 Stainless Steel	Alloy 20	Monel	Hastelloy C	EPDM	PEEK	Graphite	PTFE	Reinforced (PTFE)	UHMWPP
Barium Sulfate	C	A	A	B		B		A	A	A	A
Barium Sulfide	C	B	B	C		A		A	A	A	A
Benzaldehyde	A	A	A	B	B	A		A	A	A	D
Benzene (Benzol)	B	B	A	A	B	D	D	A	A	A	D
Benzoid Acid	D	B	B	B	A	D		A	A	A	A
Beryllium Sulfate		B	A	B		B		A	A	A	
Benzyl Chloride	B	B						A	A		
Black Sulfate Liquor	C	B	B	B				A	A		
Bleaching Powders	D	B	B	D				A	A		
Bleaching Powder, Wet		C	B	D	A	B		A	A	A	A
Blood (Meat Juices)		A	A	B		B	A	A	A	A	
Borax (Sodium Borate)	C	A		A	A	A	A	A	A	A	A
Bordeaux Mixture		A	A					A	A	A	
Boric Acid	D	B	B	B	A	B	A	A	A	A	A
Brake Fluid		B		B		B		A	A	A	
Brines, saturated	D	B	B	B	A	A		A	A	A	A
Bromine, Dry	D	D	B	A	A	D	D	B	A	A	D
Bromine, Wet	D	D	D	D				A	A		
Bromic Acid								A	A		
Bunker Oils (Fuel)	B	A	A	A				A	A	A	D
Butadiene	B	A	A	C	B	C	A	A	C	C	D
Butane	B	A	A	B	A	D	A	A	A	A	A
Butyl Acetate		B	A	B	B	D		A	A	A	D
Butylene	A	A	A	A		D	A	A	A	A	
Butyric Acid	D	B	B	B	A	C	A	A	A	A	D
Calcium Bisulfite	D	B	B	D	B	D		A	A	A	
Calcium Carbonate	D	B	B	B	B	B	A	A	A	A	A
Calcium Chlorate		B	B	B		B		B	A	A	A
Calcium Chloride	C	B	B	B	A	B	A	A	A	A	A
Calcium Hydroxide	C	B	B	A	A	A	A	A	A	A	A
Calcium Hypochlorite	D	C	B	C				A	A		
Calcium Nitrate		B	B			B		B	A	A	A
Calcium Phosphate		B	B			B		A	A	A	A
Calcium Silicate		B	B			B		A	A	A	
Calcium Sulfate	C	B	B	B	B	B	A	A	A	A	A
Camphor		B	C	C		B		A	A	A	D
Cane Sugar Liquors		A	A	B		B		A	A	A	
Carbolic Acid (Phenol)	D	B	A	B		B	A	A	A	A	
Carbonated Beverages	D	B	B	C		B		A	A	A	
Carbonated Water	B	A	A	B		A		A	A	A	A
Carbon Bisulfide	B	B	B	B		D		A	A	A	D

A = Excellent

B = Fair

C = Poor

D = Not Recommended

Service Guide

Chemicals	Body/Trim					Seats/Packing					
	Carbon Steel	316 Stainless Steel	Alloy 20	Monel	Hastelloy C	EPDM	PEEK	Graphite	PTFE	Reinforced (PTFE)	UHMWPP
Carbon Dioxide, Dry	A	A	A	A		B		A	A	A	A
Carbon Monoxide		A	A	A	A	B	A		A	A	A
Carbon Tetrachloride, Dry	B	A	A	A	A	D	A	A	A	A	D
Carbon Tetrachloride, Wet	D	B	B	B	B	D	A	A	A	A	D
Castor Oil	B	A	A	A	A	B		A	A	A	A
Caustic Potash (KOH)		A	A	B			B	A	A	A	
Caustic Soda (NaOH)	B	A	A	A		B	B	A	A	A	
Cellulose Acetate		B		B	B	B		A	A	A	
Chlorinated Solvents	C	A	A	B		D	D	A	A	A	
Chlorinated Water		C	A	D	D		D	A	A	A	C
Chlorine, Dry	B	D	B	A	A				A	A	
Chlorine, Wet	D	D	C	D	A				A	A	
Chlorine Gas, Dry	B	B	A	A	A	D	D	A	A	A	D
Chlorobenzene, Dry	B	A	A	B	B	D	B	A	A	A	D
Chloroform, Dry	B	A	A	A	B	D		A	A	A	
Chlorophyll, Dry		B	A	B		B		A	A	A	
Chlorosulfonic Acid, Dry	B	B	B	B	A	D	D		A	D	D
Chlorosulfonic Acid, Wet	D	D	D	C					A	A	
Chrome Alum	B	A	A	B		B		A	A	A	A
Chromic Acid <50%	D	C	B	C	B	C	D	A	A	A	A
Chromic Acid >50%	D	C	B	D	B	C	D	A	A	A	
Chromium Sulfate		B	C	B		B		A	A	A	
Citric Acid	D	B	A	B	A	B	A	A	A	A	A
Coke Oven Gas	B	A	A	B		D		A	A	A	
Cooking Oil	B	A	A	A		D		A	A	A	
Copper Acetate	D	A	A	C	B	B		A	A	A	
Copper Carbonate		A	A					A	A	A	
Copper Chloride	D	D	D	C					A	A	
Copper Cyanide		A	A	C		B		A	A	A	A
Copper Nitrate	D	B	B	D		B		B	A	A	A
Copper Sulfate	D	B	B	C	A	A		A	A	A	A
Corn Oil	C	B	B	B		C		A	A	A	A
Cottonseed Oil	C	B	B	B		C	A	A	A	A	A
Cresol		B	B			D		A	A	A	D
Creosote Oil	B	B	A	B	B	D	A	A	A	A	D
Cresylic Acid	C	B	B	B		D		A	A	A	A
Crude Oil, Sour	B	A	A	B		D		A	A	A	
Crude Oil, Sweet	B	A	A	A			A	A	A	A	
Cumeme	B	B	B	B					A	A	
Cupric Nitrate		A	A	D				B	A	A	
Cutting Oils (Water Emulsions)	B	A		A				A	A	A	

Chemicals	Body/Trim					Seats/Packing					
	Carbon Steel	316 Stainless Steel	Alloy 20	Monel	Hastelloy C	EPDM	PEEK	Graphite	PTFE	Reinforced (PTFE)	UHMWPP
Cyanide Plating Solution		B	B	D		B			A	A	
Cyclohexane	A	A	A	B	B	D	A	A	A	A	C
Cyclohexanone		A	A	B	B		B	A	A	A	D
Denatured Alcohol	B	A	A	A					A	A	
Detergents, Synthetic		B	A	B		B		A	A	A	A
Dextrin		B	B	B		B		A	A	A	A
Diacetone Alcohol	A	A	A	A					A	A	
Diamylamine		A	A						A	A	
Dibutyl Phthalate									A	A	
Dichloroethane		C	B	B		D		A	A	A	
Dichloroethyl Ether		B	B			D			A	A	
Diesel Oil Fuels	A	A	A	A		D		A	A		
Diethylamine	A	A	A	B		C		A	A	A	
Diethyl Benzene		B	B			D		A	A	A	
Diethylene Glycol		A	A	B		A	A	A	A	A	A
Diethyl Sulfate		B	B	B		C		A	A	A	
Dimethyl Formamide		A	A	B		D	A	A	A	A	
Dimethyl Phthalate		D						A	A	A	
Dioxane		B	B	B		C	A	A	A	A	
Dipentane (Pinene)		A	A			D		A	A	A	
Disodium Phosphate		B	B	C				A	A	A	A
Dowtherm	B	A	A	A		D	A	A	A	A	
Drilling Mud	B	A	A	B		A		A	A	A	
Dry Cleaning Fluids	B	A	A	B				A	A	A	
Drying Oil	C	B	B	B				A	A	A	
Enamel		A				D		A	A	A	
Epsom Salts (MgSo4)	C	B	B	B				A	A	A	
Ethane	C	B	B	B		D	A	A	A	A	
Ether	A	A	A	B		C	A	A	A	A	D
Ethyl Acetate	B	B	B	B	B	C		A	A	A	C
Ethyl Acrylate	C	A	A	B	A	C		A	A	A	
Ethylamine		A							A	A	A
Ethyl Benzene		B	A		A	D		A	A	A	
Ethyl Bromide		B	C	B		B		A	A	A	
Ethyl Chloride, Dry	B	A	A	B	B	C		A	A	A	D
Ethyl Chloride, Wet	D	B	B	B	B	B		A	A	A	A
Ethylene	A	A	A	A					A	A	
Etylenediamene		A							A	A	
Ethylene Chloride			A	A	B	B		A	A	A	
Ethylene Dichloride, Dry	B	A	A	A					A	A	
Ethylene Dichloride, Wet	D	C	A	B					A	A	

A = Excellent

B = Fair

C = Poor

D = Not Recommended

Service Guide

Chemicals	Body/Trim					Seats/Packing					
	Carbon Steel	316 Stainless Steel	Alloy 20	Monel	Hastelloy C	EPDM	PEEK	Graphite	PTFE	Reinforced (PTFE)	UHMWPP
Ethylene Glycol	B	B	A	B	A	A	A	A	A	A	A
Ethylene Oxide	B	B	B	B	A	D	A	D	A	A	C
Ethyl Ether		A	A	A	B	D	A	A	A	A	
Ethyl Silicate		B	B	B		B		A	A	A	
Ethyl Sulfate		B	B			C		A	A	A	
Fatty Acids	D	A	A	B	A	D	A	A	A	A	A
Ferric Chloride	D	D	D	D				A	A		
Ferric Hydroxide		A	A	A				A	A	A	
Ferric Nitrate	D	C	A	D	B	A		B	A	A	A
Ferric Sulfate	D	B	A	D		A		A	A	A	A
Ferrous Ammonium Citrate		B	B					A	A	A	A
Ferrous Chloride	D	D	D	D	D	A		A	A	A	A
Ferrous Sulfate	D	B	B	B	B	A		A	A	A	A
Ferrous Sulfate, Saturated	C	A	A	B	B	B		A	A	A	
Fertilizer Solutions	B	B	B	B				A	A	A	
Fish Oils	B	A	A	A		D		A	A	A	
Flue Gases		A	A	B		D		A	A	A	
Fluoride Salts		B						A	D		
Fluorine Gas, Dry		B	A	A	A		D		A	D	
Fluoboric Acid		B	A					A	D	A	
Fluorosilicic Acid	D	B	B	A	B	C			A	D	A
Formaldehyde, Cold	A	A	A	A	B	B		A	A	A	A
Formaldehyde, Hot	D	C	B	B	B			A	A	A	A
Formic Acid, Cold	D	B	A	B	A			A	A	A	A
Formic Acid, Hot	D	B	B	B	B			A	A	A	A
Freon Gas, Dry	B	A	A	A	B	C	A	A	A	A	
Freon 11, MF, 112, BF		A	A	B	B	C	A	A	A	A	
Freon 12, 13, 32, 114, 115		A	A	B	B	A	A	A	A	A	
Freon 21, 31		A	A	B	B	D	A	A	A	A	
Freon 22		A	A		B	D	A	A	A	A	
Freon 113, TF		A	A	B	B	C	A	A	A	A	
Freon, Wet		C	B	B	B	B	D	A	A	A	
Fuel Oil	B	A	A	B			D	A	A	A	D
Fumaric Acid			A						A	A	
Gallic Acid 5%	D	B	B	B	B	C			A	A	A
Gas, Manufactured	B	B	B	A		D		A	A	A	
Gas, Natural	B	A	B	A		D		A	A	A	
Gas, Odorizers	B	B	A	B				A	A	A	
Gasoline, Aviation	A	A	A	A	A			A	A	A	D
Gasoline, Leaded	A	A	A	B	A			A	A	A	D
Gasoline, Motor	A	A	A	A	A	D		A	A	A	D

Chemicals	Body/Trim					Seats/Packing					
	Carbon Steel	316 Stainless Steel	Alloy 20	Monel	Hastelloy C	EPDM	PEEK	Graphite	PTFE	Reinforced (PTFE)	UHMWPP
Gasoline, Refined	B	A	A	B	A	D		A	A	A	D
Gasoline, Sour	B	A	A	C	A	D		A	A	A	D
Gasoline, Unleaded	A	A	A	A	A			A	A	A	D
Glue	A	B	A	B	A	B	A	A	A	A	A
Glutamic Acid		B	A						A	A	
Glycerine (Glycerol)	C	A	A	A	A	A	A	A	A	A	A
Glycol Amine		B			D	D		A	A	A	
Glycol	C	B	A	B		A	A	A	A	A	
Helium Gas		A	A	B	A	B	A	A	A	A	A
Heptane	B	A	A	B	A	D	A	A	A	A	C
Hexane	B	A	A	B	A	D	A	A	A	A	D
Hexanol, Tertiary	A	A	A	A	A	D		A	A	A	A
Hydraulic Oil, Petroleum Base	A	A	A	A		D		A	A	A	
Hydrazine		B	B	D		B			A	A	
Hydrobromic Acid	D	D	D	D					A	A	
Hydrochloric Acid	D	D	D	D					A	A	
Hydrocyanic Acid	D	A	A	C	B	B	A		A	A	A
Hydrofluoric Acid, Anhydrous	B	B	B	A					A	D	
Hydrofluosilicic Acid	D	C	B	B		B	D	A	A	D	
Hydrogen Gas, Cold	B	A	A	A		B	A	A	A	A	A
Hydrogen Gas, Hot	B	B	A		A	B	A	A	A	A	A
Hydrogen Bromide Gas									A	A	
Hydrogen Chloride Gas, Dry	D	B	A	B					A	A	
Hydrogen Peroxide, Concentrated	D	B	B	D	D	B	A	D	A	A	C
Hydrogen Peroxide, Dilute	D	B	B	D	D	B	A	C	A	A	A
Hydrogen Sulfide, Dry	B	A	B	B	B	A	A	A	A	A	A
Hydrogen Sulfide, Wet	C	B	B	C	D	B	A	A	A	A	A
Hypo (Sodium Thiosulfate)	D	B	B	B		A		A	A	A	
Illuminating Gas	A	A	A	A		D		A	A	A	
Ink-Newsprint	D	A	A	B		B		A	A	A	A
Iso-Butane		B	B			D		A	A	A	
Iso-Octane	A	A	A	A		D	A	A	A	A	
Isopropyl Acetate		B	A			D	A	A	A	A	
Isopropyl Ether	A	A	A	B	A	D	A	A	A	A	
J P-4 Fuel	A	A	A	A	A			A	A	A	A
J P-5 Fuel	A	A	A	A	A			A	A	A	A
J P-6 Fuel	A	A	A	A	A			A	A	A	A
Kerosene	B	A	A	A	A	D	A	A	A	A	C
Ketones	A	A	A	A		D	A	A	A	A	
Lacquer (and Solvent)	C	A	A	A		D	A	A	A	A	

A = Excellent

B = Fair

C = Poor

D = Not Recommended

Service Guide

Chemicals	Body/Trim					Seats/Packing					
	Carbon Steel	316 Stainless Steel	Alloy 20	Monel	Hastelloy C	EPDM	PEEK	Graphite	PTFE	Reinforced (PTFE)	UHMWPP
Lactic Acid Concentrated, Cold	D	A	A	D	A	B	A	A	A	A	A
Lactic Acid Concentrated, Hot	D	B	A	D	B	B	A	A	A	A	A
Lactic Acid Dilute Cold	D	A	A	C	A	B	A	A	A	A	A
Lactic Acid Dilute Hot	D	A	A	D	B		A	A	A	A	A
Lactose		B	B	B		B		A	A	A	
Lard Oil	C	B	A	B		B	A	A	A	A	A
Lead Acetate	D	B	B	B		B	A	A	A	A	A
Lead Arsenate	B								A	A	
Lead Oxide									A	A	
Lead Sulfate		B	B	B		B		A	A	A	
Lecithin		B	B	B		D			A	A	
Linoleic Acid	B	A	A	B		D		A	A	A	
Linseed Oil	A	A	A	B		D	A	A	A	A	A
Lithium Chloride		B	A	B		B	A	A	A	A	
LPG	B	B	B	B		D	A	A	A	A	
Lubricating Oil (Petroleum Based)	A	A	A	B		D		A	A	A	C
Lye — See Sodium Hydroxide & Potassium Hydroxide											
Magnesium Bisulfate	B	A	A	B		B	A	A	A	A	
Magnesium Bisulfide		B	B	B		B	A	A	A	A	
Magnesium Carbonate		A	A	B		B	A	A	A	A	A
Magnesium Chloride	C	B	B	B	A	A	A	A	A	A	A
Magnesium Hydroxide	B	A	A	B	B	A	A	A	A	A	A
Magnesium Hydroxide, Hot	B	A	A	A	B		A	A	A	A	A
Magnesium Oxide									A	A	
Magnesium Nitrate		A	A	B			A	B	A	A	A
Magnesium Sulfate	B	A	A	B	A	A	A	A	A	A	A
Maleic Acid	B	B	B	B	A	D	A	A	A	A	A
Maleic Anhydride		B	B	B	B	D		A	A	A	
Malic Acid	D	B	B	B			A	A	A	A	
Manganese Carbonate		B	A				A	A	A	A	
Manganese Sulfate		A	A	B		B	A	A	A	A	
Meat Juices		A	A					A	A	A	A
Melamine Resins		C	C					A	A	A	
Methanol		A	A	B		D		A	A	A	
Mercuric Chloride	D	B	B	D	B	A	A	A	A	A	A
Mercuric Cyanide	D	A	A	C	B	A	A	A	A	A	A
Mercurous Nitrate		A	A	D			A	B	A	A	A
Mercury	A	A	A	B	B	A	A	A	A	A	A
Methane	B	A	A	B	A			A	A	A	A
Methyl Acetate	B	A	A	B	A	B	A	A	A	A	

Chemicals	Body/Trim					Seats/Packing					
	Carbon Steel	316 Stainless Steel	Alloy 20	Monel	Hastelloy C	EPDM	PEEK	Graphite	PTFE	Reinforced (PTFE)	UHMWPP
Methyl Acetone	A	A	A	A		A	A	A	A	A	
Methylamine	B	A	A	C	B	B	A	A	A	A	
Methyl Bromide 100%		B	A	B		D	A	A	A	A	D
Methyl Cellosolve	B	A	A	B	B	B		A	A	A	
Methyl Cellulose		A	A		B			A	A	A	
Methyl Chloride	B	A	A	B		D	A	A	A	A	D
Methyl Ethyl Ketone	A	A	A	A	B	B	C	A	A	A	D
Methylene Chloride	B	A	A	B	B	D	A	A	A	A	D
Methyl Formate	C	B	A	B	B	B		A	A	A	
Methyl Isobutyle Ketone		A	A					A	A	A	
Mineral Oils	B	A	A	A		D	A	A	A	A	D
Mine Water (Acid)	D	C	C	C				A	A		
Mineral Spirits	B	B	B	B				A	A	A	D
Molybdic Acid		A	A					A	A	A	
Monochloroacetic Acid	D	D	C	D				A	A		
Monocloro Benzene, Dry		B	B	B			B	A	A	A	
Morpholine		A	A	B		B		A	A	A	
Muriatic Acid	D	D	D	D	D			A	A		
Naptha	B	B	B	B	A	D	A	A	A	A	D
Napthalene	B	B	B	B	B	D	A	A	A	A	D
Natural Gas, Sour	B	A	A	D	A	D	A	A	A	A	A
Nickel Ammonium Sulfate	D	A	A	C			B	A	A	A	
Nickel Chloride	D	B	A	B	A	B	A	A	A	A	A
Nickel Nitrate	D	B	A	B			A	A	B	A	A
Nickel Sulfate	D	B	A	B	B	B	A	A	A	A	A
Nicotinic Acid (Niacin)	B	A	A	A		D		A	A	A	A
Nitric Acid 10%	D	A	A	D			B	B	A	A	A
Nitric Acid 30%	D	A	A	D			B	B	D	A	A
Nitric Acid 80%	D	C	B	D		D	D	D	A	A	D
Nitric Acid 100%	D	A	A	D		D	D	D	A	A	D
Nitric Acid Anhydrous	D	A	A	D		D	D	D	A	A	
Nitrobenzene	B	A	A	B	B	C	C	A	A	A	D
Nitrocellulose	B	B	B	B				A	A		
Nitrogen	A	A	A	A		B	A	A	A	A	A
Nitrous Acid 10%	D	B	B	D				D	A	A	A
Nitrous Gases	B	A	A	D				A	A	A	A
Nitrous Oxide	B	B	B	D	B			A	A	A	A
Oil, Linseed	A	A	A	B				A	A		
Oil, Lubricating	A	A	A	B				A	A		
Oils Petroleum Refined	A	A	A	A	A	D	A	A	A	A	
Oils, Petroleum Sour	B	A	A	A	A	D	A	A	A	A	

A = Excellent

B = Fair

C = Poor

D = Not Recommended

Service Guide

Chemicals	Body/Trim				Seats/Packing						
	Carbon Steel	316 Stainless Steel	Alloy 20	Monel	Hastelloy C	EPDM	PEEK	Graphite	PTFE	Reinforced (PTFE)	UHMWP
Oils Water Mixture	B	A	A		A	A	A	A	A		
Olaic Acid		B	B	A			A	A	A		
Oleic Acid	C	B	A	B	B	D	D	A	A	A	C
Oleum	B	B	B	C	B	D		A	A	D	
Oleum Spirits		B	B	D		D		A	A		
Olive Oil	B	A	A	A		B	A	A	A	A	A
Oxalic Acid	D	B	B	B		B	A	A	A	A	A
Oxygen	B	A	A	A	A	A	D	D	A	A	A
Ozone, Dry	A	A	A	A	A	A	D		A	A	C
Ozone, Wet	C	A	A	A	A	B	D		A	A	C
Paints & Solvents	A	A	A	A		D		A	A	A	A
Palmitic Acid	C	B	B	B		B	A	A	A	A	
Palm Oil	C	B	A	A		D		A	A	A	A
Paraffin	B	A	A	A	A	D	A	A	A	A	C
Paraformaldehyde	B	B	B	B		D		A	A	A	
Paraldehyde		B	B			D		A	A	A	
Pentane	B	A	A	B		D	A	A	A	A	
Perchlorethylene, Dry	B	A	A	B	B	D		A	A	A	
Phenol	D	A	A	A	A	D		A	A	A	D
Phosphate Ester	A	A	A	A		A		A	A	A	
Phosphoric Acid 10% Cold	D	C	B	C				A	A		
Phosphoric Acid 10% Hot	D	C	B	B				A	A		
Phosphoric Acid 50% Cold	D	B	B	C		B	D	A	A	A	A
Phosphoric Acid 50% Hot	D	D	B	C		B	D	A	A	A	A
Phosphoric Acid 85% Cold	B	A	B	A			D	A	A	A	A
Phosphoric Acid 85% Hot	C	B	B				D	A	A	A	A
Phosphoric Anhydride		A	A				D	A	A	A	
Phosphorous Trichloride	B	A	A			B	D	A	A	A	A
Phthalic Acid	C	B	B	A	B		B	A	A	A	
Phthalic Anhydride	C	B	B	A	A			A	A	A	A
Pine Oil	B	A	A	B		D		A	A	A	D
Pitch (Bitumen)		A	A			D		A	A	A	
Polysulfide Liquor		B	A	B		B		A	A	A	
Polyvinyl Acetate		B	B	B		B		A	A	A	
Polyvinyl Chloride		B	B	B	B			A	A	A	
Potassium Bicarbonate		A	A	B				A	A	A	A
Potassium Bichromate		A	A	A				A	A	A	
Potassium Bisulfate		A	A	B				A	A	A	
Potassium Bisulfite	D	B	B	D	B			A	A	A	
Potassium Bromide	D	A	B	B	B			A	A	A	A
Potassium Carbonate	B	B	B	B		B		A	A	A	A
Potassium Chlorate	B	B	B	C		B		C	A	A	A
Potassium Chloride	C	B	A	B	B	A		A	A	A	A
Potassium Chromate		B	B	B		B		A	A	A	A
Potassium Cyanide	B	B	B	B	B	A		A	A	A	A
Potassium Dichromate	C	B	A	B		B		A	A	A	A
Potassium Ferricyanide	C	A	B	B		B		A	A	A	A
Potassium Ferrocyanide	C	B	B	A				A	A	A	A
Potassium Hydroxide, Dilute Cold	A	B	B	A				A	A	A	A
Potassium Hydroxide, To 70%, Cold	B	B	B	A		B		A	A	A	A
Potassium Hydroxide, Dilute Hot	B	B	B	A				A	A	A	A
Potassium Hydroxide, To 70%, Hot	A	B	B	A		A		A	A	A	A
Potassium Iodide	C	B	B	B	B	B		A	A	A	
Potassium Nitrate	B	B	B	B	B	B		B	A	A	A
Potassium Oxalate		A	A					A	A	A	A
Potassium Permanganate	B	B	B	B	B	B	D		A	A	A
Potassium Phosphate		B	B	B	B	A	D		A	A	A
Potassium Phosphate, Di-basic	A	A	A	B	B	B		A	A	A	
Potassium Phosphate, Tri-basic	A	B	B	B		B		A	A	A	
Potassium Sulfate	B	A	A	B		A		A	A	A	A
Potassium Sulfide	B	A	A	C	A	B		A	A	A	A
Potassium Sulfite	B	A	A	C	B	A		A	A	A	A
Propane Gas B	B	A	B	A	D	A	A	A	A	A	
Propionic Acid	D	B	B	B				A	A		
Propyl Alcohol	B	A	A	A				A	A		
Propyl Bromide		B	A	B		B		A	A	A	
Propylene Glycol	B	B	B	B		B	A	A	A	A	A
Pyridine		B	A					A	A	A	
Pyrolgalic Acid	B	B	A	B				A	A		
Pyroligenous Acid		A	B					A	A		
Quinine, Sulfate, Dry		A	A	B				A	A	A	
R P-1 Fuel	A	A	A	A				A	A	A	
Rubber Latex Emulsions	B	A	A					A	A	A	
Salicyclic Acid	D	A	B	B		B	A	A	A	A	A
Salt (NaCl)	C	B	A	A				A	A	A	A
Salt Brine		B	B	B		B	A	A	A	A	A
Sea Water	D	B	B	A		A	A	A	A	A	A
Sewage	C	B	B	B		B	A	A	A	A	A

A = Excellent

B = Fair

C = Poor

D = Not Recommended

Service Guide

Chemicals	Body/Trim				Seats/Packing						
	Carbon Steel	316 Stainless Steel	Alloy 20	Monel	Hastelloy C	EPDM	PEEK	Graphite	PTFE	Reinforced (PTFE)	UHMW
Shellac	A	A	A	A		A	A	A	A		
Silicone Fluids		B	B			A	A	A	A	C	
Silver Bromide		A	A	B			A	A	A		
Silver Cyanide		A	A	B			A	A	A		
Silver Nitrate	D	A	A	D	A		B	A	A	A	
Silver Plating Sol.		A	A					A	A		
Soap Solutions (Stearates)	A	A	A	A	A		A	A	A		
Sodium Acetate	C	B	B	B	B	B	A	A	A	A	A
Sodium Aluminate	C	A	B	B	B	B	A	A	A	A	
Sodium Benzoate		B	B	B			A	A	A	A	A
Sodium Bicarbonate	C	B	A	B		A	A	A	A	A	A
Sodium Bichromate		B	B				A	A	A		
Sodium Bisulfate 10%	D	A	A	B		B	A	A	A	A	A
Sodium Bisulfite 10%	D	A	B	B	B	B	A	A	A	A	A
Sodium Borate	C	B	B	B		B	A	A	A	A	A
Sodium Bromide 10%	C	B	B	B		B		A	A	A	A
Sodium Carbonate (Soda Ash)	B	A	A	B	B	B		A	A	A	A
Sodium Chlorate	C	B	B	C	B	B		B	A	A	A
Sodium Chloride	C	B	A	A	B	B		A	A	A	A
Sodium Chromate	B	A	B	B		B		A	A		
Sodium Citrate		B	B					A	A	A	
Sodium Cyanide	B	A	A	B		B		A	A	A	
Sodium Ferricyanide		A	A	B				A	A	A	A
Sodium Fluoride	D	B	A	B		B	A	A	A	D	A
Sodium Hydroxide, 20% Cold	A	A	B	A		B	A	A	A	D	A
Sodium Hydroxide, 20% Hot	B	A	A	A		B		A	A	D	A
Sodium Hydroxide, 50% Cold	A	A	A	A		B		A	A	D	A
Sodium Hydroxide, 50% Hot	B	A	A	B				A	A	D	A
Sodium Hydroxide, 70% Cold	A	A	B	A		B		A	A	D	A
Sodium Hydroxide, 70% Hot	B	A	B	B		B		A	A	D	A
Sodium Hypochlorite (Bleach)	D	D	C	D	A			A	A	A	A
Sodium Hyposulfite		B	B	B				A	A	A	
Sodium Lactate		A	A	B				A	A	A	
Sodium Metaphosphate	B	B	B		A	B		A	A	A	
Sodium Metasilicate Cold	C	A	A	A				A	A	A	
Sodium Metasilicate Hot	D	A	A	A	A			A	A	A	
Sodium Nitrate	B	A	A	B	B	B	D		A	A	A
Sodium Nitrite		B	B	C	B	A		B	A	A	A
Sodium Perborate	B	B	B	B	B	A		A	A	A	
Sodium Peroxide	C	B	B	B	B	A		A	A	A	

Chemicals	Body/Trim				Seats/Packing						
	Carbon Steel	316 Stainless Steel	Alloy 20	Monel	Hastelloy C	EPDM	PEEK	Graphite	PTFE	Reinforced (PTFE)	UHMW
Sodium Phosphate	C	B	B	B	B	A		A	A	A	A
Sodium Phosphate, Di-basic	C	B	B	B	B	A		A	A	A	
Sodium Phosphate, Tri-basic	C	B	B	B	B	A		A	A	A	
Sodium Polyphosphate		B	B	B	B	A		A	A	A	
Sodium Salicylate		A	A					A	A	A	
Sodium Silicate	B	B	B	B		B	A	A	A	A	A
Sodium Silicate, Hot	C	B	B	B		B	A	A	A	A	A
Sodium Stearate		B						A	A		
Sodium Sulfate	B	A	A	A		A		A	A	A	A
Sodium Sulfide	B	B	B	B		B		A	A	A	A
Sodium Sulfite		A	A	B	B	B		A	A	A	A
Sodium Tetraborate		A	A			B		A	A	A	
Sodium Thiosulfate	B	B	B	B		A		A	A	A	
Soybean Oil	C	A	A	A		B	A	A	A	A	A
Stannous Chloride	D	B	A	C				A	A		
Stannous Fluoride		B	B					A	D		
Starch	C	B	A	A		C	A	A	A	A	A
Steam (212°F)	A	A	A	B		B	A	A	A	A	A
Stearic Acid	C	B	B	B	A	B		A	A	A	A
Styrene	A	A	A	B	A	D	A	A	A	A	
Succinic Acid	B	B	B					A	A		
Sulfate, Black Liquor	C	B	B	B		B		A	A	A	
Sulfate, Green Liquor	C	B	B	B				A	A	A	
Sulfate, White Liquor	C	B	D	C				A	A	A	
Sulfite Liquors	D	B		D				A	A		
Sulfonic Acid		B		B				A	A		
Sulfur	C	B	A	B		B	A	A	A	A	A
Sulfur Chlorides	D	D	A	B		C		A	A	A	
Sulfur Dioxide, Dry	B	A	B	B	A	A		A	A	A	A
Sulfur Dioxide, Wet		A	B	A	B	B		A	A	A	A
Sulfur Hexafluoride			A	A				A	A	D	
Sulfur, Molten	C	B	A	D	B	B	D	A	A	A	
Sulfur Trioxide	B	B	B		B			D	A	A	
Sulfur Trioxide, Dry	B	B	B	B	B	B		D	A	A	
Sulfuric Acid (0-7%)	D	B	C	C				A	A		
Sulfuric Acid (7-40%)	D	D	B	C				A	A		
Sulfuric Acid (40-75%)	D	D	C	B			B	A	A		
Sulfuric Acid (75-95%)	C	D	B	D				A	A		
Sulfuric Acid (95-100%)	C	C	D	B				A	A		
Sulfurous Acid	D	B	B	D	B	C		A	A	A	A
Synthesis Gas	B	B	B	A				A	A		

A = Excellent

B = Fair

C = Poor

D = Not Recommended

Service Guide

Chemicals	Body/Trim					Seats/Packing					
	Carbon Steel	316 Stainless Steel	Alloy 20	Monel	Hastelloy C	EPDM	PEEK	Graphite	PTFE	Reinforced (PTFE)	UHMWPP
Tall Oil	B	B	B	B	A	D	A	A	A	A	
Tannic Acid	C	B	B	B	B	B	A	A	A	A	A
Tartaric Acid	D	A	A	B	B	B		A	A	A	A
Tetraethyl Lead	C	B	B	A			A	A	A	A	
Thioglycolic Acid		B	B					A	A		
Toluol (Toluene)	A	A	A	A	A	D	A	A	A	A	D
Toluene Diisocyanate		A	A					A	A		
Transformer Oil	A	A	A	A			A	A	A	A	C
Tributyl Phosphate	A	A	A	A		B		A	A	A	
Trichlorethylene	B	B	B	B	A	D		A	A	A	D
Trichloroacetic Acid		D	B	B	A			A	A	C	
Triethanolamine		B	B	B	A	B		A	A	A	C
Triethylamine		B	B		A			A	A		
Triethylene Glycol	C	B	B	B				A	A		
Trisodium Phosphate		B	B		A	B		A	A	A	A
Tung Oil	B	A	A	C	A	D	A	A	A	A	
Turpentine	B	B	B	B	A	D	A	A	A	A	D
Urea	C	B	B	B	A	B	A	A	A	A	A
Uric Acid		A	A		A		A	A	A	A	

Chemicals	Body/Trim					Seats/Packing					
	Carbon Steel	316 Stainless Steel	Alloy 20	Monel	Hastelloy C	EPDM	PEEK	Graphite	PTFE	Reinforced (PTFE)	UHMWPP
Varnish	C	A	A	A	A	D	A	A	A	A	A
Vegetable Oils	B	A	A	B	A	D		A	A	A	A
Vinegar	D	A	A	B	A	A	A	A	A	A	A
Vinyl Acetate		B	B	B	A	A		A	A	A	A
Vinyl Chloride, Dry	A	B	B	B					A	A	
Water, Deionized	D	A	A	A					A	A	
Water, Distilled	D	A	A	A	A	B	A	A	A	A	A
Water, Fresh	C	A	A	A	A	B	A	A	A	A	A
Water, Sea	D	B	B	A					A	A	
Water, Acid Mine	D	B		D	C	A	A	A	A	A	A
Wax Emulsions	A	A	A	A					A	A	
White Water	C	B	B	C					A	A	
Xylene (Xylol), Dry	B	A	A	A	A	D	A	A	A	A	D
Zinc Acetate		B							A	A	
Zinc Chloride	D	D	A	B					A	A	
Zinc Bromide		B	B	B	A	B		A	A	A	
Zinc Hydrosulfite	A	A	A	B	A	A			A	A	
Zinc Sulfate	D	B	A	B	A	A	A	A	A	A	A

A = Excellent

B = Fair

C = Poor

D = Not Recommended

Cam-Tite Ball Valve Operating Instructions

Warning

ITT Industries valves and valve actuators are designed and manufactured using good workmanship and materials, and they meet all applicable industry standards. These valves are available with components of various materials, and they should be used only in services recommended in our product catalog or by a company valve engineer.

Misapplication of the product may result in injuries or property damage. A selection of valve components of the proper materials consistent with the particular performance requirements is important for proper application. Examples of the misapplication or misuse of ITT Industries products include use in an application in which the pressure/temperature rating is exceeded or failure to maintain the valve as recommended.

If the valve exhibits any indication of leakage, do not operate. Isolate the valve and either repair or replace it.

Installation/Operating Instructions

1. This valve can be installed in any position consistent with good piping practice.
2. If this valve has been furnished with a means for relieving body cavity pressure (i.e. a cavity vent), an arrow on the exterior of the valve indicates the direction of pressure tightness. Note: Vented valves are unidirectional.
3. Prior to installation, inspect valve for shipping damage.
4. If this valve is weld end, it may be welded into the pipeline without disassembly provided certain procedures and precautions are taken. The valve should be in the "open" position during welding and should remain open until it cools to ambient temperature. Welding procedures in accordance with Section IX of the ASME Boiler and Pressure Vessel Code should be utilized. In addition, a 350°F Tempilstik (for PTFE and RTFE seats and seals) or a 200°F Tempilstik (for UHMWP seats and seals) must be used to monitor the temperature of the seat/gasket area. Page 12 shows the location on the valve body where the Tempilstik marks should be placed. This is the area in line with the body/cover flange. Welding should be controlled to maintain this area below 350°F or 200°F as noted above. If valves are furnished with other than PTFE, RTFE, or UHMWP seats/seals, contact the factory for recommended welding procedures. (See Page 12 of this brochure for additional details.)
5. Prior to installation or system pressurization, tighten the stem seal nut in accordance with the torques listed in Chart #1. **CAUTION: Do not back off stem seal nut while the valve is pressurized.**
6. Install the operating handle on the valve stem. Insure that the handle is sitting flush with the top of the packing nut and that the handle posts (1/2"-2") are aligned with the groove pin travel stop to assure proper rotation of the handle. Tighten hex jam nut and handle screw (1/2"-2" sizes) or tighten handle screw only (3"-6" sizes).
7. Prior to installation or system pressurization, evenly tighten all cover bolting using the cross-cross method in accordance with the torques listed in Chart #2. **CAUTION: Do not loosen cover bolts while the valve is pressurized.**
8. If necessary, repeat steps 5, 6, and 7 approximately 24 hours after system reaches operating temperature and pressure.
9. Refer to the exploded view on page 41 of this brochure for proper parts identification. Always utilize factory authorized replacement parts.
10. Good operating procedure requires periodic inspection of valves and replacement of necessary parts to ensure proper valve function.
11. NOTE: Valves showing through leakage or high operating torque may be damaged. DO NOT use excessive force or cheater bars to operate valve. Disassemble valve, inspect components, and replace damaged parts.

CAUTION: Before attempting removal/repair, always cycle valve with system pressure isolated to relieve excess pressure which may be trapped in body cavity.

Maintenance Instructions — Cover Gasket Repair

1. Periodically inspect condition of external valve components. Replace all parts showing excessive wear or corrosion.
2. If cover gasket leaks, immediately tighten cover bolting as described under **Installation Instructions, Item 7**. If tightening cover bolting does not stop leak, remove pressure from valve and place valve in open position.
3. Remove cover bolting and lift cover assembly off of valve body.

4. Carefully remove cover gasket from body recess or from cover.
5. Inspect sealing surfaces of both valve body and cover for damage. Replace damaged components as necessary.
6. Replace cover gasket and install cover assembly onto valve body. NOTE: When replacing cover gasket, always place the gasket on the cover and carefully install the cover (with gasket) onto the body to avoid damage to the seal.
7. Install and tighten cover bolting in accordance with **Installation Instructions, Item 7**.

Maintenance Instructions — Stem Seal Replacement

1. **Relieve pressure from valve and place valve in open position.** Remove cover bolting and lift cover assembly off of valve body.
2. Remove hex jam nut on top of handle ($\frac{1}{2}$ "–2" sizes) and remove handle by loosening the handle screw and nut. Remove the packing hex nut, spring washers (2), flat washer ($\frac{1}{2}$ "–2" sizes), rotational stop (3"–6" sizes), gland ring, and grounding spring on stem. Remove stem from bottom of cover and carefully remove upper and lower stem seals from cover counterbore. Refer to Page 41 of this brochure for details of components.
3. Inspect and clean stem and counterbore of cover and replace any components which appear damaged.
4. Replacing stem seals:
 - A. Non-Firesafe Valves: Where lubricant is permitted, apply a light film of DuPont Krytox GPL 206 or other compatible lubricant to stem and (1) stem seal. Install stem seal over threaded end of stem and position it on the stem shoulder. Insert stem through cover from the bottom side.
 - B. Firesafe Valves: Install lower bearing over threaded end of stem and position it on the stem shoulder. Install graphite stem seal over threaded end of stem and position it on the lower bearing. Insert stem through cover from the bottom side.
5. Install the following parts over threaded stem in the order listed:
 - A. Stem seal — Apply a light film of DuPont Krytox GPL 206 or other compatible lubricant, if permitted, to second stem seal.
 - B. Upper bearing — Firesafe valve only.
 - C. Gland Ring
 - D. Flat Washer ($\frac{1}{2}$ "–2" sizes)
 - E. Rotational Stop (3"–6" sizes)
6. Install spring washers and packing hex nut. Hand tighten packing nut to take up the pre-travel caused by seating the stem seals, gland ring and washers.
7. Tighten packing nut in accordance with the torques listed in Chart #1.
8. For $\frac{1}{2}$ "–2" sizes, install handle and tighten hex jam nut and handle screw. For 3"–6" sizes, install handle and tighten handle screw.
9. Clean and inspect cover gasket recess in valve body and cover. Inspect gasket. If damaged, replace cover gasket in accordance with **Cover Gasket Repair Instructions**.
10. Be sure that ground spring is in place over flat of stem and stem shoulder. Spring should bear against bottom of cover and top of ball. Be sure that stem is inserted into the ball and that the cover gasket is properly in place. Align cover holes with tapped body holes.
11. Install and tighten cover bolting in accordance with **Installation Instructions, Item 7**.
12. Cycle valve several times to assure proper operation and break in of seals.
13. If valve has been removed from pipeline for maintenance, reinstall in accordance with **Installation Instructions**.

Maintenance Instructions — Seat Replacement

1. **Relieve pressure from valve and place valve in open position.** Remove cover bolting and lift cover assembly off of valve body.
2. Use a screwdriver or similar tool to lift the ball and seats out of the body. If the ball and seats do not slide easi-

ly out of the valve, check to make sure that the ball is in the open position. The slot for stem engagement should be perpendicular to the pipeline during removal and insertion of the ball. Care should be taken not to damage the surface of the ball while the ball and seats are being removed from the body.

3. Inspect and clean the ball and the body sealing surfaces. Replace any components which are badly scratched or gouged.
4. Apply a light film of lubricant, DuPont Krytox GPL 206 or other compatible lubricant, to the ball and both sides of each of the seat assemblies. Hold the ball and seats such that the I.D.'s of the seats are aligned with the I.D. of the ball port. That is, place the seats on either side of the ball to simulate their position with the valve in the open position. Simultaneously slide the two seat assemblies and the ball into the valve body. Force is not necessary to properly position the components in the valve. Should the ball and seats not slide easily into place, check to make sure that the ball is being inserted while in the open position.
5. Clean and inspect cover gasket recess in valve body and cover. Inspect gasket. If damaged, replace cover gasket in accordance with **Cover Gasket Repair Instructions**.
6. Be sure that ground spring is in place over flat of stem and stem shoulder. Spring should bear against bottom of cover and top of ball. Be sure that stem is inserted into the ball and that the cover gasket is properly in place. Align cover holes with tapped body holes.
7. Install and tighten cover bolting in accordance with **Installation Instructions, Item 7**.
8. Cycle valve several times to assure proper operation and break in of seats.
9. If valve has been removed from pipeline for maintenance, reinstall in accordance with **Installation Instructions**.

Chart #1 — Stem Seal Packing Nut Torques

Caution: Tighten Cam-Tite stem seals by turning the adjusting nut in a clockwise direction. Do not back off packing nut while valve is under pressure or in the closed position.

VALVE SIZE	TORQUE (ft-lb)
1/2"-1"	9
1 1/2"	10
2"	16
3"	40
4"	40
6"	105

Note: The above packing nut torques apply to all non-firesafe stem seals. For firesafe graphite stem seals, the correct method of adjustment is to tighten the packing nut until the belleville spring washers are flat.

Chart #2 — Cover Bolt Torques

Caution: The torques below apply to coarse thread bolts when a lubricant having a coefficient of friction between 0.05 and 0.06 is utilized on the threads and under the head of the bolt. If tightening of the cover is attempted without the use of a lubricant, consult the factory for recommended procedures.

VALVE SIZE	UHMWP, PTFE AND REINFORCED PTFE GASKET TORQUE BY PRESSURE CLASS (ft-lb)		
	150	300	600
1/2"-1"	10	10	20
1 1/2"	15	15	30
2"	25	25	50
3"	25	25	50
4"	33	33	78
6"	50	75	—

VALVE SIZE	GRAPHITE GASKET TORQUE BY PRESSURE CLASS (ft-lb)		
	150	300	600
1/2"-1"	23	23	23
1 1/2"	29	29	29
2"	46	46	46
3"	58	58	58
4"	60	60	60
6"	145	200	—

Exploded View 1/2" - 6"

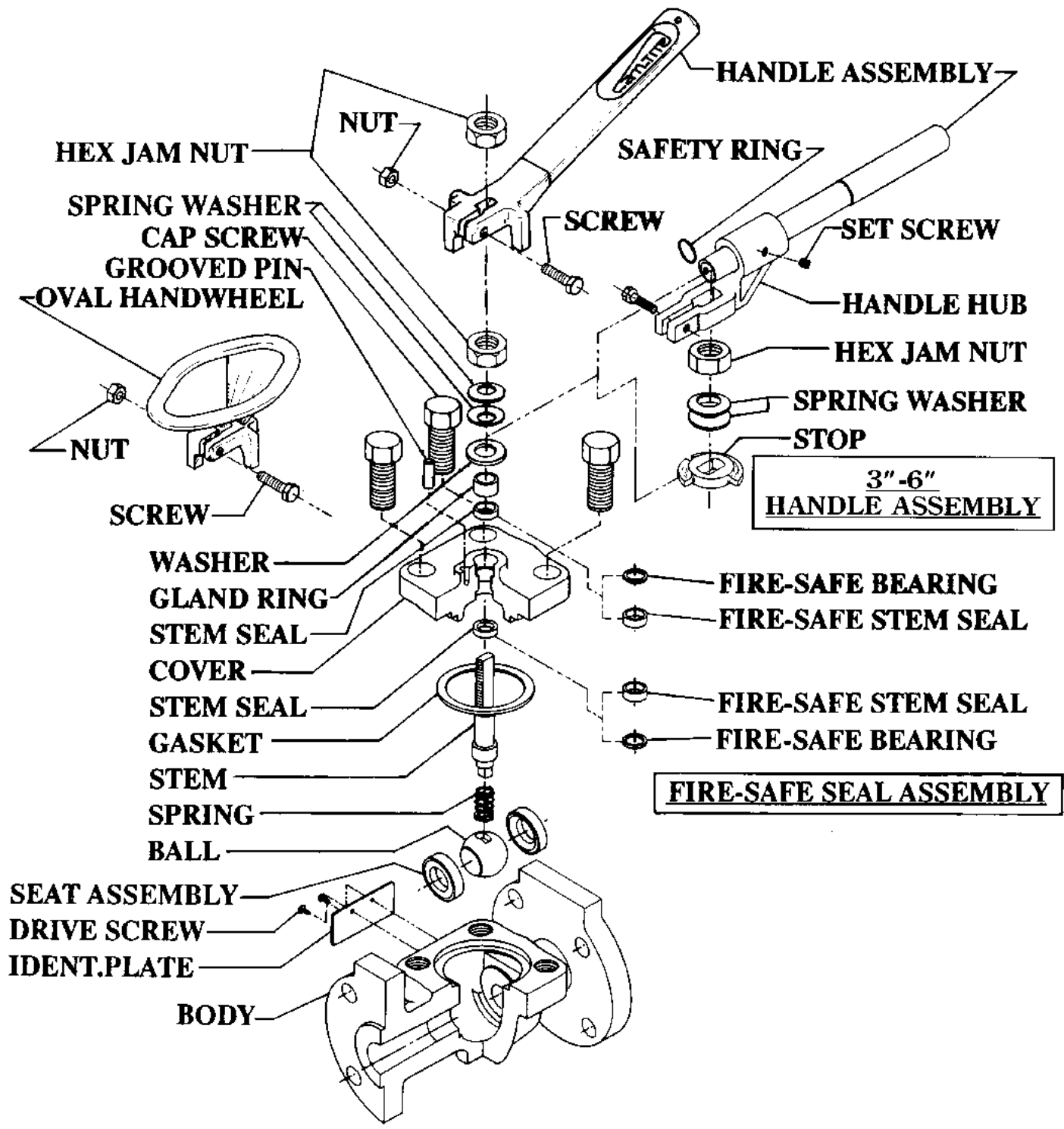

STANDARD BALL VALVE ASSEMBLY

Compliance With National Standards

Cam-Tite Ball Valves are designed to the following ANSI specifications:

ANSI B2.1	Pipe Threads
ANSI B16.5	Flanges and Flanged Fittings
ANSI B16.11	Socketweld and Threaded Fittings
ANSI B16.25	Buttweld Ends
ANSI B16.34*	Flanged, Threaded and Weld End Valves
ANSI B31.1	Power Piping
ANSI B31.3	Chemical Plant and Petroleum Refinery Piping

*Compliance to ANSI B16.34 is dependent on the materials of construction selected and the testing specified for each application. Consult the factory for further details.

All standard Cam-Tite Ball Valves are tested and tagged in accordance with the following specifications:

MSS-SP-25	Marking System for Valves
MSS-SP-72	Ball Valves for General Service

In addition, Cam-Tite Ball Valves can be furnished in accordance with the special requirements of the following specifications:

ANSI B31.3	Category M Service
API 598	Valve Inspection and Testing
API 607	Firetesting for Soft Seated Quarter Turn Valves
Chlorine Institute Pamphlet 6	Ball Valves for Dry Chlorine Service
NACE Standard MR01-75	Materials for Oilfield Equipment

Material Standards

All Cam-Tite body and bonnet castings are in accordance with one of the following standards:

Carbon Steel	ASTM A216 GR WCB
Carbon Steel (Low Temperature)	ASTM A352 GR LCB
Carbon Steel (Low Temperature)	ASTM A352 GR LC-1
316 Stainless Steel	ASTM A351 GR CF8M
316 L Stainless Steel	ASTM A351 GR CF3M
Alloy 20	ASTM A351 GR CN7M
Monel	ASTM A494 GR M-35-1
Hastelloy C	ASTM A494 GRs CW-6M or CW-2M
Inconel	ASTM A494 GR CY-40
Nickel	ASTM A494 GR CZ-100
Titanium	ASTM B367 GR C3

All standard Cam-Tite Ball Valve cover bolting is in accordance with the following standards:

Carbon Steel	ASTM A193 GR B7
Stainless Steel	ASTM A193 GR B8

Certified Material Test Reports (CMTRs) can be supplied on the above materials. Contact Engineered Valves for additional information on materials not listed.

Ordering Information

How to Order Cam-Tite® Ball Valves

The Cam-Tite Ball Valve is designated by a series of configuration numbers that define the valve size (block A); base body construction (blocks B1–B4); cover type (block C); ball/stem material (block D1); seat material (block S1); stem seal / gasket materials (blocks S2-S3); actuation (blocks N1-N6); and additional options (blocks D3-L). By selecting the proper code for each of the required blocks, the configuration number can be specified. For a complete listing of the available codes, see pages 44 and 45. A blank Production Specification Worksheet can be found on page 48 of the catalog.

BLOCK	FEATURES	Example 1	Example 2
A	Size	2	1
B1	Body	3010	3215
B2	Buttweld Schedule		
B4	Drain Port		
C	Cover	1	1
D1	Ball / Stem Material	T1	T3
S1	Seat Material	ST1	ST2
S2	Stem Seal / Gasket Material	SL1	SL2
S3	Gasket material / Bellows Only		
N1	Actuation		
N2	Actuator Mode		
N3	Actuator Springs		
N4	Fail Position		
N5	Solenoid Valve		
N6	Limit Switches		
D3	Exterior Trim		
D2	Extended Stem		
D4	Optional Fasteners		
E	Handle Options		HD3
F	Locking Device		LDS
K	Optional Preparations		
L	Nace Service		

Example 1: 2-3010-1-T1-ST1-SL1

2" ANSI Class 150# Flanged Carbon Steel Ball Valve with Standard Cover, 316 Stainless Steel Trim, PTFE Seats and Seals, and Hand Lever Operator.

Example 2: 3215-1-T3-ST2-SL2-HD3-LDS

1" ANSI Class 150-300# Socketweld End Alloy 20 Ball Valve with Standard Cover, Alloy 20 Trim, RTFE Seats and Seals, and Oval Handwheel Operator with Stainless Steel Locking Device.

Figure Numbers - Bodies, Covers & Trim

Size Range

Cam-Tite Ball Valves (Block A)

Code	Valve Size
0.5	1/2"
0.75	3/4"
1	1"
1.5	1 1/2"
2	2"
3	3"
4	4"
6	6"

Flanged Ends

Cam-Tite Ball Valves (Block B1)

Code	Body Material
150#	
3010	Carbon Steel WCB
3110	Carbon Steel LCB
3810	Carbon Steel LC-1
3011	316L Stainless Steel
3211	Alloy 20
3311	Monel
3411	Hastelloy C
3511	Nickel
3611	Titanium
3711	Inconel

300#

3018	Carbon Steel WCB
3118	Carbon Steel LCB
3818	Carbon Steel LC-1
3019	316L Stainless Steel
3219	Alloy 20
3319	Monel
3419	Hastelloy C
3519	Nickel
3619	Titanium
3719	Inconel

600#

3026	Carbon Steel WCB
3126	Carbon Steel LCB
3826	Carbon Steel LC-1
3027	316L Stainless Steel
3227	Alloy 20
3327	Monel
3427	Hastelloy C
3527	Nickel
3627	Titanium
3727	Inconel

Buttweld Ends

Cam-Tite Ball Valves (Block B1)

Code	Body Material
150#	
3012	Carbon Steel WCB
3112	Carbon Steel LCB
3812	Carbon Steel LC-1
3113	316L Stainless Steel
3213	Alloy 20
3313	Monel
3413	Hastelloy C
3513	Nickel
3613	Titanium
3713	Inconel

Buttweld Ends

Cam-Tite Ball Valves (Block B1)

Code	Body Material
300#	
3020	Carbon Steel WCB
3120	Carbon Steel LCB
3820	Carbon Steel LC-1
3121	316L Stainless Steel
3221	Alloy 20
3321	Monel
3421	Hastelloy C
3521	Nickel
3621	Titanium
3721	Inconel

600#

3028	Carbon Steel WCB
3128	Carbon Steel LCB
3828	Carbon Steel LC-1
3129	316L Stainless Steel
3229	Alloy 20
3329	Monel
3429	Hastelloy C
3529	Nickel
3629	Titanium
3729	Inconel

Socketweld Ends

Cam-Tite Ball Valves (Block B1)

Code	Body Material
150#-300#	
3014	Carbon Steel WCB
3114	Carbon Steel LCB
3814	Carbon Steel LC-1
3115	316L Stainless Steel
3215	Alloy 20
3315	Monel
3415	Hastelloy C
3515	Nickel
3615	Titanium
3715	Inconel

600#

3022	Carbon Steel WCB
3122	Carbon Steel LCB
3822	Carbon Steel LC-1
3123	316L Stainless Steel
3223	Alloy 20
3323	Monel
3423	Hastelloy C
3523	Nickel
3623	Titanium
3723	Inconel

Threaded Ends

Cam-Tite Ball Valves (Block B1)

Code	Body Material
150#-300#	
3016	Carbon Steel WCB
3116	Carbon Steel LCB
3816	Carbon Steel LC-1
3117	316L Stainless Steel
3217	Alloy 20
3317	Monel
3417	Hastelloy C
3517	Nickel
3617	Titanium
3717	Inconel

Threaded Ends

Cam-Tite Ball Valves (Block B1)

Code	Body Material
600#	
3024	Carbon Steel WCB
3124	Carbon Steel LCB
3824	Carbon Steel LC-1
3125	316L Stainless Steel
3225	Alloy 20
3325	Monel
3425	Hastelloy C
3525	Nickel
3625	Titanium
3725	Inconel

Buttweld Schedule (Block B2)

Code	End Preparation
SCH10	Schedule 10
SCH40	Schedule 40
SCH80	Schedule 80

Drain Port (Block B4)

Code	Drain Port
D	Body Port with Plug

Cover (Block C)

Code	Cover
1	Standard
2	Extended
3	Severe Service
4	Severe Service with Lantern Ring
5	Bellows Seal / Manual
6	Bellows Seal / Actuated
7	Fire Safe Bellows Seal / Manual
8	Standard with Internals Cage
9	Extended with Internals Cage
10	Severe Service with Internals Cage
11	Severe Service with Lantern Ring and Internals Cage
12	Body Only

Ball / Stem (Block D1)

Code	Ball / Stem Material
T1	316SS / 316SS
T2	Monel / Monel
T3	Alloy 20 / Alloy 20
T4	Hastelloy C / Hastelloy C
T5	Hastelloy C / Monel
T6	Monel / Hastelloy C
T7	316SS / Hastelloy C
T8	Inconel 625 / Inconel 625
T9	Ceramic / 316SS
T10	Ceramic / Monel
T11	Ceramic / Alloy 20
T12	Ceramic / Hastelloy C
T13	Nickel / Nickel
T14	Titanium / Titanium
T15	Tantalum / Hastelloy C
T16	304SS / 304SS
T17	Alloy 20 / Inconel 718
T18	Tantalum / Nickel
T19	316SS/17-4 PhSS

Figure Numbers - Actuators, Actuator Accessories & Bonnet Options

Seat Material (Block S1)

Code	Seat Material
ST1	PTFE
ST2	RTFE
ST3	Firesafe RTFE
ST4	Firesafe PTFE
ST5	UHMW Polyethylene
ST6	G2000 PEEK
ST7	G3000 PEEK
ST9	PTFE/Carbon Filled
ST10	Firesafe Design PTFE/ Carbon Filled

Stem Seal /

Gasket Material (Block S2)

Code	Stem Seal / Gasket Material
SL1	PTFE/PTFE
SL2	RTFE/RTFE
SL3	UHMWP / UHMWP
SL4	Graphite / Graphite
SL5	Graphite / PTFE
SLT6	Graphite / RTFE
SL7	Graphite / G2000 PEEK
SL8	Graphite / G3000 PEEK

Gasket Material /

Bellows Only (Block S3)

Code	Gasket Material
G1	PTFE
G2	RTFE
G3	UHMWP
G4	Graphite
G5	G2000 PEEK
G6	G3000 PEEK

Actuator (Block N1)

Code	Actuator Model
H15	H15 Compact Actuator
H20	H20 Compact Actuator
H25	H25 Compact Actuator
H30	H30 Compact Actuator
H35	H35 Compact Actuator
H45	H45 Compact Actuator
H60	H60 Compact Actuator
H75	H75 Compact Actuator
G80	Mastergear Model 980
G81	Mastergear Model 981
G84	Mastergear Model 984
G87	Mastergear Model 987

Compact Actuator

Mode (Block N2)

Code	Actuator Model
DA	Double Acting
SR	Spring Return

Compact Actuator

Mode (Block N3)

Code	Actuator Springs
1A	1A
1B	1B
2	2
2A	2A
2B	2B
2C	2C
3	3

Compact Actuator

Failure Position (Block N4)

Code	Failure Position
FO	Fail Open
FC	Fail Closed

Solenoid Valve (Block N5)

Code	Description
SV1	Asco 8320G184
SV2	Asco EF8320G184
SV3	Asco 8345G1
SV4	Asco EF8345G1

Actuator

Limit Switches (Block N6)

Code	Description
LS1	Westlock 1065
LS2	Westlock 1040
LS3	Westlock 2004BY
LS4	Westlock 2007XBY
LS5	Posiflex F30A-A-A
LS7	Posiflex F30A-C-A
LS9	Westlock 3030BY
LS10	Westlock 9479BY

Exterior Trim (Block D3)

Code	Trim Material
ET1	Stainless Steel Gland, Bellevilles, Washers and Nuts
ET2	Stainless Steel Gland, Washers and Nuts / Inconel Bellevilles
ET3	Inconel Gland, Washers, Nuts and Bellevilles
ET4	Hastelloy Gland, Washers and Nuts / Inconel Bellevilles

Extended Stem (Block D3)

Code	Extension Type
EXTSP	Stem Extension w/out Bracket
EXTSPBK	Stem Extension with Bracket

Optional Fasteners (Block D4)

Code	Material
BOLTING	
B1	A193 GR B7
B2	A320 GR L7

Optional Fasteners (Block D4)

Code	Material
BOLTING (cont.)	
B3	A193 GR B8
B4	Inconel
B5	Hastelloy
B6	Alloy 20
B7	A193 GR B7/PTFE Coated
B8	Monel
B9	A193 GR B7M

STUDS / NUTS

SN1	A193 GR B7 / A194 GR 2H
SN2	A320 GR L7 / A194 GR L7
SN3	A193 GR B8 / A194 GR B8
SN4	Inconel / Inconel
SN5	Hastelloy / Hastelloy
SN6	Alloy 20 / Alloy 20
SN7	A193 GR B7/PTFE Coated
SN8	Monel / Monel

Handle Options (Block E)

Code	Material
HANDLE	
HD1	Stainless Steel

OVAL HANDWHEEL

HD2	Carbon Steel
HD3	Stainless Steel

CHAINWHEEL

HD5	Carbon Steel Horizontal Line
HD6	Carbon Steel Vertical Line
HD7	Stainless Steel Horiz. Line
HD8	Stainless Steel Vertical Line

Locking Device (Block F)

Code	Material
LDS	Stainless Steel

Optional Preparation (Block K)

Code	Preparation
CLV	Chlorine / Vented Body
HF	Hydrofluoric Acid
HFV	HF Acid / Vented Body
OX	Oxygen
PHO	Phosgene
PHOV	Phosgene / Vented Body
TOB	Tobacco Service (No PTFE)
TOBV	Tobacco Service / Vented
V	Vented Body
NL	No Lubricant
VNL	Vented Body / No Lubricant
VB	Vented Ball
CLN	Cleaned and bagged
CLNV	Vented body/cleaned and bagged

Nace Service (Block L)

Code	Nace Service
NACE1	Nace 1 Service
NACE2	Nace 2 Service
NACE3	Nace 3 Service

Metric Conversion Table

Inches	Millimeters
0	0.0000
1/128	0.1984
1/64	0.3969
3/128	0.5953
1/32	0.7937
5/128	0.9921
3/64	1.1906
7/128	1.3890

Convert 3.7643 meters to feet, inches and fractions
 3.7643 meters
 $\frac{3.6556}{108.70} \text{ mm} = 12 \text{ ft.}$
 $\frac{107.95}{.75} = 4\frac{1}{4} \text{ in.}$
 $\frac{.75}{.75} = \frac{1}{32}''$
 3.7643 meters = 12'-4-9/32"

Convert 15'-6-7/16" to meters
 15' = 4.5720 meters
 $6\text{-}7/16'' = .163513 \text{ meters}$
 15'-6-7/16" = 4.735513 meters

INCHES AND FRACTIONS — MILLIMETERS											
Inches	Millimeters	Inches	Millimeters	Inches	Millimeters	Inches	Millimeters	Inches	Millimeters	Inches	Millimeters
1/16	1.5875	2-1/16	52.3876	4-1/16	103.188	6-1/16	153.988	8-1/16	204.788	10-1/16	255.588
1/8	3.1750	2-1/8	53.9751	4-1/8	104.775	6-1/8	155.575	8-1/8	206.375	10-1/8	257.176
3/16	4.7625	2-3/16	55.5626	4-3/16	106.363	6-3/16	157.163	8-3/16	207.963	10-3/16	258.763
1/4	6.3500	2-1/4	57.1501	4-1/4	107.950	6-1/4	158.750	8-1/4	209.550	10-1/4	260.351
5/16	7.9375	2-5/16	58.7376	4-5/16	109.538	6-5/16	160.338	8-5/16	211.138	10-5/16	261.938
3/8	9.5250	2-3/8	60.3251	4-3/8	111.125	6-3/8	161.925	8-3/8	212.725	10-3/8	263.526
7/16	11.1125	2-7/16	61.9126	4-7/16	112.713	6-7/16	163.513	8-7/16	214.313	10-7/16	265.113
1/2	12.7000	2-1/2	63.5001	4-1/2	114.300	6-1/2	165.100	8-1/2	215.900	10-1/2	266.701
9/16	14.2875	2-9/16	65.0876	4-9/16	115.888	6-9/16	166.688	8-9/16	217.488	10-9/16	268.288
5/8	15.8750	2-5/8	66.6751	4-5/8	117.475	6-5/8	168.275	8-5/8	219.075	10-5/8	269.876
11/16	17.4625	2-11/16	68.2626	4-11/16	119.063	6-11/16	169.863	8-11/16	220.663	10-11/16	271.463
3/4	19.0500	2-3/4	69.8501	4-3/4	120.650	6-3/4	171.450	8-3/4	222.250	10-3/4	273.051
13/16	20.6375	2-13/16	71.4376	4-13/16	122.238	6-13/16	173.038	8-13/16	223.838	10-13/16	274.638
7/8	22.2250	2-7/8	73.0251	4-7/8	123.825	6-7/8	174.625	8-7/8	225.425	10-7/8	276.226
15/16	23.8125	2-15/16	74.6126	4-15/16	125.413	6-15/16	176.213	8-15/16	227.013	10-15/16	277.813
1	25.4001	3	76.2002	5	127.00	7	177.800	9	228.600	11	279.401
1-1/16	26.9876	3-1/16	77.7877	5-1/16	128.588	7-1/16	179.388	9-1/16	230.188	11-1/16	280.988
1-1/8	28.5751	3-1/8	79.3752	5-1/8	130.175	7-1/8	180.975	9-1/8	231.775	11-1/8	282.576
1-3/16	30.1626	3-3/16	80.9627	5-3/16	131.763	7-3/16	182.563	9-3/16	233.363	11-3/16	284.163
1-1/4	31.7501	3-1/4	82.5502	5-1/4	133.350	7-1/4	184.150	9-1/4	234.950	11-1/4	285.751
1-5/16	33.3376	3-5/16	84.1377	5-5/16	134.938	7-5/16	184.738	9-5/16	236.538	11-5/16	287.338
1-3/8	34.9251	3-3/8	85.7252	5-3/8	136.525	7-3/8	187.325	9-3/8	238.125	11-3/8	288.926
1-7/16	36.5126	3-7/16	87.3127	5-7/16	138.113	7-7/16	188.913	9-7/16	239.713	11-7/16	290.513
1-1/2	38.1001	3-1/2	88.9002	5-1/2	139.700	7-1/2	190.500	9-1/2	241.300	11-1/2	292.101
1-9/16	39.6876	3-9/16	90.4877	5-9/16	141.288	7-9/16	192.088	9-9/16	242.888	11-9/16	293.688
1-5/8	41.2751	3-5/8	92.0752	5-5/8	142.875	7-5/8	193.675	9-5/8	244.475	11-5/8	295.276
1-11/16	42.8626	3-11/16	93.6627	5-11/16	144.463	7-11/16	195.263	9-11/16	246.063	11-11/16	296.863
1-3/4	44.4501	3-3/4	95.2502	5-3/4	146.051	7-3/4	196.850	9-3/4	247.650	11-3/4	298.451
1-13/16	46.0376	3-13/16	96.8377	5-13/16	147.638	7-13/16	198.438	9-13/16	249.238	11-13/16	300.038
1-7/8	47.6251	3-7/8	98.4252	5-7/8	149.225	7-7/8	200.025	9-7/8	250.825	11-7/8	301.626
1-15/16	49.2126	3-15/16	100.013	5-15/16	150.813	7-15/16	201.613	9-15/16	252.413	11-15/16	303.213
2	50.8001	4	101.600	6	152.400	8	203.200	10	254.001	12	304.801

Units to be converted ▼	TORQUE CONVERSION FACTORS								
	AMERICAN STD.			METRIC			INTERNATIONAL SYSTEM — S.I.		
	oz-in	lb-in	lb-ft	g-cm	kg-cm	kg-m	mN-m	cN-m	N-m
1 oz - in =	1	0.0625	0.0005	72	0.072	0.0007	7.062	0.706	0.007
1 lb - in =	16	1	0.083	1152.1	1.152	0.0115	113	11.3	0.113
1 lbf - ft =	192	12	1	13 826	13.83	0.138	1356	135.6	1.356
1 g - cm =	0.014	0.0009	0.000 07	1	0.001	0.0001	0.098	0.01	0.0001
1 kg - cm =	13.89	0.868	0.072	1000	1	0.01	98.07	9.807	0.098
1 kg - m =	1389	86.8	7.233	100000	100	1	9807	980.7	9.807
1 mN - m =	0.142	0.009	0.0007	10.2	0.01	0.0001	1	0.1	0.001
1 cN - m =	14.16	0.088	0.007	102	0.102	0.001	10	1	0.01
1 N - m =	141.6	8.851	0.738	10 197	10.20	0.102	1000	100	1

Conversion Factors

Multiply	by	To Obtain	Multiply	by	To Obtain
Bar	14.5	Pounds/square inch	Inches of Hg at 62°F	13.6114	Inches of water at 62°F
Centimeters	0.3937	Inches		7.85872	Ounces/square inch
	0.032808	Feet	Inches of water at 62°F	0.00245	Atmospheres
	0.01	Meters		25.37	Kilograms/square meter
	10	Millimeters	Kilopascals (kPa)	0.1450377	lb./in ² (Psi)
Cubic feet of water	62.4266	Pounds at 39.2°F	Kilogram/sq meter	9.678 X 10 ⁻⁵	Atmospheres
	62.3554	Pounds at 62°F		0.003285	Feet of water at 62°F
Cubic meters/hour	4.40	Gallons (US)/minute		0.002896	Inches of Hg at 32°F
Degrees F (less 32)	0.5556	Degrees C		0.2048	Pounds/square foot
Degrees F	1 (plus 460)	Degrees F above absolute 0		0.001422	Pounds/square inch
Degrees C	1.8 (plus 32)	Degrees F		0.007356	Centimeters of Hg at 32°F
	1 (plus 273)	Degrees C above absolute 0	Liters	1000	Cubic centimeters
Feet of water at 62	0.029465	Atmospheres		0.03531	Cubic feet
	0.88162	Inches of Hg at 32°F		61.02	Cubic inches
	62.3554	Pounds/square foot		0.001	Cubic meters
	304.44	Kilogram/sq meter		0.001308	Cubic yards
Gallons (US)	3785	Cubic centimeters		0.2642	Gallons (US)
	0.13368	Cubic feet		0.22	Gallons (Imp)
	231	Cubic inches		2.113	Pints (liq. US)
	0.003785	Cubic meters		1.057	Quarts (liq. US)
	0.004951	Cubic yards		8.107 X 10 ⁻⁷	Acre Feet
	3.785	Liters		2.2018	Pounds of water at 62°F
	8	Pints (liq. US)	Liters/minute	0.0005886	Cubic feet/second
	4	Quarts (liq. US)		0.004403	Gallons (US)/second
	0.83267	Gallons (Imperial)		0.26418	Gallons (US)/minute
	3.069 X 10 ⁻⁶	Acre feet	Meters	100	Centimeters
Gallons (US) of water at 62°F	8.3357	Pounds of water	Microns Hg	0.001	Torr
Gallons (US)/minute	0.002228	Cubic feet/second	Millimeters	0.1	Centimeters
	0.13368	Cubic feet/minute		0.03937	Inches
	8.0208	Cubic feet/hour		39.37	Mils
	0.06309	Liters/second		1000	Microns
	3.78533	Liters/minute	Pounds of water at 62°F	0.01604	Cubic feet
	0.0044192	Acre feet/24 hours		27.72	Cubic inches
	0.227	Cubic meters/hour		0.120	Gallons (US)
Inches	2.54	Centimeters	Pounds of water/min. at 62°F	0.0002673	Cubic feet/second
	0.08333	Feet	Pounds/square inch	6.894759	Kilopascals (kPa)
	1000	Mils		0.068044	ATmospheres
	12	Lines		2.30934	Feet of water at 62°F
	72	Points		2.0360	Inches of Hg at 32°F
	25.4	Millimeters (mm)		703.067	Kilograms/square meter
Inches of Hg at 32°F	0.3342	Atmospheres		27.912	Inches of water at 62°F
	345.3	Kilograms/square meter		0.06894757	Bar
	70.73	Pounds/square foot		52.16	Millimeters Hg
	0.49117	Pounds/square inch	Torr	.0013158	ATMOS
	1.1343	Feet of water at 62°F		133.32	N/M ²
				.99999986	MMHG

Product Specification Worksheet

Engineered Valves
 33 Centerville Road
 Lancaster, PA 17543
 Phone: 717-509-2200
 Fax: 717-509-2336

Date: _____

BLOCK	FEATURES	Item 1	Item 2	Item 3	Item 4	Item 5
	Quantity					
A	Size					
B1	Body					
B2	Buttweld Schedule					
B4	Drain Port					
C	Cover					
D1	Ball / Stem Material					
S1	Seat Material					
S2	Stem Seal / Gasket Material					
S3	Gasket Material / Bellows Only					
N1	Actuation					
N2	Actuator Mode					
N3	Actuator Springs					
N4	Fail Position					
N5	Solenoid Valve					
N6	Limit Switches					
D3	Exterior Trim					
D2	Extended Stem					
D4	Optional Fasteners					
E	Handle Options					
F	Locking Device					
K	Optional Preparations					
L	Nace Service					

Use the above worksheet to specify the proper Cam-Tite Ball Valve configuration number and the quantity of valves required. Contact Engineered Valves or your local Cam-Tite distributor for pricing, delivery, or additional technical information.

CONDITIONS AND TERMS OF SALE OF ITT INDUSTRIES (hereinafter referred to as Seller)

1. **CONTROLLING PROVISIONS:** These terms and conditions shall control with respect to any purchase order or sale of Seller's products. No waiver, alteration or modification of these terms and conditions whether on Buyer's purchase order or otherwise shall be valid unless the waiver, alteration or modification is specifically accepted in writing and signed by an authorized representative of Seller.
2. **DELIVERY:** Seller will make every effort to complete delivery of products as indicated on Seller's acceptance of an order, but Seller assumes no responsibility or liability, and will accept no backcharge for loss or damage due to delay or inability to deliver caused by acts of God, war, labor difficulties, accident, delays of carriers, by contractors or suppliers, inability to obtain materials, shortages of fuel and energy or any other causes of any kinds whatever beyond the control of Seller. Seller may terminate any contract of sale of its products without liability of any nature, by written notice to Buyer, in the event that the delay in delivery or performance resulting from any of the aforesaid causes shall continue for a period of sixty (60) days. Under no circumstances shall Seller be liable for any special or consequential damages or for loss, damage or expense (whether or not based on negligence) directly or indirectly arising from delays or failure to give notice of delay.
3. **WARRANTY:** Seller warrants for one year from the date of shipment Seller's manufactured products to the extent that Seller will replace those having defects in material or workmanship when used for the purpose and in the manner which Seller recommends. If Seller's examination shall disclose to its satisfaction that the products are defective, and an adjustment is required, the amount of such adjustment shall not exceed the net sales price of the defective products only and no allowance will be made for labor or expense of repairing or replacing defective products or workmanship or damage resulting from the same. Seller warrants the products which it sells of other manufacturers to the extent of the warranties of their respective makers. Where engineering design or fabrication work is supplied, Buyer's acceptance of Seller's design or of delivery of work shall relieve Seller of all further obligation, other than as expressed in Seller's product warranty. **THIS IS SELLER'S SOLE WARRANTY. SELLER MAKES NO OTHER WARRANTY OF ANY KIND, EXPRESSED OR IMPLIED. AND ALL IMPLIED WARRANTIES OF MERCHANTABILITY AND FITNESS FOR A PARTICULAR PURPOSE WHICH EXCEED SELLER'S AFORESTATED OBLIGATION ARE HEREBY DISCLAIMED BY SELLER AND EXCLUDED FROM THIS WARRANTY.** Seller neither assumes, nor authorizes any person to assume for it, any other obligation in connection with the sale of its engineering designs or products. This warranty shall not apply to any products or parts of products which (a) have been repaired or altered outside of Seller's factory, in any manner; or (b) have been subjected to misuse, negligence or accidents; or (c) have been used in a manner contrary to Seller's instructions or recommendations. Seller shall not be responsible for design errors due to inaccurate or incomplete information supplied by Buyer or its representatives.
4. **SELLER'S LIABILITY:** Seller will not be liable for any loss, damage, cost of repairs, incidental or consequential damages of any kind, whether based upon warranty (except for the obligation accepted by Seller under "Warranty" above), contract or negligence, arising in connection with the design, manufacture, sale, use or repair of the products or of the engineering designs supplied to Buyer.
5. **RETURNS:** Seller cannot accept return of any products unless its written permission has been first obtained, in which case same will be credited subject to the following: (a) All material returned must, on its arrival at Seller's plant, be found to be in first-class condition; if not, cost of putting in saleable condition will be deducted from credit memoranda; (b) A handling charge will be made from all credit memoranda issued for material returned; (c) Transportation charges, if not prepaid, will be deducted from credit memoranda.
6. **SHIPMENTS:** All products sent out will be carefully examined, counted and packed. The cost of any special packing or special handling caused by Buyer's requirements or requests shall be added to the amount of the order. No claim for shortages will be allowed unless made in writing within ten (10) days of receipt of a shipment. Claims for products or lost in transit should be made on the carrier, as Seller's responsibility ceases, and title passes, on delivery to the carrier.
7. **SPECIAL PRODUCTS:** Orders covering special or non-standard products are not subject to cancellation except on such terms as Seller may specify on application.
8. **PRICES AND DESIGNS:** Prices and designs are subject to change without notice. All prices are F.O.B. Point of Shipment, unless otherwise stated.
9. **TAXES:** The amount of any sales, excise or other taxes, if any, applicable to the products covered by this order, shall be added to the purchase price and shall be paid by Buyer unless Buyer provides Seller with an exemption certificate acceptable to the taxing authorities.
10. **MINIMUM INVOICE:** \$200.00 plus transportation on complete valve assemblies. \$100.00 plus transportation on replacement parts.
11. **TERMS:** Cash, net 30 days unless otherwise specified.

Warning

ITT Industries Valves and Valve Actuators are designed and manufactured using good workmanship and materials, and they meet all applicable industry standards. These valves are available with components of various materials, and they should be used only in services recommended in this product catalog or by a company valve engineer.

ITT Industries is anxious to avoid injuries and property damage which could result from a misapplication of the product. A selection of a valve of the proper material consistent with the particular performance requirement, is important for safe use.

Examples of the misapplication or misuse of a CAM-TITE® Valve include use in an application in which the pressure/temperature rating is exceeded and failure to maintain valves as recommended. If a valve appears to be leaking, do not operate. Remove valve from service, repair, or replace.

Cam-Tite is a registered trademark of ITT Industries, Engineered Valves.

Krytox® is a registered trademark of E. I. DuPont.

ENGINEERED VALVES

For additional information on ENGINEERED VALVES products as referenced, call 1-800-2ITT-FTC, (1-800-248-8382) or contact the nearest regional office listed below.

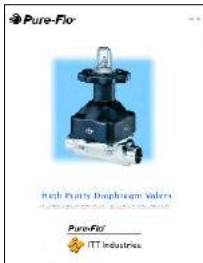

PURE-FLO®
High Purity
Diaphragm Valves



RICHTER®
Lined Valves For
Corrosive Applications

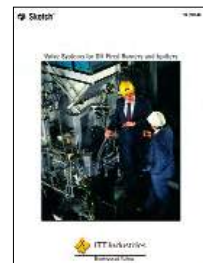

SKOTCH®
Burner Shut-Off Valves

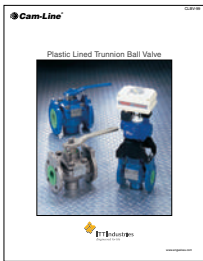

CAM-LINE®
Lined Ball Valves

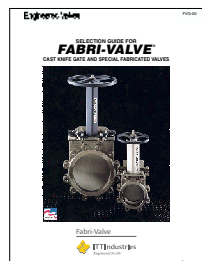

FABRI-VALVE®
Knife Gate and Special
Fabricated Valves

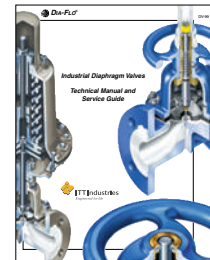

DIA-FLO®
Industrial
Diaphragm Valves

Industrial Group

For more information write to:

Engineered Valves Headquarters

33 Centerville Road, P.O. Box 6164

Lancaster, PA 17603-2064 USA

or call: (800) 366-1111

(717) 509-2200

Fax: (717) 509-2336

Website: www.engvalves.com

E-mail: engvalves.custserv@itt.com

REGIONAL OFFICES

ATLANTIC – USA

Phone 800-231-0328

Phone (717) 509-2200

Fax 800-231-0330

Fax (717) 509-2336

CENTRAL – USA

Phone 800-366-4770

Phone (717) 509-2200

Fax 800-231-0330

Fax (717) 509-2336

PACIFIC – USA

725 E. Cochran Street, Unit E

Simi Valley, CA 93065

Phone 800-926-8884

Phone (805) 520-7200

Fax (805) 520-7205

SOUTH AMERICA

Av. 11 de Septiembre #1363

Of. 1403 Providencia

Santiago - Chile

Phone +56-2-264-9491

(9637)

Fax +56-2-236-1799

MEXICO

Insurgentes Sur No.600-4°P

Col. Del Valle

C.P. 03100 Mexico D.F.

Phone +52-5-669-5002

Fax +52-5-669-5289

PUERTO RICO

P.O. Box 1225

Hato Rey, PR 00919

Phone/Fax (787) 703-0402

EUROPE

Richards Street

Kirkham, Lancashire

PR4 2HU, England

Phone +44-1772-682696

Fax +44-1772-686006

HONG KONG

Units 1903-04 CRE Centre

928-930 Cheung Sha Wah Road

Kowloon, Hong Kong

Phone +852-2741-6302

Fax +852-2741-6605



ITT Industries

Engineered for life